

# Physical Function Testing Apparatus for Monkey

Biomedical Engineering Design 301

Team Members: Naren Chaudhry (BSAC), Ben Myers (BWIG/BPAG), Ben  
Ratliff (Team Leader), Eli Stanek (Communicator)

Client: Dr. Ricki Colman

Advisor: Dr. Beth Meyerand

## **Abstract**

Rhesus monkeys have long been used as models for scientific research for due to their similar anatomy to humans [1]. One similarity that has been used for research is the motor function of these animals. Research has been done to compare basic motor function to neurological stimuli [2] and to evaluate basic grip strength [1]. Although these efforts have been effective, there currently is no method for testing the strength for any large muscle group. Large muscle groups, such as those on the arms and legs, are more effective to test since they are most often the muscle groups that are biopsied by researchers. Due to this, there is a need for an apparatus that is capable of evaluating the major muscle groups' maximum strength in a safe and effective way.

- ❖ **Physical Function Testing Apparatus for Monkey**.....1
  - **Abstract** .....1
  - **Introduction** .....3
    - **Problem Statement** .....3
  - **Background**.....3
    - **Rhesus Monkey Physiology** .....3
    - **Animal Testing Regulation**.....3
    - **Client Information** .....4
    - **Motivation** .....4
    - **Competing Designs** .....4
    - **Design Specifications**.....5
  - **Design**.....6
    - **Original Design** .....6
    - **Considered Designs** .....7
      - ◆ **Hinged Design** .....7
      - ◆ **One Piece Screwed Clamp** .....8
    - **Dimensions**.....9
    - **Circuit Designs**.....9
    - **Design Matrices** .....9
      - ◆ *Clamp Design Matrix* .....10
      - ◆ *Circuit Matrix*.....12
      - ◆ *Materials Matrix* .....13
    - **Proposed Final Design** .....14
  - **Future Work**.....15
    - **Materials** .....15
    - **Fabrication**.....15
    - **Testing** .....16
  - **References** .....16
  - **Appendix** .....17
    - **A. PDS** .....17
    - **B. Testing Protocol** .....20
    - **C. Code** .....21
    - **D. Software and Hardware Diagrams** .....25
    - **E. Design Dimension Drawings**.....26
    - **F. Materials Spreadsheet**.....27

## **Introduction**

### ***Problem Statement***

In studying the muscular effects of calorie-restricting diets and their impact on aging, Rhesus monkeys must be assessed for muscle strength. Current methods simply accurately measure muscle mass, which only loosely correlates with muscular function. The Wisconsin National Primate Research Center (WNPRC) requires an apparatus that intuitively allows monkeys to complete a range of motion under resistance and delivers quantitative feedback on leg strength. The goal of this project is to develop a safe, durable, and easily sanitizable device that meets this goal.

## **Background**

### ***Rhesus Monkey Physiology***

Due to their similar anatomy to humans, data from Rhesus macaque medical studies can be extrapolated to human health [3]. Rhesus macaques are quadrupedal with opposable toes, enabling them to grip with their feet as well as hands. This increased range of motion provides more possibilities for muscle movements, but offers more challenges in finding ways to isolate the muscle groups. Despite their small size, averaging around 15 pounds, their high strength-to-weight ratio allows them to produce surprisingly large forces [3]. To obtain muscle mass data, biopsies are often taken from the quadriceps because of the muscle group's large amount of tissue and quick recovery time. According to Dr. Colman, scientists choose to avoid the core when taking biopsies because this would have more complications and further inhibit the animal's recovery.

### ***Animal Testing Regulation***

The majority of medical advances have been founded on animal research. This trend lessens the risk of transitioning new practices to human application. Discoveries ranging from vaccine breakthroughs to behavioral disorders are outcomes of non-human primate tests [4]. To ensure humane research and optimal results, animal-testing protocols are observed. Conditions corresponding to the transfer of animals, materials used, husbandry and colony management, pain experience, surgery,

sanitation and safety, among others, are all regulated to minimize unnatural stressors to adaptable levels [5].

The Wisconsin National Primate Research Center exhibits high standards in humane animal care. A device measuring primate strength must adhere to its policies. The Animal Welfare Act (AWA) and Health Research Extension Act determine primate maintenance protocol [5]. Safety hazards such as exposed wires, sharp edges, and breakable parts pose safety risks to animals and must be prevented.

### ***Client Information***

Dr. Colman's research at the Wisconsin National Primate Research Center concentrates on variation in muscular function and chronic disease rates due to caloric restriction. With age comes higher susceptibility to chronic diseases rooted in metabolic abnormalities. Dr. Colman's research indicates that caloric restriction may stave off these diseases, including cancer, obesity, and diabetes [6]. With aging, rhesus monkeys and humans experience natural muscle loss, a condition called sarcopenia [7]. Although incapable of full prevention, long-term dietary alterations can slow sarcopenia. Testing this theory on rhesus monkeys may someday provide a valid human treatment.

### ***Motivation***

While muscle mass data is accurately obtainable through methods such as x-ray imaging, aging studies, lean body mass calculations, and quadricep analyses during necropsies [6], physical function and strength of individual muscle groups cannot yet be quantitatively measured. A device to generate these measurements would provide the missing link for Dr. Colman's research in examining the long-term effects of caloric reduction on muscle composition.

### ***Competing Designs***

In assessing monkey strength, numerous competing devices follow two common practices: a reward, often in the form of food, is provided upon completion of a specific motion against a certain resistance, and resistance behind that motion is increased per trial to reach maximum strength. Motions utilized by these devices typically include gripping and pulling a weighted-sled. Once a maximum force is observed, it is divided by the monkey's weight to normalize measurements among separate individuals. While applicable to and optimal for many studies, these devices are not ideal in light of Dr. Colman's preferences for this project.

The first competing design, implemented by Bury SD et al. in a study to understand grip-behavior by normal and neurologically impaired squirrel monkeys, is a small force transducer within a bisected aluminum cylinder. As a monkey squeezes the cylinder, surfaces of the two aluminum halves contact each other and allow the force transducer to collect data. The grip-cylinder is mounted to a three-axis, sliding frame by a universal joint, which prevents normal and moment forces imparted by body-parts other than the hands from altering force data. Monkeys are provided a reward upon each squeeze at a specified force. This design is advantageous in its simplicity and intuitiveness to the monkeys. However, it is not ideal for Dr. Colman's research, which aims to assess leg strength rather than forearm strength [1].

The second competing design, implemented by Bozek et al. in a study to understand the evolutionary divergence of human, chimpanzee, and macaque monkey strength, is a sled with adjustable weight that is dragged against an even surface by a rope. Between the sled and rope is a linear force gauge, which measures the maximum force produced while pulling the sled during a specific trial. Using its entire body, a chimpanzee or macaque monkey pulls the sled towards its enclosure to receive an attached reward. This design is advantageous in its simplicity, intuitive use, and cost-effectiveness. However, it does not encourage a standard motion to produce a force -- allowing for many pulling strategies -- and therefore does not produce accurate data. It is not ideal for this project in that it does not isolate leg movement [2].

### ***Design Specifications***

An apparatus that tests rhesus monkey strength must be fully functional, safe, and durable before animal exposure. Due to strict animal-testing regulations, the device must be safe in all possible scenarios of usage. There cannot be any exposed wires or sharp edges and animal escape must be made impossible during setup and testing. The device must be easily sanitized and rust resistant. It must be weighted and shaped so that one person is able to attach the device to varying cage designs. Lastly, a reward system must be in place to positively reinforce the animal. This system, coupled with training that the client will provide, should ensure maximum effort from the monkey and the most accurate results. The apparatus must be intuitive enough to require minimal animal training (Appendix A).

## Design

### *Original Design*

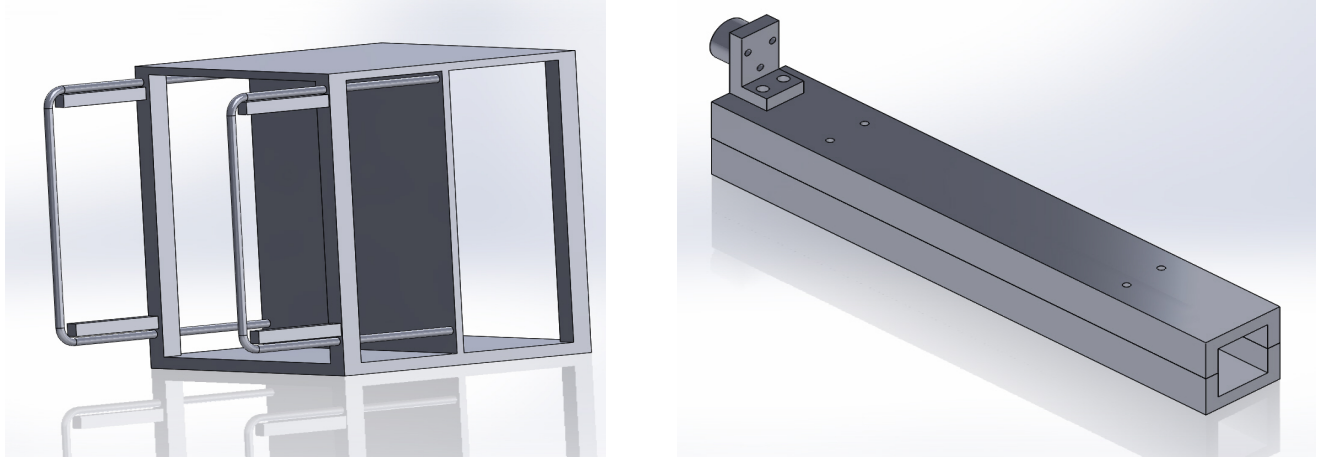

The original design implemented force gauges by attaching them to the bars connected to the squeeze plate. The squeeze plate would be brought towards the front of the cage. The force gauges would then be attached to the bars, which are now extended past the front of the cage. These gauges would prevent the monkey from pushing the squeeze plate back, while measuring the force placed upon the squeeze plate as the monkey pushes on it. The monkey would push back against the squeeze plate with their legs, as it is natural behavior to do so according to the client. This natural behavior would be reinforced with a reward system similar to the other designs, allowing the apparatus to acquire the maximum strength of the monkey's legs.



The final fabricated device is shown above attached to the squeeze plate on the exterior of the cage. Results from testing show that the device was able to measure

forces correctly within a range. Calibration of the device was effective and easy to accomplish. Since calibration could be done in real time, the load cell was relatively accurate. When implemented, the device could be attached to either of the bottom bars. However, the device could not be attached to the top bars due to the different geometries between the top and bottom bars.

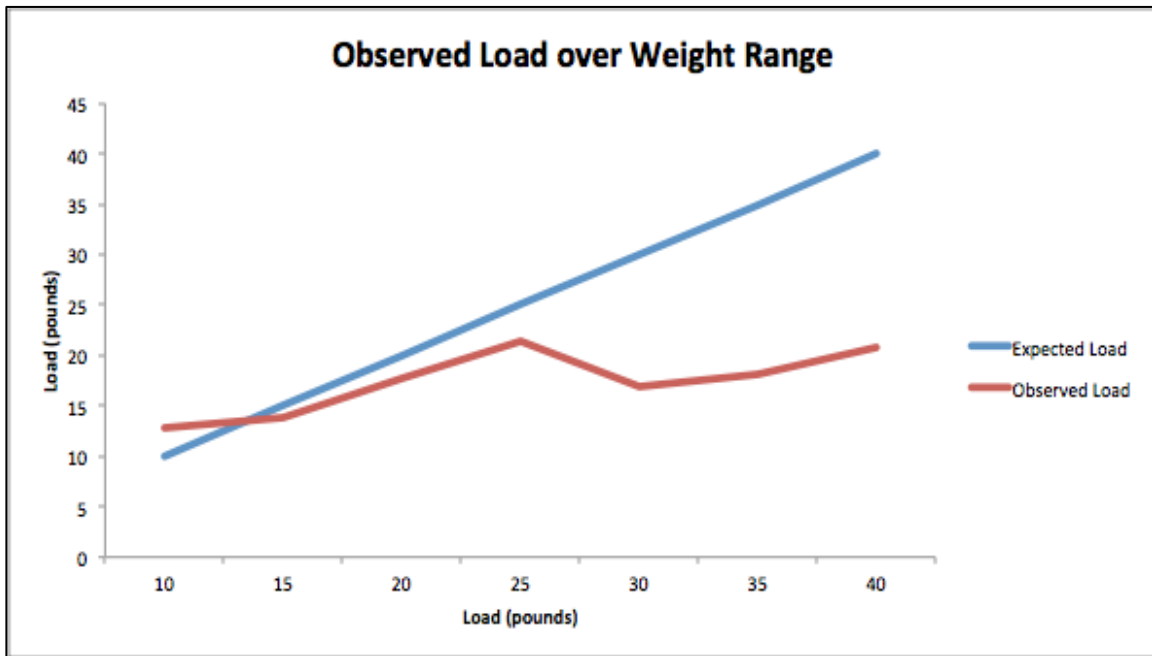

The figure above shows the results from our preliminary testing of the original device. The device was accurate in the 0-20 pound load range; however, at loads above 20 pounds the device was no longer accurate. This occurred because of moments generated about the three other corners that remained unclamped. To account for this, four devices will be made this semester and place in each of the corners.

### ***Considered Designs***

#### **Hinged Design**

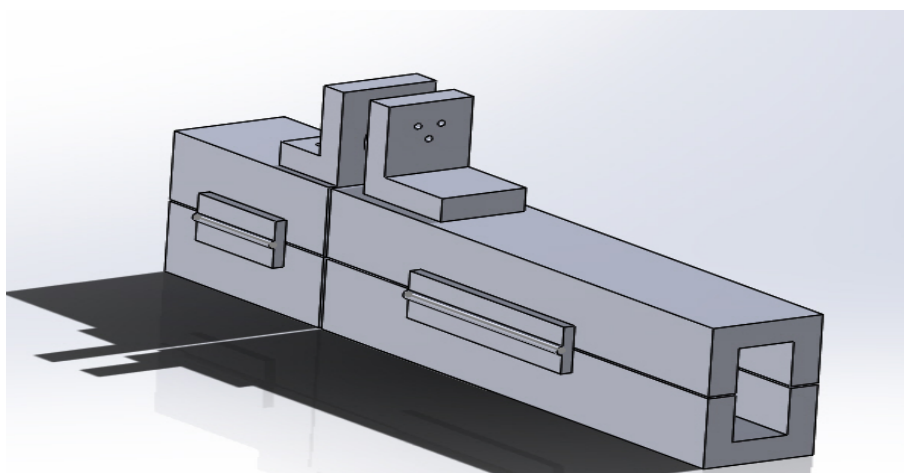

The hinged design was intended to make the device easier to attach for the researcher as well as reduce the size and weight of the overall design. This design features the same L shaped piece on the top of the device for load cell attachment that was featured on the original design. One difference between this design and the original design is that this design has a smaller width of the clamp. This change creates contact with the bar and interior walls of the device on all sides. This will increase the frictional force generated as the monkey pushes on the squeeze plate. The new hinge and lock system on the outside of the device allows the design to be attached easily by the researcher. The hinge on one side keeps the pieces attached when not in use and allows for easy alignment of the device on the bars. The main issue with the hinges and locks is that they isolate the majority of the force to individual points creating likely fail points.

The addition of a second piece can be seen in the figure above. This new feature is not isolated to the hinged design, and will be incorporated with all possible designs. This piece (2 inches long) is much smaller than the main design piece (5 inches long). It is being added to produce a flat, consistent surface for the load cell to pin against and register forces. The inside of this piece will not be lined with the foam used in the main device. This is to minimize frictional forces in the small piece, so that only the main device acts to pin the squeeze plate.

### One Piece Screwed Clamp

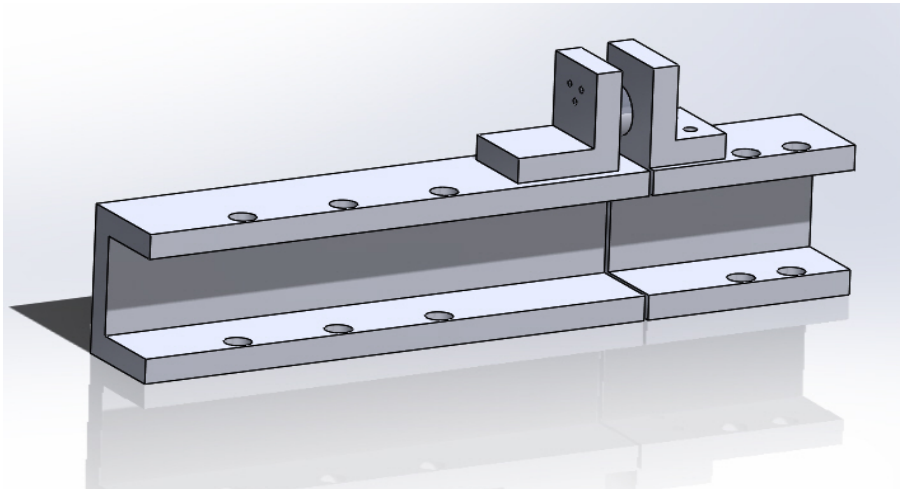

This design utilizes screws and bolts to generate the clamping method. With the foam inserts lining the inner walls of the device, the squeeze plate bars can be slid into the device's C shape and screwed into place on the open side. This allows for bar/device contact on three sides, increasing the frictional force from the original design. This device reduces the difficulty of fabrication significantly by only having to remove a



side of the square pipe used. Also, the open side reduces the difficulty of attachment from the original design because the researcher can see the screw and bar locations inside the device. The original device was enclosed and had no visibility. As prior stated, this design also utilizes a second, smaller piece to create a flat consistent surface for the load cell.

### ***Dimensions***

Drawings with specific dimensions are found in Appendix E.

### ***Circuit Designs***

Since the new designs contain four load cells, the original circuit must also be adjusted to account for this change. Two options were considered to replace the circuit. The first design uses four separate circuits, one for each load cell, and combines the data in the code. This design, though safer because there is less wiring for the monkeys to break, is also significantly more expensive. The second circuit design, which will be implemented into our prototype, uses a combinator load device that is attached to all four of the load cells. This combinator load sends only one signal to the op amp, which further sends only one signal to the Arduino. The combinator load cell only costs \$2, saving a significant amount of money in comparison to the other design.

### ***Design Matrices***

There were three independent aspects of the design, which were evaluated separately. First and foremost, the three clamp designs were evaluated. Next to be assessed were three different possibilities for creating the electrical circuit. Finally, aluminum and stainless steel were compared in the materials matrix. Although each matrix holds different criteria, it was the safest, most convenient and most accurate designs that were chosen to be realized.

## Clamp Design Matrix

	Original Clamp		Hinged Clamp		One Piece Screwed Clamp	
Safety (25)	4	20	3	15	4	20
Durability (20)	5	20	3	12	4	16
Ease of Fabrication (20)	4	16	3	12	4	16
Ease of Use (Researcher) (20)	2	10	5	20	4	16
Measurement Accuracy (10)	5	10	5	10	5	10
Cost (5)	5	5	4	4	5	5
<b>Total (100)</b>		<b>81</b>		<b>73</b>		<b>83</b>

### Safety

Safety is by far the most important aspect of this design because the monkeys will touch, pull, and bite this device it must be completely safe and not cause any harm to the animals. The Original Design is fairly safe because it has very few moving parts and the only way the monkeys could injure themselves is getting pinched on the sides of the plate. In the hinge design, the lock could possibly be released by the monkey, which could lead to the monkey pinching their self in the clamp. The Screw Design has the least moving parts and the only chance of injury to the monkey would be if he or she were to get pinched by the screw and nut. All of the designs run this risk though. Also, none of the designs pose a significant risk of injury to the researcher.

### Durability

Durability is very important to this project because our client's research lasts years and she must be able to test the same muscle force in the same way over her experiments. The Original design has the fewest moving parts and the fewest screw

holes, both of which act as possible points of failure. The Hinged Clamp has the most moving parts with the lock and hinge, along with some drill holes to screw the hinge in. The One Piece Screwed Clamp's main risk is the screw holes, which would most likely have to be drilled toward the edge of the metal piece, which increases its chance of failure.

### **Ease of Fabrication**

Ease of fabrication is very important, considering at least four devices will be created. Additionally, if the fabrication process were simple, it would be easier to make modifications if necessary. Primarily, only a strip of rectangular metal piping will need to be cut, and a few holes drilled for each of the designs. Having to fit the hinges and locks onto the Hinge Clamp adds another factor for its fabrication, which is why it was rated lower than the others.

### **Ease of Use - Researcher**

Ease of use was weighted moderately heavily because for any of the designs to be feasible the researcher must be able to install the device and motivate the monkey to use it properly. The Original Clamp required the researcher to match up the two plates in order to screw them together and this task proved to be tedious. The Hinge Clamp would be the simplest to use, as it would only need to be closed and locked into place. Finally, the Screwed Clamp would be relatively easy to use because the screw holes are already aligned and only one piece needs to be held up as the screws are tightened.

### **Measurement Accuracy**

Accuracy of Measurement is important because without accurate measurement of muscle force the device does not perform its purpose. All of the designs were rated equally because, if fabricated well, they would all apply enough friction to the cage bars so that they would hold in place, and the load cell would be pushing against a flat surface. If all four bars were fitted with one of the clamps, it would remove the moment forces that altered the test results in the previous semester.

### **Cost**

Cost was weighted as the least important criteria because there was no strict limit on the budget as long as the design was functional and reasonably priced. However, this category was included to guarantee that the designs were cost effective. Every design incorporates a similar amount and type of bulk material (either stainless steel or aluminum) so the scores are similar. However, the Hinge Clamp requires the extra hinges and locks which would increase cost.

### Circuit Matrix

	Original Circuit		Quadruple Circuit		Combined Circuit	
Cost (30)	5	30	2	12	4	24
Accuracy (30)	1	6	5	30	5	30
Ease of Fabrication (20)	4	16	3	12	5	20
Safety (10)	1	2	5	10	4	8
Ease of Use (Researcher) (10)	1	2	5	10	5	10
<b>Total (100)</b>		56		74		92

#### Cost

The original circuit was the cheapest option (5) because it was already purchased along with all of the supplies necessary for a working circuit. The combined circuit was ranked a 4 because it only requires the purchasing of more wiring along with the combinator board which costs \$2. The quadruple circuit was rated a 2 because it would require 3 more Arduinos, 3 more op amps, and more wiring. This would cost hundreds of dollars.

#### Accuracy

The quadruple circuit and the combined circuit were both ranked 5 because they would accurately measure the total load the monkey places on the squeeze plate. The load is divided among the four corners of the device, and the four load cells in these circuits would measure all four of those forces. The current device was given a 1 because it only measures one force on the exterior of the cage. It has already been shown through testing that this isn't accurate above loads of 20 pounds.

#### Ease of Fabrication

The combined circuit was rated highest for ease of fabrication (5) because it simply adds the four load cells together using the combinator, and this organizes the circuit well. The current circuit was given a 4 because although it is already fabricated, it is not very organized. The

wires fall out from the Arduino, and the overall fabrication was done somewhat poorly. The quadruple circuit was given a score of 3 because it would require fabricating four separate circuits, and this would also be complicated when it came to writing the code for all four.

### Safety

The quadruple circuit was given a score of 5 because it is completely out of reach from the rhesus monkeys. The wires are covered up completely in boxes and will not harm the monkeys in any way. The combined circuit was given a score of 4 because the wires should be out of reach from the monkeys, but they will not be completely covered in a box. The current circuit was given a score of 1 because the wires are not only uncovered, but they can also be reached by the monkeys. This is a major concern as far as safety goes.

### Ease of Use (Researcher)

The combined circuit and the quadruple circuit were given a score of 5 because the user simply has to connect the four load cells to the clamps and turn on the code in order to gather data. The current circuit was given a 1 because some of the wiring has to be connected, and the device has to be connected to a computer. The two new designs take advantage of Bluetooth.

### Materials Matrix

	Stainless Steel 304		Aluminum 2024	
Strength (25)	5	25	4	20
Ease of Fabrication (25)	2	10	4	20
Weight (20)	2	8	4	16
Cost (15)	4	12	5	15
Durability/ Corrosion Resistance (15)	5	15	4	12
<b>Total (100)</b>		<b>72</b>		<b>83</b>

## **Strength**

Rhesus monkeys are deceptively powerful and a material that can withstand high compressive forces and has a high yield stress is required. Strength was rated highly because a device that fails would need to be re-fabricated and also poses a risk to injure the monkeys. Both stainless steel and aluminum have very high compressive strength, and with four devices on the cage, pose a very low risk of failure due to lack of strength. However, stainless steel is slightly stronger.

## **Ease of Fabrication**

Ease of fabrication is vital both for the fabrication team and for maintaining the device during use. A material that can be fabricated in a timely manner would make the device more convenient for the client and the fabrication team, especially if changes need to be made to the design. Since we are making a device for each of the four bars, a material that can be manufactured quickly would be very beneficial. Aluminum is praised for its manufacturability while stainless steel takes a significantly longer time to fabricate.

## **Weight**

The client requested that the new version of the device be lighter for the convenience of the researchers using the device. However, our design team does not want to sacrifice convenience of the client for functionality of the device, which is why the weight is not the highest priority in the matrix. Aluminum is several times less dense than stainless steel.

## **Cost**

Although there hasn't been a budget prescribed by the client, it is necessary to make sure that the price of the material doesn't drive up the overall cost of product. Aluminum 2024 and stainless steel 304 are both very similar in price range, although stainless steel is slightly more expensive by volume.

## **Durability/Corrosion Resistance**

The devices are meant to withstand many tests over a long period of time without failing and should be resistant to rusting. Both of these materials will confidently be able to meet this requirement for a significant time period so the category was not weighted highly. However, stainless steel is extremely resistant to corrosion, and aluminum is a softer metal. Therefore, stainless steel ranked higher, although aluminum alloy is durable and resistant to corrosion.

## ***Proposed Final Design***

After completing the design matrix analysis, the proposed final design is the open piece screwed clamp. This design will be fabricated using aluminum. The load cells will run through a combined circuitry system utilizing a combinator.

## **Future Work**

The work for the rest of the semester begins with ordering our materials for the circuit and the clamp. The circuit materials are estimated to cost around \$175, and the cost of the clamp material is still to be determined. Another key step is to begin the process to gain access to the monkey subjects so that we can test the device on them later in the semester. Once our materials have arrived, fabrication of the four devices, calibrating them, and testing them in an empty cage will begin. Then, the data will be evaluated and any adjustments necessary will be made. Assuming the device is working as expected, it will be tested on a cage with a monkey subject. Again, the data and results will be evaluated, and then the design decisions will be re-evaluated.

## ***Materials***

The materials that need to be ordered are listed in Appendix F. The URL and product numbers are provided for any confirmed product orders.

## ***Fabrication***

The fabrication will begin by cutting a 7 in long piece of pipe off. A sharpie line will be drawn at 2 in. from one end. Three  $\frac{1}{8}$ " holes will be drilled a quarter inch from the line on the short segment. The same three holes will be drilled  $\frac{3}{4}$ " from the line on the long segment. Following this 5  $\frac{1}{4}$ " holes will be drilled on the side that is eventually going to be open. On the long segment, three holes will be drilled  $\frac{1}{4}$ " from the side and every inch from the far side of the segment. On the short segment, two holes will be drilled  $\frac{1}{4}$ " from the side and every half inch from the far edge from the sharpie line. Very carefully, the side of the aluminum pipe with the holes will be sawed off until the side is open. Following this the sharpie line will be sawed along to separate the pieces. All corners and edges will be grinded down. From another piece of aluminum pipe, two L shaped pieces that are  $\frac{1}{2}$ " long x  $\frac{1}{2}$ " wide x  $\frac{3}{4}$ " tall will be cut out and grinded down to remove all sharp edges. Both pieces will have three  $\frac{1}{8}$ " holes drilled into the bottom side. One of the L pieces will have the same holes drilled into the other side as well for attaching the load cell. These will be attached to the other pieces by  $\frac{1}{8}$ " screws and cover bolts that are pushed from attached from inside the device to the outside. The L piece with holes on both sides will be attached to the larger piece. The load cell will be attached with  $\frac{1}{8}$ " screws to the L piece on the larger piece. Foam will be cut out and lined to the inside of only the large piece.

## Testing

The preliminary testing will begin without the monkeys to ensure the device is working properly. The device will be attached to an empty cage and tested manually by a human user. If the device is working properly, it should allow for the client to see changes in forces in the feedback system. After this testing, the device should be integrated into a cage with a monkey and tested again. This will allow for the device to be tested again, and the client should be able to begin gathering some preliminary data. This secondary test will also allow for the durability of the product while also testing for the response the rhesus monkeys will give to the product. Ideally, the monkeys will not destroy the product in any fashion and will also quickly realize that interaction with the test allows for some reward. After these preliminary tests, necessary improvements will be made in order to reach the clients design requirements.

## References

- [1] Bury, S. D., Plautz, E. J., Liu, W., Quaney, B. M., Luchies, C. W., Maletsky, R. A., & Nudo, R. J. (2009). A novel device to measure power grip forces in squirrel monkeys. *Journal of Neuroscience Methods*, 179(2), 264–270.  
<http://doi.org/10.1016/j.jneumeth.2009.02.003>
- [2] Bozek, K., Wei, Y., Yan, Z., Liu, X., Xiong, J., Sugimoto, M., ... Khaitovich, P. (2014). Exceptional Evolutionary Divergence of Human Muscle and Brain Metabolomes Parallels Human Cognitive and Physical Uniqueness. *PLoS Biology*, 12(5), e1001871.  
<http://doi.org/10.1371/journal.pbio.1001871>
- [3] Cawthon Lang KA. (2005, July 20). *Primate Factsheets: Rhesus macaque (Macaca mulatta) Taxonomy, Morphology, & Ecology* [Online]. Available: [http://pin.primate.wisc.edu/factsheets/entry/rhesus\\_macaque/taxon](http://pin.primate.wisc.edu/factsheets/entry/rhesus_macaque/taxon)
- [4] (2015, January 28). *Contributions of Nonhuman Primate Research to Human Health* [Online]. Available: <http://pin.primate.wisc.edu/research/discoveries.html>
- [5] R. A. R. Center. (1996). *Animal Health* [Online]. Available: [https://www.rarc.wisc.edu/animal\\_health.html](https://www.rarc.wisc.edu/animal_health.html)
- [6] R. J. Colman *et al.*, “Muscle mass loss in Rhesus monkeys: Age of onset,” *Exp. Gerontol.*, vol. 40, no. 7, pp. 573–581, 2005.
- [7] L.-K. Chen *et al.*, “Recent Advances in Sarcopenia Research in Asia: 2016 Update from the Asian Working Group for Sarcopenia,” *J. Am. Med. Dir. Assoc.*, vol. 17, no. 8, p. 767.e1-767.e7, Aug. 2016.



## Appendix

### A. PDS

#### Physical Testing Apparatus for Monkeys PDS

**Client:** Dr. Ricki Colman

**Advisor:** Dr. Beth Meyerand

**Team:** Naren Chaudhry, Benjamin Myers, Benjamin Ratliff, Eli Stanek

#### Problem Statement:

In studying the effects of diet on the rhesus macaque monkey, muscle function and strength give important data to the aging of the test subjects. Currently, only muscle mass can be measured; however, information on the animal's' muscle strength lacks. An apparatus to motivate the monkeys to test their strength, exercise their upper and lower body, and give feedback, isn't available in the primate center on the UW campus. The goal of this project is to develop a method for testing the physical function of the hind and forelimbs of a macaque monkey that will be durable, able to be sanitized, and safe for the animals.

#### Client Requirements:

- 1) The device must be able to measure the strength of a rhesus monkey.
- 2) The device must be sanitizable.
- 3) The device must not be harmful to the monkey.
- 4) The device must be durable enough to withstand long-term abuse from a monkey.
- 5) The device must be resistant to rust.
- 6) The device must be able to be operated by a monkey after training.
- 7) The device must be able to give feedback to the client in real time.
- 8) The device must be able to measure the strength of the monkey's arms and legs separately.
- 9) The device must be able to be moved by a single person.
- 10) The device must have a way to reward the monkey with food.

#### Preliminary Product Design Specifications

#### Physical and Operational Characteristics:

##### a. Performance Requirements:

The physical testing apparatus for rhesus monkeys should be wear-and-tear resistant with long term durability. The apparatus must be able to test rhesus monkey

upper body and lower body strength separately, while providing feedback to the user. The rhesus monkeys are very strong, so the device must be able to withstand large forces from the monkeys.

*b. Safety:*

The device should meet all of the regulations for animal testing established by the Institutional Animal Care and Use Committee (IACUC). The device cannot harm the animals in any way, and we must be careful to design a device that is still safe even if used incorrectly. The device also must be made using a metal that cannot rust, likely stainless steel.

*c. Accuracy and Reliability:*

The device must be able to accurately and reliably relay data to the client on the strength of the animals. Ideally, the device returns leg strength and arm strength as two separate sets of data.

*d. Life in Service:*

The client did not give any specific description into life in service; however, the device will be used several times a day and should be able to last at least a year. The device will be under constant stress while in use, so it must be able to withstand high forces from the animals.

*e. Shelf Life:*

The device should be able to maintain the wear and tear damage while in use with the monkeys. The client stressed the strength of the monkeys and their ability to break devices easily.

*f. Operating Environment:*

The device will primarily be used in the cages that the rhesus monkeys are currently kept in. As a result, the biggest factor of the operating factor are the monkeys themselves. The device also must remain rust free over time.

*g. Ergonomics:*

The testing apparatus must be able to withstand the full strength of the monkeys. It must be easy to use for the monkeys and motivate them to use their full strength.

*h. Size:*

The product should be able to work on different sized cages. It must be detachable so that it can be fully sterilized. It should be portable enough to move from one cage to another. It should have a maximum weight of 40lbs.

i. *Power Source:*

The product can be outlet or battery powered.

j. *Weight:*

The strength testing device should not exceed 40lbs.

k. *Materials:*

All parts that are open to the monkeys should be made from metal or plexiglass so the monkeys can not destroy the equipment or hurt themselves with parts. The apparatus must be rust resistant too.

l. *Aesthetics, Appearance, and Finish:*

This product should have no sharp corners or edges that the monkeys could injure themselves on. It should be smooth enough that the monkeys cannot grab and destroy it. It must be rust resistant.

**Production Characteristics:**

a. *Quantity:*

The product may be produced on a larger scale, but a working prototype must be created first.

b. *Target Product Cost:*

The current product cost is \$500.

**Miscellaneous:**

a. *Standard and Specification:*

The strength testing apparatus must be able to gauge force produced by macaque monkeys during specific forelimb and hindlimb movements and export readings to a data collection interface. It must be attached to and functioned within monkey cages, easily detached and transported, resistant to animal-abuse, dishwasher-safe, and operated without mechanical, electrical, chemical, or biological hazards to the animals. Properties and usage of the device must fall under AWA (Animal Welfare Act) regulations.

b. *Patient-Related Concerns:*

Our client's most significant concern is the safety of the device, as aforementioned. In their perspective, our greatest challenge will be creating an apparatus that the monkeys will use properly and consistently. Preferences include minimal requirement of animal and human training to use, reinforcing monkey compliance with an automated reward

system, not using physical restraints, and using washable, corrosion and oxidation-resistant materials (such as plexiglass and stainless steel). Our client is in favor of operating the device in environments familiar to the monkeys, such as individual cages, to maximize the subjects' comfortability.

*c. Competition:*

Several monkey-strength testing devices built for individual studies exist. Each mechanism is used with increasing resistance over trial number, and supplies a reward after each successful trial as positive reinforcement. For example, a device utilized by Katarzyna Bozek et al. consists of a sliding shelf attached to a handle on one side, and suspended adjustable weights on the other. Sufficient displacement of the shelf brings food within the subject's reach. Another example is a device utilized by Bury SD et al. that measures grip strength through the squeezing of two halves of an aluminum cylinder against an internal force transducer. If sufficient force is provided, food is dispensed as a reward.

*d. Customer:*

Our client is Dr. Ricki Colman, PhD, an expert on primate aging, caloric restriction, and primate models as well as an associate scientist at the Wisconsin National Primate Research Center.

## **B. Testing Protocol**

### Testing Protocol for Monkey Strength Test

#### Calibration Testing for Product

In order to calibrate the load cell and Matlab code, the device was subject to a series of known weights that were placed on top of the sensor. These weights ranged from 5 to 15 pounds with a 5 pound incremental increase. The expected forces for the weights are  $F = ma$ , where  $m$  is the mass of the weight and  $a = 9.8 \text{ m/s}^2$ . Using this series of weights, the load cell was calibrated and was ready for further testing.

#### Test with Monkey Cage

The device was connected to the squeeze plate in one of the four corners on the exterior of the cage - the same location that will be used by the client. Using an empty cage, a measured force was applied to the back of the squeeze plate in order to test whether the device was functioning correctly. The force at the back of the squeeze plate will range from 10 to 40 pounds at 5 pound increments. The force will be read by pushing on the squeeze plate with a scale. Ideally, the single force sensor reads the entire force applied because the squeeze is on a track, preventing

moments from occurring. However, this is not a perfect system, and a moment could possibly be generated. Using four force sensors, the force would be distributed among them, and any moment generated would be measured by the sensors. The load cell was tested in all four corners to ensure that it can be attached on the various bars on the exterior of the cage.

## Test with Monkeys

In the future, the device will be implemented onto a cage with a rhesus monkey inside. Four devices will need to be attached on the four corners of the cage. The circuit must be expanded to include an automated food dispenser that provides motivation to the monkey as they continue to generate forces. By this time, the device will already be calibrated, and our client should be able to begin generating some data.

## C. Code

### *Calibration*

*/\**

Example using the SparkFun HX711 breakout board with a scale

By: Nathan Seidle

SparkFun Electronics

Date: November 19th, 2014

License: This code is public domain but you buy me a beer if you use this and we meet someday (Beerware license).

This is the calibration sketch. Use it to determine the `calibration_factor` that the main example uses. It also outputs the `zero_factor` useful for projects that have a permanent mass on the scale in between power cycles.

Setup your scale and start the sketch WITHOUT a weight on the scale

Once readings are displayed place the weight on the scale

Press +/- or a/z to adjust the `calibration_factor` until the output readings match the known weight

Use this `calibration_factor` on the example sketch

This example assumes pounds (lbs). If you prefer kilograms, change the `Serial.print("lbs");` line to `kg`. The calibration factor will be significantly different but it will be linearly related to lbs (1 lbs = 0.453592 kg).

Your calibration factor may be very positive or very negative. It all depends on the setup of your scale system

and the direction the sensors deflect from zero state

This example code uses bogde's excellent library: <https://github.com/bogde/HX711>

bogde's library is released under a GNU GENERAL PUBLIC LICENSE

Arduino pin 2 -> HX711 CLK

3 -> DOUT

5V -> VCC

GND -> GND

Most any pin on the Arduino Uno will be compatible with DOUT/CLK.

The HX711 board can be powered from 2.7V to 5V so the Arduino 5V power should be fine.

```
*/
```

```
#include "HX711.h"
```

```
#define DOUT 3
```

```
#define CLK 2
```

```
HX711 scale(DOUT, CLK);
```

```
float calibration_factor = -7050; //-7050 worked for my 440lb max scale setup
```

```
void setup() {
```

```
  Serial.begin(9600);
```

```
  Serial.println("HX711 calibration sketch");
```

```
  Serial.println("Remove all weight from scale");
```

```
  Serial.println("After readings begin, place known weight on scale");
```

```
  Serial.println("Press + or a to increase calibration factor");
```

```
  Serial.println("Press - or z to decrease calibration factor");
```

```
  scale.set_scale();
```

```
  scale.tare(); //Reset the scale to 0
```

```
  long zero_factor = scale.read_average(); //Get a baseline reading
```

```
  Serial.print("Zero factor: "); //This can be used to remove the need to tare the scale.
```

```
  Useful in permanent scale projects.
```

```
  Serial.println(zero_factor);
```

```
}
```

```

void loop() {

  scale.set_scale(calibration_factor); //Adjust to this calibration factor

  Serial.print("Reading: ");
  Serial.print(scale.get_units(), 1);
  Serial.print(" lbs"); //Change this to kg and re-adjust the calibration factor if you follow
SI units like a sane person
  Serial.print(" calibration_factor: ");
  Serial.print(calibration_factor);
  Serial.println();

  if(Serial.available())
  {
    char temp = Serial.read();
    if(temp == '+' || temp == 'a')
      calibration_factor += 10;
    else if(temp == '-' || temp == 'z')
      calibration_factor -= 10;
  }
}

```

### *Load Cell*

```

/*
Example using the SparkFun HX711 breakout board with a scale
By: Nathan Seidle
SparkFun Electronics
Date: November 19th, 2014
License: This code is public domain but you buy me a beer if you use this and we meet
someday (Beerware license).

```

This example demonstrates basic scale output. See the calibration sketch to get the calibration\_factor for your specific load cell setup.

This example code uses bogde's excellent library: <https://github.com/bogde/HX711>  
 bogde's library is released under a GNU GENERAL PUBLIC LICENSE

The HX711 does one thing well: read load cells. The breakout board is compatible with any wheat-stone bridge based load cell which should allow a user to measure everything from a few grams to tens of tons.

Arduino pin 2 -> HX711 CLK  
3 -> DAT  
5V -> VCC  
GND -> GND

The HX711 board can be powered from 2.7V to 5V so the Arduino 5V power should be fine.

```
*/
```

```
#include "HX711.h"
```

```
#define calibration_factor -7050.0 //This value is obtained using the  
SparkFun_HX711_Calibration sketch
```

```
#define DOUT 3
```

```
#define CLK 2
```

```
HX711 scale(DOUT, CLK);
```

```
void setup() {
```

```
  Serial.begin(9600);
```

```
  Serial.println("HX711 scale demo");
```

```
  scale.set_scale(calibration_factor); //This value is obtained by using the  
SparkFun_HX711_Calibration sketch
```

```
  scale.tare(); //Assuming there is no weight on the scale at start up, reset the scale to 0
```

```
  Serial.println("Readings:");
```

```
}
```

```
void loop() {
```

```
  Serial.print("Reading: ");
```

```
  Serial.print(scale.get_units(), 1); //scale.get_units() returns a float
```

```
  Serial.print(" lbs"); //You can change this to kg but you'll need to refactor the  
calibration_factor
```

```
  Serial.println(); }
```



## D. Software and Hardware Diagrams

### Load Cell Software Diagram

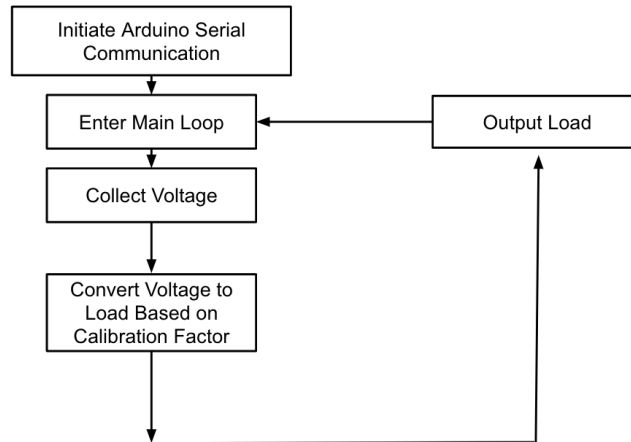

*Figure:* This figure is of the software diagram associated with the load cell readings. It depicts the loop statement that initially takes in the Arduino serial communication and converts the registered voltage to loading force data.

### Hardware Block Diagram

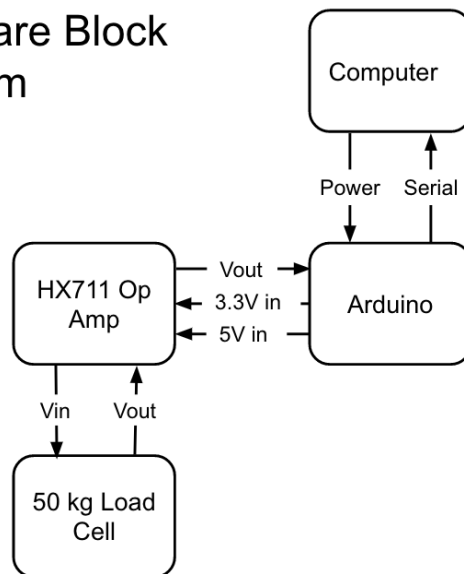

*Figure:* This figure is of the hardware diagram associated with the load cell to computer circuitry. The computer powers the Arduino which passes voltage to the op amp to read in voltages from the load cell and return this data to the computer.



