

# Power Tool Operation Injuries - Rat Model

BME 301

04/7/2019

Clients: Prof. Radwin (UW-Madison) & Prof. Barbe (Temple University)

Advisor: Prof. Witzenberg (UW-Madison)

## Team Members:

Mengizem Tizale (Leader)

Yash Gokhale (Communicator)

Carlos Veguilla (BSAC & BPAG)

Luke Hetue (BWIG)

# Abstract

Our team assisted in our clients research on the effects of industrial power tools and their cause of workplace musculoskeletal disorders (WMSD's). Our project proposes to use rats as analogous models to better understand these injuries. We created a device which provides eccentric loads to the rats. This system is a dynamic system that involves a linear actuator and a load cell that apply and measure forces respectively. A novel circuit was implemented by our team to control the device and a mount was fabricated to match current specs of the client's static systems. We found the performance of the circuit to be robust. However, the tests were done with a replacement linear actuator since the desired linear servo and its microcontroller were not received on time. The team looks to implement the chosen linear servo and have a working system of the desired size soon.

# Table of Contents

<b>Abstract</b>	<b>1</b>
<b>Introduction</b>	<b>3</b>
Motivation	3
Existing Devices	4
Problem Statement	5
<b>Background</b>	<b>5</b>
Biology and Physiology	5
Current Model	6
Client	7
Design Specifications	7
<b>Preliminary Designs</b>	<b>8</b>
Designs Considered	8
<b>Preliminary Design Evaluation</b>	<b>10</b>
Design Matrix	10
Matrix Criteria	10
Final Design	11
<b>Fabrication &amp; Development Process</b>	<b>12</b>
Materials	12
Methods	13
Testing	13
<b>Results</b>	<b>15</b>
<b>Discussion</b>	<b>17</b>
Considerations	17
<b>Conclusion</b>	<b>18</b>
Findings	18
Future Work	19
<b>References</b>	<b>20</b>
<b>Appendix A - Preliminary PDS</b>	<b>21</b>
<b>Appendix B List of Materials</b>	<b>27</b>
<b>Appendix C Circuitry</b>	<b>30</b>
<b>Appendix D Testing Protocol</b>	<b>31</b>

## Introduction

This semester, the team is continuing its work on the design of a device that can simulate the use of power hand tools in rats. This work will be used to study the effects of repetitive use of industrial power hand tools like threaded fastener tools that create large impulses experienced by the user. Over time, these forces can cause chronic injuries.

The design will be a variation of an already existing device that can measure static forces applied by rats. This device will require rats to hold onto it and withstand the dynamic forces introduced by a linear actuator into the system for a desired period of time designated by the researcher.

The current objective of the team is to design a device while taking into account electrical and physical constraints. Eventually we will build a working apparatus to be used in research.

## Motivation

Today the workplace's leading cause of pain, suffering, and disability is work-related musculoskeletal disorders (MSD's) [1]. The Occupational Safety and Health Administration has attributed them to possibly over 600,000 injuries and illnesses. This in turn accounts for 34% of all work days lost according to the Bureau of Labor Statistics and costs up to \$20 billion annually in direct workers' compensation in addition to its even greater indirect costs. The focus of this project pertains to those MSD's that have to do with the arm and wrist. These cases are found especially in fields that require repetitive motion and exertion of the arm [2].

The exact causes of these disorders are not well known. So much so, that in the 2010 National Manufacturing Agenda of the National Institute of Occupational Safety and Health, it was recommended that biomechanical research be put into the cause of MSD's [3]. The focus of the project is to begin conducting tests on rats that will accurately replicate the use of power tools and hopefully induce MSD like symptoms to eventually analyze.

## Existing Devices

This design will be the next step to an already existing device. Currently there is an apparatus that measures static forces applied by trained rats. Rats are kept in an 10" x 12" x 4.75" acrylic box that has a small hole (2.5" x 0.4") located such that the rats are only able to use their front right limbs during testing [4]. There is a handle that is located 0.75" outside of the hole that the rats have successfully been trained to pull. The research conducted had an increasing regiment that required rats to pull harder over time in order to receive food pellets. This design and testing method has proven the efficacy of using an isometric pull test on rats to train them while also collect data. The proposed design will change the static nature of the current device into a dynamic one.

## Problem Statement

We aim to develop a device that contains a handle that a rat can be trained to pull which initiates a controlled rapid impulse force in the opposite direction that results in eccentric muscle contractions in the rat's arms, simulating repetitive power hand tool operation. The device must be adjustable so that trained rats can progress throughout the study. Both required force and

duration of pull should be able to be manipulated. The device will be mounted on a base that fits into the space available beside the current cage set up to replace the static measuring system.

## Background

### Biology and Physiology

Musculoskeletal disorders (MSD's) are injuries or pain that affect the musculoskeletal system of the body. This system is comprised of your bones, muscles, tendons, and ligaments and is controlled by your nervous system that is intricately woven throughout it. MSD's stem from nerve damage that affects other components of the musculoskeletal system.

Nerves that innervate the upper extremity leave the spinal cord in what is known as the brachial plexus, a complicated intertwining of nerve fibers, roots, and bundles [5]. These nerves will eventually form your medial, radial, and ulnar nerves that run down your arm and are the main source of feeling in your upper extremity. If these nerves are damaged in any way, loss of strength and feeling will occur. Repetitive motion can cause these nerves to become compressed, also referred to as being entrapped, thus compromising them and causing an MSD.

It has been shown that workers in many different fields that include repetitive tasks are affected by MSD's [6]. When it comes to working with industrial power tools we are concerned about the bone of the upper extremity. Bone structure can be manipulated by repetitive loading of the tissue [3][7]. With an increase in loading impulses generated by industrial power tools, it can be assumed that these tools would cause changes to the makeup of the underlying bones.

This change in makeup could be a cause to increases in chronic injuries. For example, bones of patients with MSD's were scanned and found to have increased blood flow and blood pooling [3][8]. This could mean the bone is inflamed and this in turn could put the subject at higher risk of injury. In a related study, it was found that forestry workers who were exposed to hand-arm vibrations were more prone to MSD's then those who just did manual labor in the same field [8].

## Current Model

The current device is known as the Vulintus Mototrak seen in Figure 1. The research team at Temple University currently runs its investigations using it. The Mototrak is a complete system that includes a cage, controller, behavior module, pellet dispenser, auto positioner, and the MotoTrak software. This system is currently a static system. It only measures a force generated by a rat that pulls on a handle. Figure 2 shows the progression of a rat pulling on the handle.

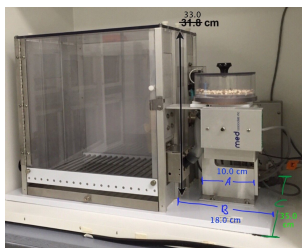

*Figure 1 - Vulintus Mototrak:*  
This is the Vulintinus Mototrak with the cage, controller, and pellet dispenser. Dimensions are being provided to show size of the cage and space.

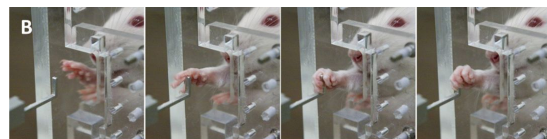

*Figure 2 - Rat reach, grasp, pull:*  
This series of images shows the progression of a rat reaching for, grasping and then pulling on a handle in the current device set up.

## Client

Our clients are Dr. Radwin and Dr. Barbe. Dr. Radwin works in industrial and Systems Engineering as well as Biomedical Engineering at the University of Wisconsin - Madison. His interest in research deals with injuries that occur in the industrial workplace. Dr. Radwin works with a team at Temple University lead by Dr. Mary Barbe on this project. The research team at Temple University currently houses the rats and runs the investigations.

## Design Specifications

The client requests a device which provides an opposing force to the rat's pull. There will be forces applied to the rats through a linear actuator. Also, reach duration should be able to be changed by the researcher. The opposing force should begin immediately once the rat begins to pull on the handle. The rat must retain it's grasp on the handle for a given amount of time in order to receive it's food (the food should not fall out immediately once the rat pulls on the handle). The threshold reach duration should range from 25 to 250ms (rat should hold on until force threshold is reached).



# Preliminary Designs

## Designs Considered

### Nippon Linear Actuator

This Nippon Linear Actuator, shown in Figure 3, has the ability to provide a continuous force of 1.8 N which is sufficient for our application as the test specimens are able to apply on average 1.5 N. In addition to the favorable force output the Nippon actuator is very compact with a length of 8.5 cm makes it an ideal size to fit into the rat cage. An additional benefit of this option is that it offers a large input range from 10 - 240V can allow for a large degree of adjustability when it comes to varying the speed. The main drawbacks of this option is the price of \$431 and that the company, Nippon, has proven difficult to work with, it took almost two week to be given the price for the actuator.



*Figure 3: S080D linear actuator*

### AMD L12 Linear Servo

Figure 4 shows the AMD L12 Linear Servo. This option offers equivalent force output in both tension and compression, which will be important in our future work for further simulation

of the effect of power tool use. The servo capabilities of the L12 are also an attractive quality as it allows for easy speed control (via pulse width modulation) and allows us to control the exact positioning of the arm based on the voltage we drive into its signal input. . Finally, with a compressed length of 12.5 cm, the L12 will allow for enough room to be left in the cage to be practical. The main drawback of the L12 option is the low maximum speed of 25 mm/s which maybe too low to effectively modulate the intended motion. An additional drawback is that there is a limited range of input voltages (only 4.5 - 7.5V) which will limit the various velocities desired to test different scenarios.



*Figure 4: AMD L12 Linear Servo*

### Firgelli high speed linear actuator

Figure 5 shows the Firgelli high speed linear actuator. This option addresses the speed issues that may be required to effectively simulate the high speeds of power tool operation. This issue however is that this option is large, length of about 25 cm, which make it too large to fit in the space provided without heavy modifications to the cage. In addition to a concern with size the actuator requires an input of 12V of direct current making it unable to adjust the speed of the actuator.



*Figure 5: Firgelli high speed linear actuator*

# Preliminary Design Evaluation

## Design Matrix

Actuator	S120Q Nippon Pulse		AMD L12 Actuator		Firgelli High Speed Actuator	
<b>Adjustability (30)</b>	4/5	24	3/5	18	2/5	12
<b>Cost (25)</b>	1/5	5	4/5	20	3/5	15
<b>Size (25)</b>	5/5	25	4/5	20	1/5	5
<b>Speed(20)</b>	2/5	8	2/5	8	5/5	20
<b>Total (100)</b>	<b>62</b>		<b>66</b>		<b>52</b>	

*Table 1 - Design Matrix:* This design matrix compares 3 possible linear actuators.

## Matrix Criteria

Adjustability is the ability of our design to conform to the range of peak forces and ramp times entered by our client. We weighted adjustability at 30 as it is the most important aspect of our design to our client. We objectively measured adjustability for each linear actuator by comparing the range of voltages over which the linear actuator can operate as this relates to the range of speeds the linear actuator can operate over which allows us to control how much force we apply to the rat. The S120Q had a range from 10-240V and thus proved to be the highest rated in this category.

Cost is important to our design as the components we are considering are very expensive and we need to ensure that the linear actuator we purchase is within our budget as the force sensor and amplifier alone come out to nearly \$800. The L12, while pricy, was the most affordable out of the three actuators.

Size is defined as the ability of the actuator to fit into the dimensions of the space available for us to work in. Because the the total depth, width, and length we have to work with are set parameters we want to minimize the space the linear actuator takes up in order to ensure we have space for the rest of the components of our design. The S120Q won in this category as its fully extended length was the shortest.

Speed is defined as the maximum speed at which the linear actuator can move. This is important to our design as it correlates to the max force we can apply to the rats arm. We can always slow down the actuators speed using pulse width modulation from our microcontroller, however we can not increase the max speed. The Firgelli actuator won in this category with a max speed of 23 cm/s.

## Final Design

According to our matrix evaluation the L12 actuator will be most appropriate to use because it minimizes cost while still providing sufficient adjustability and force.

Based upon our choice of the L12 actuator, we then designed a base that would stabilize it and bring the system up to the height the current system rests at. The line of action of the system needed to be 9.5 cm from the tabletop and needed to fit within the space between the cage and the wall which measured ~ 20 cm. The base would be made out of aluminum and

would support the L12 by the actuator sitting on top of it. The servo would be fixed in position via brackets provided by the manufacturer. Rigid bars between the load cell and actuator and from the load cell to the handle would provide enough support throughout the system. This allows us to use less material in our final design. The dimensions of the base and the final assembly can be seen in Figures 6 & 7 respectively.

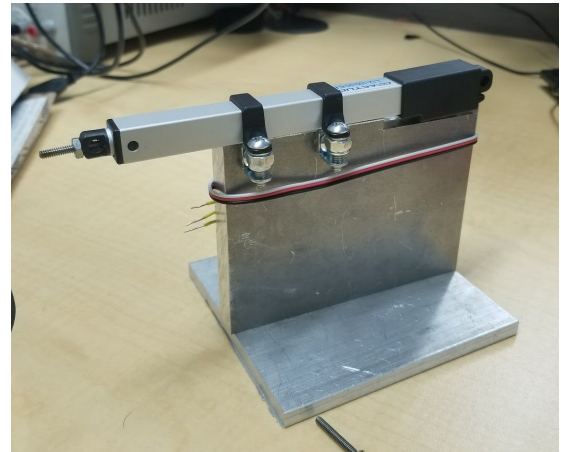
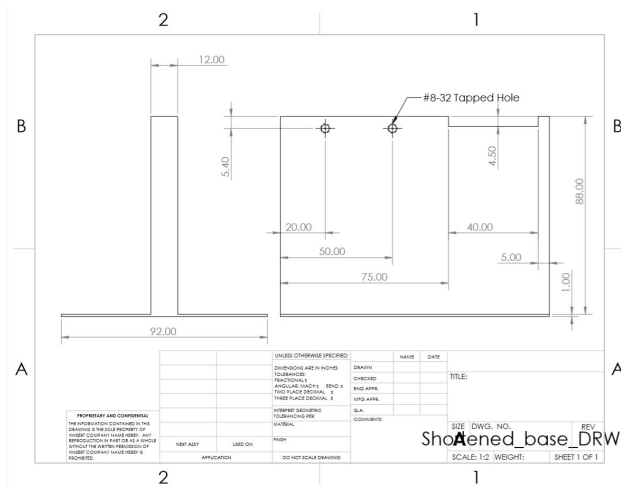

Figure 6: Dimensional Drawing of the base (mm)

Figure 7: Fabricated base assembly with L12

## Fabrication & Development Process

### Materials

Our design will consist of a FUTEK LSB200 load cell as the force sensing element in our design. We will also have a CSG110 amplifier in order to increase the resolution of the signal coming from our sensor as the forces we are working with are very small. The signal coming out of the amplifier will then be sent to an Arduino microcontroller which will process the signal and

determine if the linear actuator needs to be extended or retracted. The microcontroller will control the linear actuator via an H-Bridge circuit by allowing the microcontroller to switch the polarity of the voltage being applied to the L12 linear actuator. The H-Bridge circuit will also prevent excessive current from going through the microcontroller.

## Methods

We will create our final design by following the following simplified procedure. We will first calibrate our force sensor. We will then directly attach our force sensor to the arm of the linear actuator so that the axis of the load on the force sensor would be in line with the axis of the linear actuators arm movement. We will then connect the Linear actuator to the H-Bridge and the force sensor to the amplifier. The H-Bridge will then be connected to a PWM output of the microcontroller and the amplifier to the analog input to complete the circuit.

## Testing

The team began testing with the calibration test. This test consisted of hanging various weights from our load cell as shown in figure 8 below.

*Figure 8. Testing Setup:* Image of testing setup for load cell calibration. Load cell is hanging from the linear actuator and a weight of known value is then hanging from the load cell.



The result of the calibration test will be discussed in the results portion of this report. In addition to the calibration testing, a proof of concept test was conducted. This test consisted of running the program associated with the device and identifying if the code would output a “SUCCESS” if the force read by the load cell surpassed the ramping force threshold, set prior to the commencement of the test, or “FAILURE” if the force dropped sufficiently below the threshold. The proof of concept test was ran multiple times with varying loads to ensure that the results would be consistent.

The final test that was conducted was a durability test in which the device was shaken and flipped upside down as shown in figure 9 to ensure that the device would survive being shipped to Temple University so that our client, Professor Barbe, may implement her own set of tests.

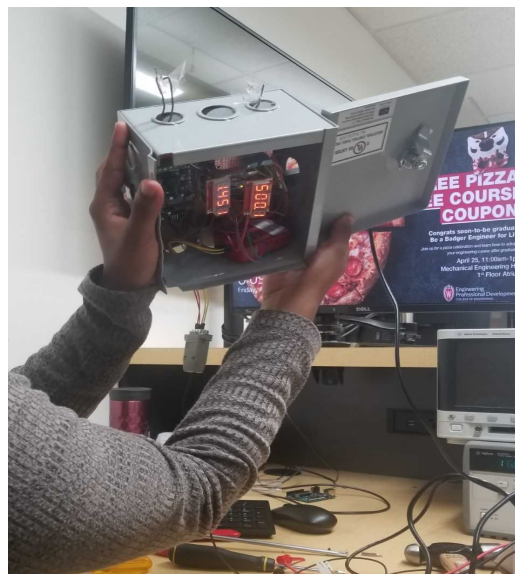

*Figure 9. Image taken during durability test.*

We plan to potentially implement further tests which are described in the testing protocol which is located in **Appendix D**.

## Results

For the calibration test, the calibration curve shown in figure 10 was observed. From this test, the maximum force that could be read by our device was found to be 2.172 N, which ensures that all recorded force values fall below the 5N maximum load of the load cell.

ADC Vs. Force

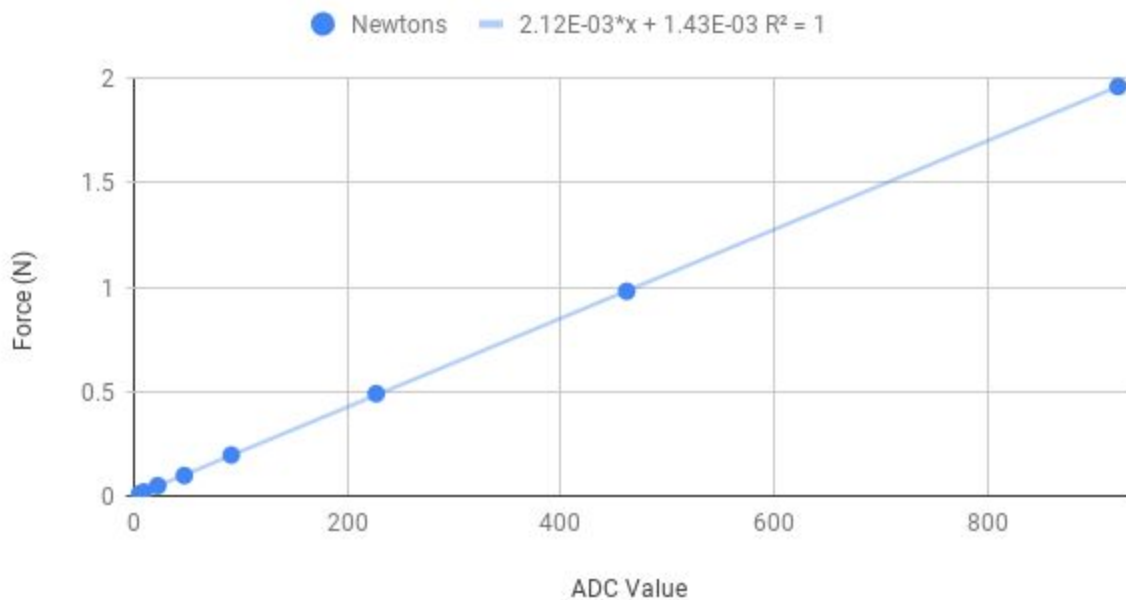

*Figure 10. Graph of the calibration curve obtained from the calibration test:*

Curve was used to calculate maximum recordable load as well as the conversion equation used in the code.

The proof of concept tests resulted in successful determination between tests in which the program should have output “SUCCESS” and tests in which “FAILURE” were to be output. Below figure 11 and figure 12 illustrate a success test and a failure test respectfully. The results of this test allowed for us to be certain that the device is functioning properly.



Trial 1: Successful Pull (Timeframe: 500ms; Max Force: 1.45N)

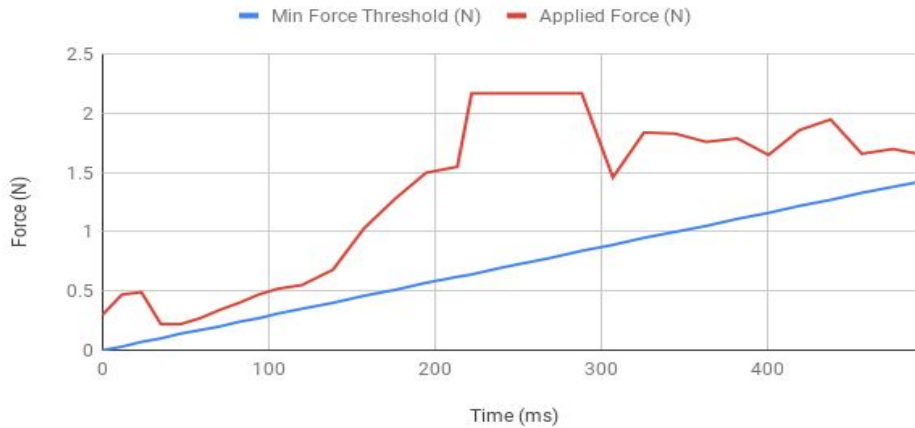

Figure 11. Graph of a test resulting in "SUCCESS":  
Force exceed the threshold for the entire time resulting in a successful test

Trial 5: Unsuccessful Pull (Timeframe: 500ms; Max Force: 1.45 N)

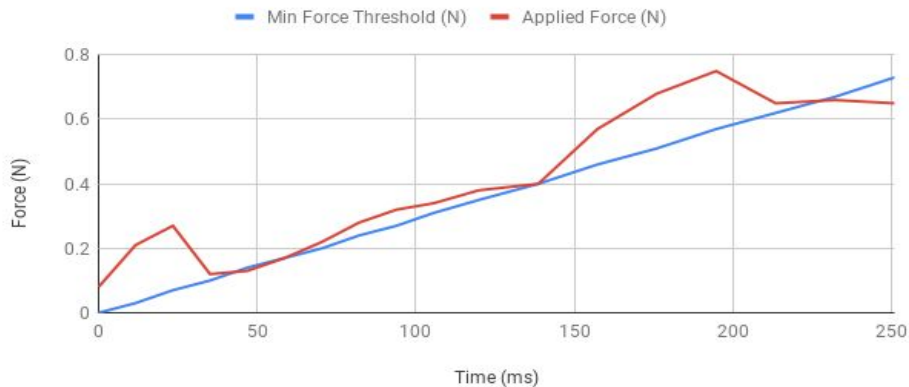

Figure 12. Graph of test resulting in "FAILURE":  
The time scale stops at 250 ms validating the program has recorded the test as a failure

The durability test also resulted in a success. As shown in figure 9, the output of the LED displays showed that the device was still able to function after the abuse that the device had been subjected to. The result from this test validated that the device would be able to safely be shipped and still be able to function as expected.

# Discussion

## Implications

If our design is successful in modeling repetitive motion injuries in rats our clients can then study the effects of these injuries on the rats' muscle tissue. Rats are model organisms for human beings in many aspects of biology and physiology, and by better understanding these injuries in the rats, our client would be able to make connections to the progression of these injuries in humans. This research could eventually lead to a better understanding of the effects and pathways of repetitive motion injuries in the workplace and help to create more comprehensive guidelines for heavy machinery operation.

## Considerations

Some considerations we kept in mind as we progressed in the project were that we needed to ensure that our product met the size requirements set in place by our client, and if we needed to compromise on some aspects of our design, our client needed to know exactly how this could affect her research. Because our clients research has implications on human health, any deviation from what our client expected our product to be capable of compared to what it actually could do could lead to incorrect conclusions being drawn and have an adverse effect on health policies.

# Conclusion

## Findings

Our client is aiming to model repetitive motion injuries in rats. Currently the design our client is using does not apply any force to the rats arm as it is pulling. Our client would like us to create a product which applies a dynamic load to the rats arm which will increase linearly, starting at zero load, over a time period (set by our client) to a peak load (also set by our client). From our previous work on the project we found that the best way to do this is by using a linear actuator controlled by a microcontroller to pull back on the rats arm and apply a force.

Through the course of the semester, the group was able to implement a circuit that would allow for dynamic load testing. The current model utilizes a linear actuator which exceeds the size requirements set in place by our client and thus future work would include implementation of the smaller actuator which was purchased. Some additional findings from the current model were that the group had successfully calibrated the load cell as well as validated the program was able to construct data files which could be copied onto a microsd card and later converted into an excel file for analysis. Additionally, the hardware has been tested to ensure that once the implementation of the smaller load cell is complete the device will likely survive being shipped to Temple University where it can then be used in rat testing and hopefully progress Dr. Barbe's research.

## Future Work

In the future we plan to switch out the PA-15 linear actuator, which we were using as a proof of concept, with the L12 servo. This replacement will involve changes to both hardware and software components. The L12 will need an extra wire input into the arduino as its position is controlled by the magnitude of the signal inputted, unlike the PA-15 which uses changing polarity to control motion. The code will also need to be adjusted accordingly to control the L12. However other than these minor changes the majority of the code will stay the same, and the logic of the code will remain unchanged.

Once the implementation of the L12 is complete a series of tests similar to those described in the testing portion of this report will be conducted to ensure the implementation was successful. After these tests are conducted the device can be shipped to Dr. Barbe where the device can be fitted into her testing setup and tests with the rats can be conducted that will hopefully prove to be useful in progressing her research and eventually lead to the betterment of industry practice and a reduction in musculoskeletal disorders.

## References

- [1] United States Department of Labor, “PREVENTION OF WORK-RELATED MUSCULOSKELETAL DISORDERS,” 2014. [Online]. Available: [https://www.osha.gov/pls/oshaweb/owadisp.show\\_document?p\\_id=4481&p\\_table=UNIFIED\\_AGENDA](https://www.osha.gov/pls/oshaweb/owadisp.show_document?p_id=4481&p_table=UNIFIED_AGENDA). [Accessed: 26-Feb-2019].
- [2] L. Foss et al., “The Impact of Workplace Risk Factors on Long-term Musculoskeletal Sickness Absence,” *J. Occup. Environ. Med.*, vol. 53, no. 12, pp. 1478–1482, Dec. 2011.
- [3] V. S. Massicotte et al., “Prolonged performance of a high repetition low force task induces bone adaptation in young adult rats, but loss in mature rats,” 2015.
- [4] S. A. Hays et al., “The isometric pull task: A novel automated method for quantifying forelimb force generation in rats,” *J. Neurosci. Methods*, vol. 212, pp. 329–337, 2013.
- [5] “Musculoskeletal Disorders: Anatomy of an Injury,” *University of Pittsburgh*, 2007. [Online]. Available: <https://www.ehs.pitt.edu/workplace/musculoskeletal.html>. [Accessed: 02-May-2019].
- [6] Occupational Safety and Health Administration, “Ergonomics.” [Online]. Available: <https://www.osha.gov/SLTC/ergonomics/>. [Accessed: 27-Feb-2019].
- [7] J. O. Green, S. Nagaraja, T. Diab, B. Vidakovic, and R. E. Guldberg, “Age-related changes in human trabecular bone: Relationship between microstructural stress and strain and damage morphology,” 2011.
- [8] B. J. Amorim et al., “Low sensitivity of three-phase bone scintigraphy for the diagnosis of repetitive strain injury,” *Sao Paulo Med. J.*, vol. 124, no. 3, pp. 145–149, 2006.

### Images

Figure 3: [http://www.nipponpulse.com/catalog/parts/search/motors-linear-servo/part\\_id:15](http://www.nipponpulse.com/catalog/parts/search/motors-linear-servo/part_id:15)

Figure 4: <https://www.servocity.com/100-mm-stroke-4-lb-thrust-light-duty-linear-servo>

Figure 5: <https://www.firgelliauto.com/products/high-speed-actuator>

# Appendix A - Preliminary PDS

## Product Design Specification (PDS)

Clients: Prof. Radwin, UW-Madison & Prof. Mary Barbe, Temple University

Advisor: Prof. Colleen Witzenburg

Team: Mengizem Tizale [tizale@wisc.edu](mailto:tizale@wisc.edu) (*Leader*)

Yash Gokhale [ygokhale@wisc.edu](mailto:ygokhale@wisc.edu) (*Communicator*)

Luke Hetue [hetue2@wisc.edu](mailto:hetue2@wisc.edu) (*BWIG*)

Carlos Veguilla [cveguilla@wisc.edu](mailto:cveguilla@wisc.edu) (*BPAG & BSAC*)

Date: February 07, 2019

### **Function**

Power hand tool operation in factories and service facilities, including threaded fastener tools (i.e. screwdrivers and nut drivers), present hazardous hand loads resulting in repetitive motion injuries. The rapidly rising impulse loads transmitted to the hands while operating tools often produce stressful eccentric muscle contractions, which exceed the operator's capacity to hold the tool stationary and stretch muscle fibers and tendons, resulting in chronic injuries due to repetitive loading. The objective of this research is to conduct animal studies leading to an understanding of the pathophysiology associated with repetitive tool operation.

This project proposes to develop a device that contains a handle that a rat can be trained to pull which initiates a controlled rapid impulse force in the opposite direction that results in eccentric muscle contractions in the rat's arms, simulating repetitive power hand tool operation. The investigators intend to

train rats to repetitively pull on the handle using sufficient force to activate a motor that then pulls the rat's limb in the opposite direction in order to receive a food pellet. The device will need to fit inside a cage-mounted device of similar dimensions that currently controls passive pull force. The force provided must be enough to strain the rat, but not to exceed the load that it can bear.

### **Client Requirements**

- A device which provides an opposing force to the rat's pull
- Force and reach duration thresholds should be adjustable
- Opposing force should begin immediately once the rat begins to pull on the handle
- The rat must retain its grasp on the handle for a given amount of time in order to receive its food (the food should not fall out immediately once the rat pulls on the handle).
  - Threshold reach duration from 25 to 250ms (rat should hold on until force threshold is reached)
- Force applied to the rat should be around the target 1.44 N (the average force of a rat's pull)

### **Design Requirements**

#### **1. Physical Characteristics**

##### a. Performance Requirements

##### i. Dimensions/Data

1. Distance from window to handlebar: 1.5cm
2. Mean Max Grip Force: 163 gf
3. Threshold Force:  $0.15(163) = 24.45\text{gf}$
4. Mean Reach Force(from data) = 146.75gf or 1.439N
5. Mean Reach Duration(from data) = 0.1463sec





- i. The experiment will be run over 6-12 weeks and the device should last for multiple trials

e. Shelf Life

- i. The apparatus should be stored at approximately 25 degrees Celsius.
- ii. The apparatus should be able to last at least three years on the shelf while maintaining functionality

f. Operating Environment

- i. The materials used will be put under stress by the pull of the rat. This is not a very significant amount of force (about 1.5 Newtons), but it will stress materials over a long amount of time. While the experiment is only being run for 6-12 weeks, preferably the device will be able to last for longer than that, in case it is needed for further research. The lab could become humid during the summer months, however the device will likely always be operating at room temperature plus or minus a few degrees celsius. Dirt and dust could certainly collect, so the device should be cleaned twice weekly to avoid this causing issues it's functioning.

g. Ergonomics

- i. The handle must be small enough to be gripped by a rat. It must be strong enough to not become weak or deformed under the force of the rat pulling on it. The handle needs to be located approximately 8.5 cm above the level of the rat (in order to fit the current model), and it must be located about 1.5 cm from the hole that the rat has to reach through. The

force applied in reaction to the rat's pull should not exceed 2.5 N in the case that this could instantaneously injure the rat.

h. Size

i. The product must be able to fit within the rest of the current model. The box that rats are held in is 31.8 cm tall. The handle is 8.5 cm from the bottom of the box.

i. Weight

i. Once our product is installed to the rest of the machine, it will not move. That being said, it needs to be light enough to be handled by the average person (50 lbs). Apart from that, there are no weight limitations.

j. Materials

i. The PA-15 Linear Actuator was used to create a linear reaction force. 2 p and 2 n channel mosfet transistors, 2 npn transistors, 4 10k Ohm resistors, and 2 2k Ohm resistors were used in the circuitry for the device. A force sensor was used to detect the pull of the rat. The force sensor was required to pick up forces between 0 and 5 N due to the small forces of the rat.

k. Aesthetics, Appearance, and Finish

i. Because it is being used to research with rats, the functionality is the only concern for our product. Appearance is not important.

## 2. Production Characteristics

a. Quantity

- i. One device to be built
- b. Target Product Cost
  - i. It should cost less than the Vulintus Mototrak which costs \$3520. Our client did not specify a certain budget, but would like the product to be produced for under \$500.

### **3. Miscellaneous**

- a. Standards and Specifications
  - i. Because we are building this for the specific use of a client, and not a marketable product, there are no formalized standards; FDA approval is not needed.
- b. Client
  - i. Our client, Professor Radwin, wants to incorporate a linear actuator in our design.
- c. Patient-related Concerns
  - i. Because the device is technically being used by rats each day, there are no patient-related concerns.
- d. Competition
  - i. The Vulintus Mototrak is very similar to the product we are developing. However, it features a static handle, not a dynamic handle.

## Appendix B List of Materials

Item	Manufacturer	Part Number	QTY	Cost Each	Total	Link
<b>Acuator</b>						
100 mm Stroke 4 lb Thrust Light Duty Linear Servo	Acuonix	L12-R-100-50-6	1	69.99	\$69.99	<a href="https://www.servocity.com/100-mm-stroke-4-lb-thrust-light-duty-linear-servo">https://www.servocity.com/100-mm-stroke-4-lb-thrust-light-duty-linear-servo</a>
<b>Load Cell</b>						
FUTEK LSB200	Futek	FSH02602	1	500	\$500.00	<a href="http://www.futek.com/product.aspx?stock=FSH02602#productDescription">http://www.futek.com/product.aspx?stock=FSH02602#productDescription</a>
<b>SD cards/reader</b>						
SenMod 5PCS Micro SD Card Micro SDHC Mini TF Card Adapter Reader Module for Arduino	SenMod	2126efef26m206	1	8.29	\$8.29	<a href="https://www.amazon.com/SenMod-Adapter-Reader-Module-Arduino/dp/B01JYNEX56/ref=sxbs_sxwds-stvp?keywords=6+pin+micro+sd+card+reader&amp;pd_rd_i=B01JYNEX56&amp;pd_rd_r=f1ef0f19-6a27-4da8-88f6-050b6340c03b&amp;pd_rd_w=XG6Ru&amp;pd_rd_wg=jVN9d&amp;pf_rd_p=5c5ea0d7-2437-4d8a-88a7-ea6f32aeac11&amp;pf_rd_r=NFT3MBGAM1WDF8QC3VNS&amp;qid=1554044772&amp;s=electronics">https://www.amazon.com/SenMod-Adapter-Reader-Module-Arduino/dp/B01JYNEX56/ref=sxbs_sxwds-stvp?keywords=6+pin+micro+sd+card+reader&amp;pd_rd_i=B01JYNEX56&amp;pd_rd_r=f1ef0f19-6a27-4da8-88f6-050b6340c03b&amp;pd_rd_w=XG6Ru&amp;pd_rd_wg=jVN9d&amp;pf_rd_p=5c5ea0d7-2437-4d8a-88a7-ea6f32aeac11&amp;pf_rd_r=NFT3MBGAM1WDF8QC3VNS&amp;qid=1554044772&amp;s=electronics</a>
<b>Amplifier</b>						
Analog Amplifier with Voltage Output	Futek	FSH03863	1	425	\$425.00	<a href="http://www.futek.com/product.aspx?stock=FSH03863">http://www.futek.com/product.aspx?stock=FSH03863</a>
<b>H-Bridges</b>						
DC Brush Motor Controller	DROK	2001712008	1	18.99	\$18.99	<a href="https://www.amazon.com/Controller-DROK-H-Bridge-Brushed-Regulator/dp/B078TFLD7Q?ref_=fscpl_dp_4&amp;th=1">https://www.amazon.com/Controller-DROK-H-Bridge-Brushed-Regulator/dp/B078TFLD7Q?ref_=fscpl_dp_4&amp;th=1</a>
<b>Fuses</b>						

10pcs 5x20mm Fuse Holder Inline Screw Type With 18 AWG wire + 150pcs Quick Blow Glass Tube Fuse Assorted Kit	Lime 2018	B07F8RLMP B	1	11.99	\$11.99	<a href="https://www.amazon.com/5x20mm-Holder-Inline-150pcs-Assorted/dp/B07F8RLMPB/ref=sr_1_9?keywords=glass+tube+fuses&amp;qid=1554396335&amp;s=gateway&amp;sr=8-9">https://www.amazon.com/5x20mm-Holder-Inline-150pcs-Assorted/dp/B07F8RLMPB/ref=sr_1_9?keywords=glass+tube+fuses&amp;qid=1554396335&amp;s=gateway&amp;sr=8-9</a>
Rocker Switch	Karlsson Robotics	COM-11138	1	0.5	\$0.50	<a href="https://www.kr4.us/rocker-switch-spst-round.html?gclid=EAJaIQobChMI9NKo3vK24QIVkksNCh004g4qEAkYBSABEGk4EfD_BwE">https://www.kr4.us/rocker-switch-spst-round.html?gclid=EAJaIQobChMI9NKo3vK24QIVkksNCh004g4qEAkYBSABEGk4EfD_BwE</a>
<b>Circuit Box (houses the circuit making it look nicer as well as minimizing damage that could occur while storing or transport)</b>						
JBH-4955-KO	Bub industries	JBH-4955-K O	1	15.3	\$15.30	<a href="https://www.mouser.com/ProductDetail/Bud-Industries/JBH-4955-KO?qs=JBUb7fVvPpITA0cXEsaXw%3D%3D&amp;gclid=EAJaIQobChMIeKHols54QIVFP7jBx2xMgFEEAkYAiABEGKw9vD_BwE">https://www.mouser.com/ProductDetail/Bud-Industries/JBH-4955-KO?qs=JBUb7fVvPpITA0cXEsaXw%3D%3D&amp;gclid=EAJaIQobChMIeKHols54QIVFP7jBx2xMgFEEAkYAiABEGKw9vD_BwE</a>
<b>Perf boards (used to construct circuit on to minimize wiring)</b>						
FTCBlock 32 Pcs Double Sided PCB Board Prototype Kit for DIY Soldering with 5 Different Sizes Compatible with Arduino	FTCBlock	B07FYD8ZF S	1	8.45	\$8.45	<a href="https://www.amazon.com/FTCBlock-Prototype-Soldering-Different-Compatible/dp/B07FYD8ZFS/ref=sr_1_6?keywords=perf+boards&amp;qid=1554398517&amp;refinements=p_36%3A-1000&amp;rnid=1243644011&amp;s=hi&amp;sr=1-6">https://www.amazon.com/FTCBlock-Prototype-Soldering-Different-Compatible/dp/B07FYD8ZFS/ref=sr_1_6?keywords=perf+boards&amp;qid=1554398517&amp;refinements=p_36%3A-1000&amp;rnid=1243644011&amp;s=hi&amp;sr=1-6</a>
<b>Wall Plug (to power system)</b>						
VSEER 6ft 18 Gauge 3 Prong Heavy Duty Universal AC Appliance Replacement Power Supply Cord Cable Kit	VSEER	B07KN7MN 9C	1	7.99	\$7.99	<a href="https://www.amazon.com/Universal-Appliance-Replacement-Supply-Pigtail/dp/B07KN7MN9C/ref=sr_1_14?crid=2NQZZ73ODMLFV&amp;keywords=power%2Bcord%2Bopen%2Bend&amp;qid=1554475352&amp;s=gateway&amp;prefix=power%2Bcord%2Bope%2Caps%2C160&amp;sr=8-14&amp;th=1">https://www.amazon.com/Universal-Appliance-Replacement-Supply-Pigtail/dp/B07KN7MN9C/ref=sr_1_14?crid=2NQZZ73ODMLFV&amp;keywords=power%2Bcord%2Bopen%2Bend&amp;qid=1554475352&amp;s=gateway&amp;prefix=power%2Bcord%2Bope%2Caps%2C160&amp;sr=8-14&amp;th=1</a>
VTX-214-001-318 -	Virgortonix	<a href="#">VTX-214-001-318</a>	1	27.53	\$27.53	<a href="https://www.newark.com/vigortronix/vtx-214-001-318/power-supply-ac-dc-18v-0-055a/dp/31AC2640?st=18V%20modular%20power%20supply">https://www.newark.com/vigortronix/vtx-214-001-318/power-supply-ac-dc-18v-0-055a/dp/31AC2640?st=18V%20modular%20power%20supply</a>
<b>Mount material</b>						

Aluminum plate	Grainger	<a href="#">Alloy 6061</a>	1	33.3	\$33.30	<a href="https://www.grainger.com/category/raw-materials/aluminum/aluminum-bars-plates-and-sheet-stock">https://www.grainger.com/category/raw-materials/aluminum/aluminum-bars-plates-and-sheet-stock</a>
<b>7-segment LED display</b>						
uxcell 5 Pcs Common Cathode 12 Terminals 4 Bit 7 Segment 0.36" Red LED Display Digital Tube	uxcell	3461AH	1	3.82	\$3.82	<a href="https://www.amazon.com/uxcell-Cathode-Terminals-Segment-Display/dp/B00EZBDOGM/ref=sr_1_24?crid=S1T964WYGFXD&amp;keywords=7%2Bsegment%2Bled%2Bdisplay&amp;qid=1554650013&amp;s=gateway&amp;sprefix=7%2Bsegment%2B%2Caps%2C141&amp;sr=8-24&amp;th=1">https://www.amazon.com/uxcell-Cathode-Terminals-Segment-Display/dp/B00EZBDOGM/ref=sr_1_24?crid=S1T964WYGFXD&amp;keywords=7%2Bsegment%2Bled%2Bdisplay&amp;qid=1554650013&amp;s=gateway&amp;sprefix=7%2Bsegment%2B%2Caps%2C141&amp;sr=8-24&amp;th=1</a>
<b>Total</b>					<b>\$1131.15</b>	

## Appendix C Circuitry

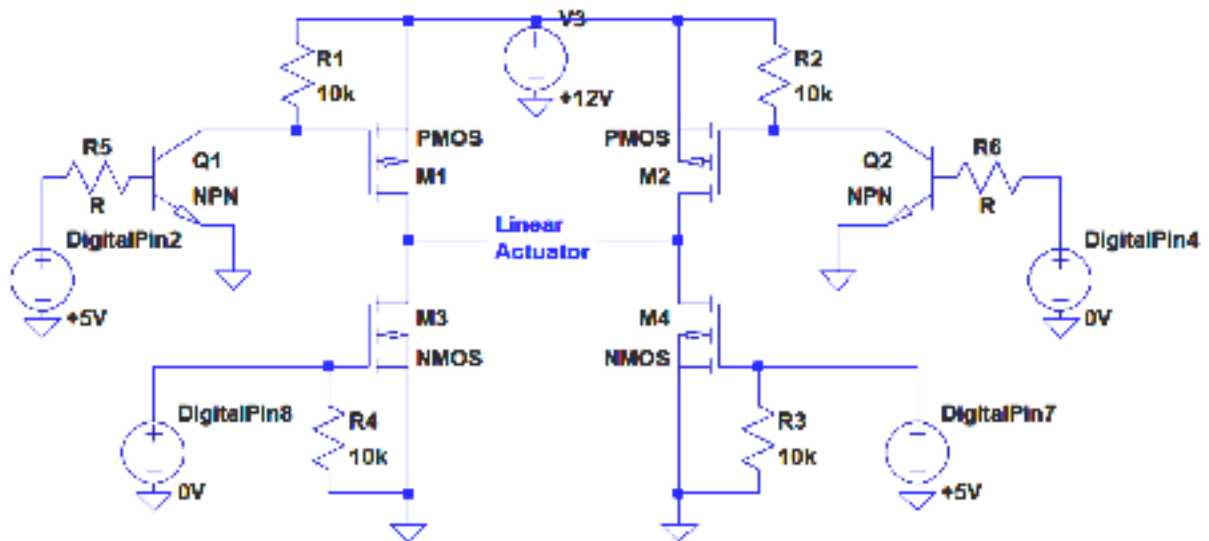

H-Bridge Circuit Simulation (LT-Spice)

# Appendix D Testing Protocol

## Testing Protocol

1. Finding the appropriate spring to model a rats arm.
  - a. The target will be to find a spring that when stretched to a distance of 1 cm provides a force of 2 N ( $k_s = 200$ )
  - b. To find a suitable spring:
    - i. The initial lengths of various springs will be obtained in m.
    - ii. The mass of different weights will be recorded and then hung from the springs and the final length will be recorded.
    - iii. Using the equation  $k_s = (m \cdot g) / (l_f - l_0)$  the spring constants will be solved for each weight/ spring combination and the average for each spring will be obtained.
    - iv. The spring whose spring constant is the closest to 200 will be selected.
2. Calibration of circuit with chosen spring
  - a. Using the best spring from test 1, we plan to connect attached the circuit and spring system to a fixed object and then have the system stretch the spring to various lengths on the order of 0.5 cm increments to a maximum length of 2.5 cm where the Analog to Digital Converter (ADC) value being read by the sensor will be recorded. These ADC values will be compared to the expected force values, which will be calculated using the equation  $F_s = k_s \cdot \Delta x$ . A plot of force vs. ADC value will be created and a line of best fit will be obtained and than used as a conversion factor in the code to display force.
3. Failure testing
  - a. This test will validate the circuit is responding to extreme threshold force values.
    - i. Excessive load
      1. Using a similar set up to the calibration test, the spring will be stretch to a length were the load will exceed the cutoff threshold of 4N, which is below the maximum load of 5 N which the load cell is meant to measure.
      2. The expected outcome of the high force value is the actuator will stop resisting and the test terminates.
    - ii. Below threshold load
      1. Using a similar set up to the calibration test, the spring will be stretch to a length that is above the acceptable force threshold, which will be varied to ensure this test holds at any test criteria.
      2. The spring will then be shortened to reduce the load quickly to simulate the drop in force if the rat stops pulling on the handle.
      3. The expected outcome would be the actuator to stop resisting any force and the test to be terminated.