

# CLIMBER'S FOREARM TRAINER



Team Members: Brittany Glaeser, Kaitlin Lacy, Marissa Harkness, Zoe Schmanski, Jonathon Murphy  
 Client: Dr. Chris Vandivort  
 Advisor: Dr. John Puccinelli



College of Engineering  
 UNIVERSITY OF WISCONSIN-MADISON

College of Engineering  
 UNIVERSITY OF WISCONSIN-MADISON

## Abstract

"Climber's Elbow" is a condition experienced by many climbers where the tendon between the forearm flexors and medial epicondyle of the elbow develops microtears. The Forearm Trainer was designed to aid in prevention and rehabilitation of Climber's Elbow. The device includes variable resistances and a grip strengthener handle. The portable device strengthens the flexors and extensors as well as pronators and supinators of the forearm.

## Motivation

Climber's Elbow, also known as Medial Epicondylitis, affects many rock climbers and can be treated through resistance training of the forearm flexors and extensors. A portable device can help aid in the prevention and rehabilitation of this condition.

## Background

- 4 major forearm muscles [1]
- Pronator teres is the muscle of focus
- Movements:
  - Pronation of hand
  - Flexing of the elbow
- Medial Epicondylitis / "Climber's Elbow"
  - Micro-tearing of the pronator teres [2]
  - overuse of the tendon without sufficient recovery
  - Imbalance in strength of flexor muscles versus the extensor muscles = excessive strain [3]

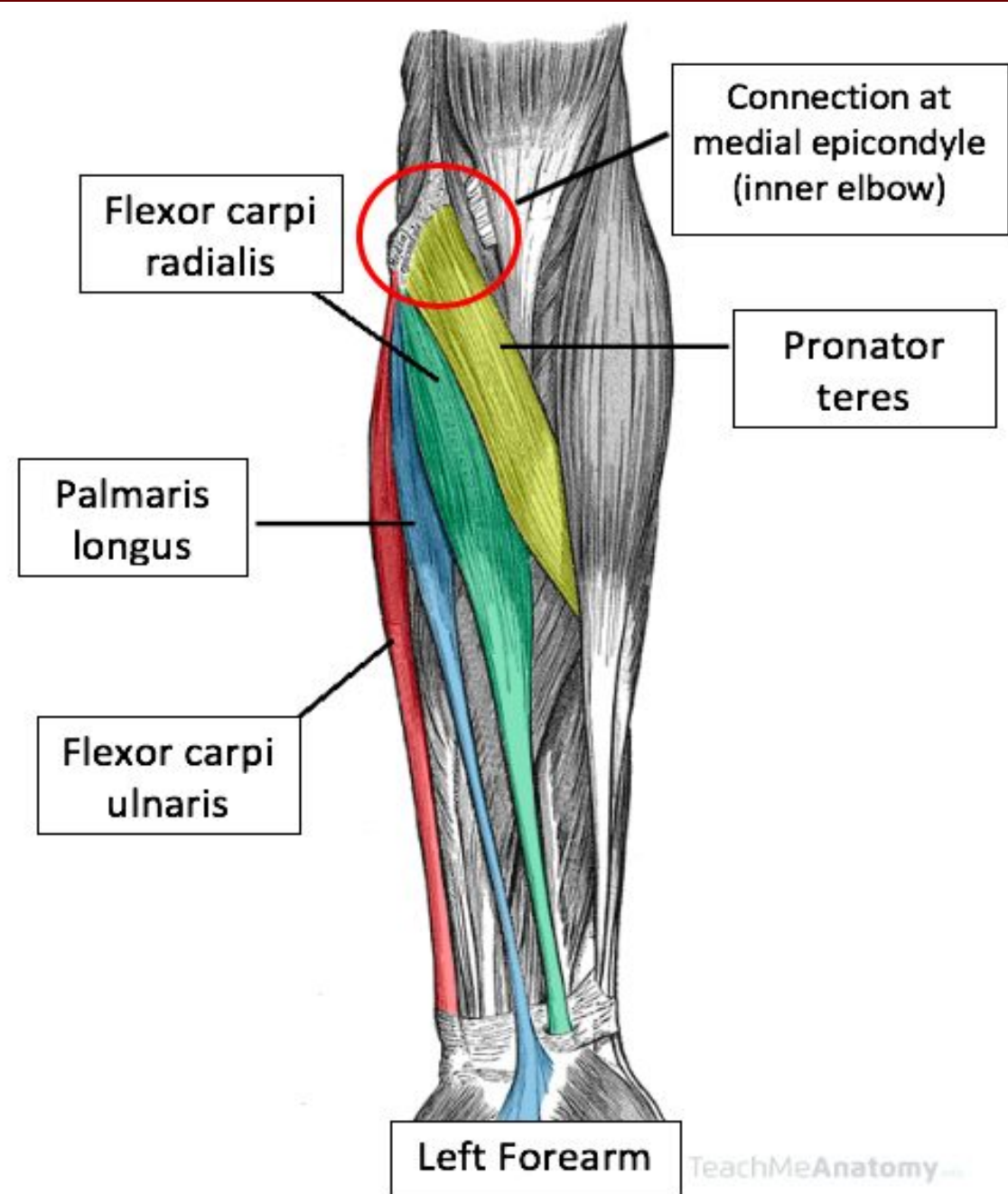

Figure 1: The 4 main muscle groups attached at the medial epicondyle [4]

### Current Devices



Figure 2: Hangboard [5]

Figure 3: Vive Health Finger Exerciser [7]

Figure 4: Handmaster Plus [6]

## Design Criteria

- Effectively targets forearm muscles
- Variable resistances of 5-30 lbs
  - Average forearm length of 23.1 - 26.4 cm
  - Average upper arm length of 29.2 - 33.4 cm [8]
- Durable to withstand daily use for many years
  - Five to ten years for plastic pieces and straps
- Includes grip strengthening component
- Follows ASTM Standards of Fitness [9]
- Easy to use, safe, comfortable, portable and low cost

## Materials

- 3D print - PLA
- Rollerblade straps
- Sponge foam padding
- Flex seal
- Resistance bands
- Carabiners
- 1" Nylon straps
- Hook eye screws
- 0.25" Eyelets
- Brass knurled inserts

Total Costs: \$120.93

## Testing and Results

### FEA of Base Design

- Base design will withstand the stress of the bands
- Maximum deflection of 2.86 mm

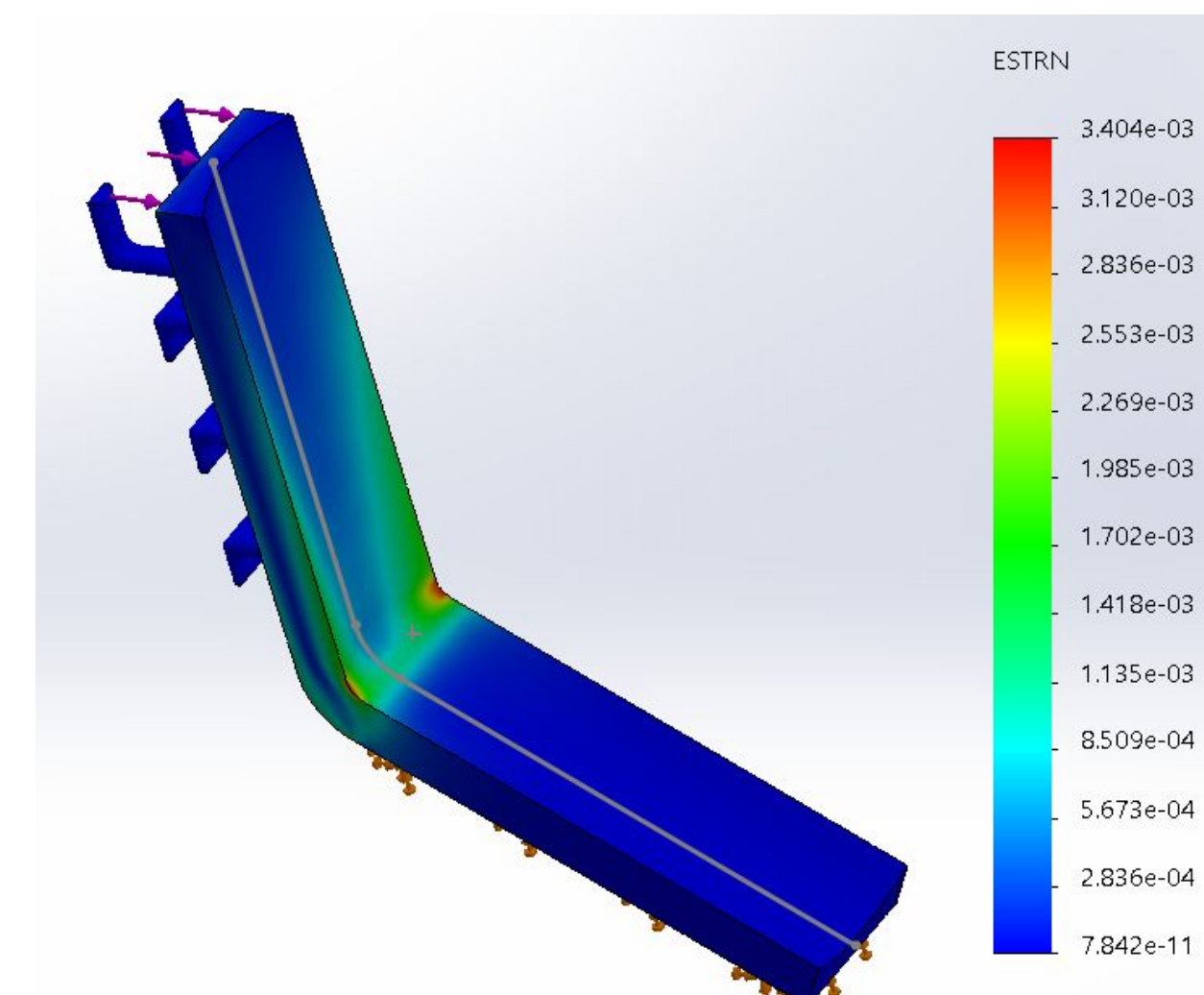

Figure 5: Strain representation of base design under resistance band load

### FEA of Handle Design

- Handle design will withstand the stress of the bands
- Maximum deflection of  $3.57 \times 10^{-4}$  mm.

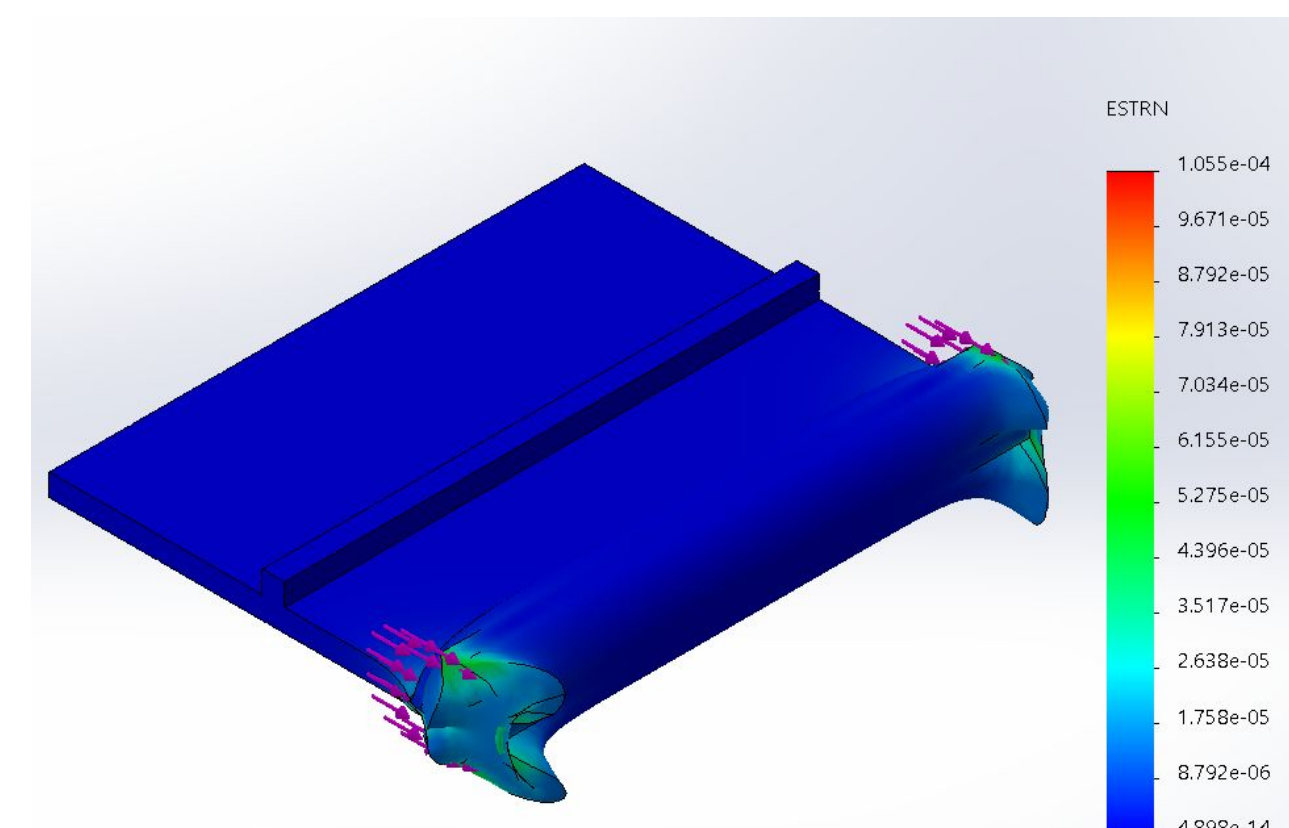

Figure 6: Strain representation of handle design under resistance band load

### Conclusion

- Full design has the ability to withstand the force exerted by the bands.

## Final Design



Figure 7: Original design with updated resistance bands

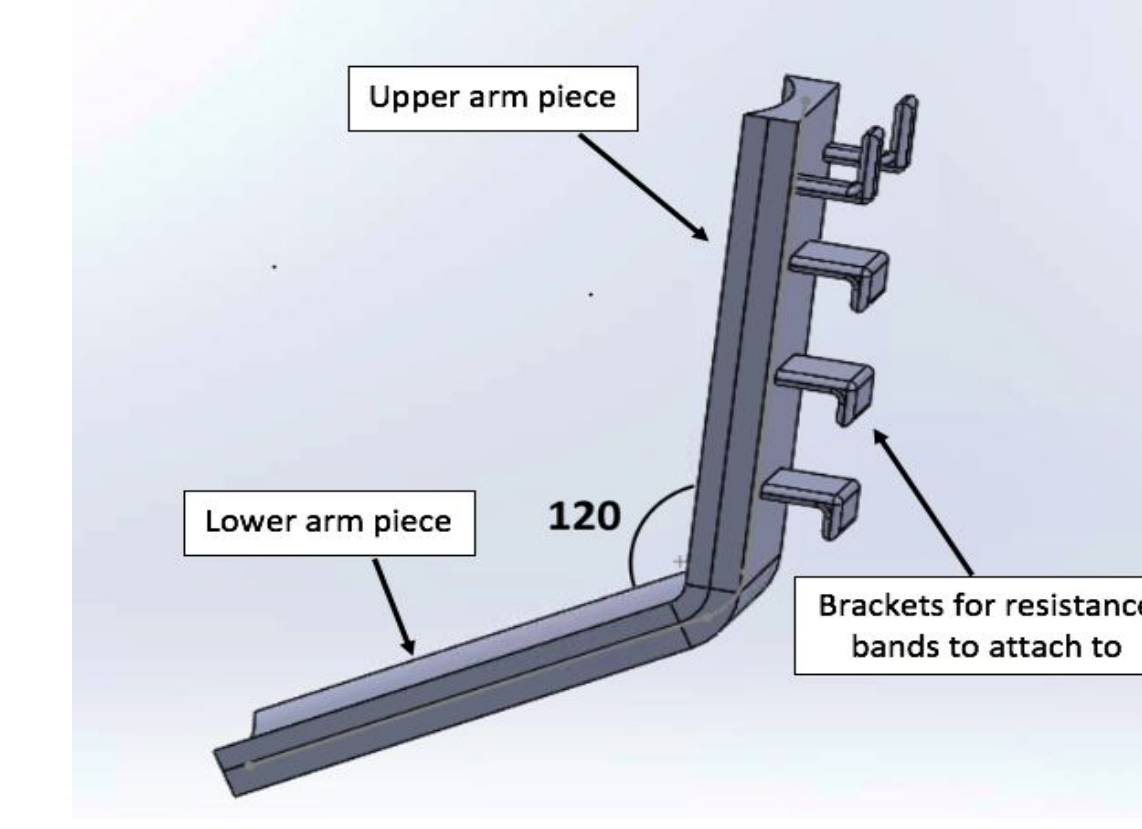

Figure 8: Proposed design of back piece

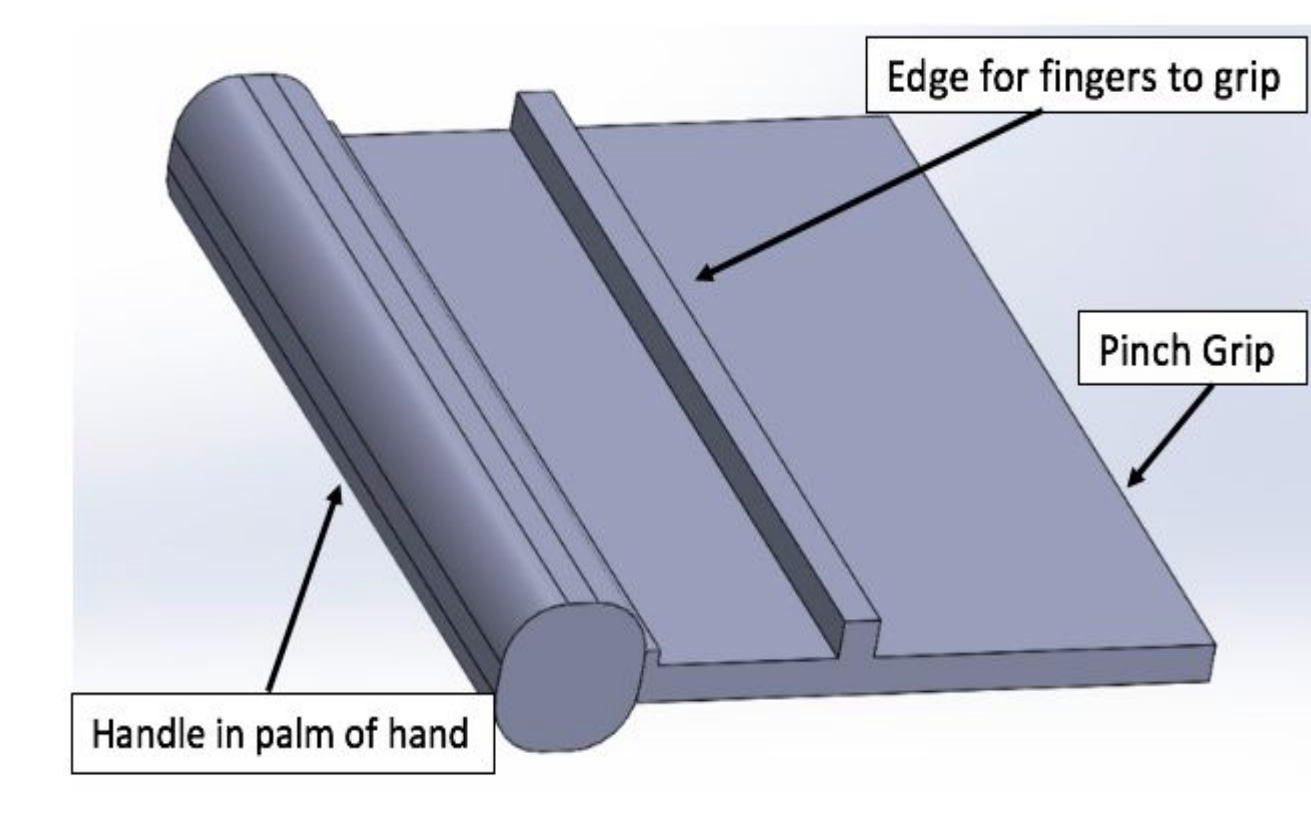

Figure 9: Proposed handle design for grip strengthening

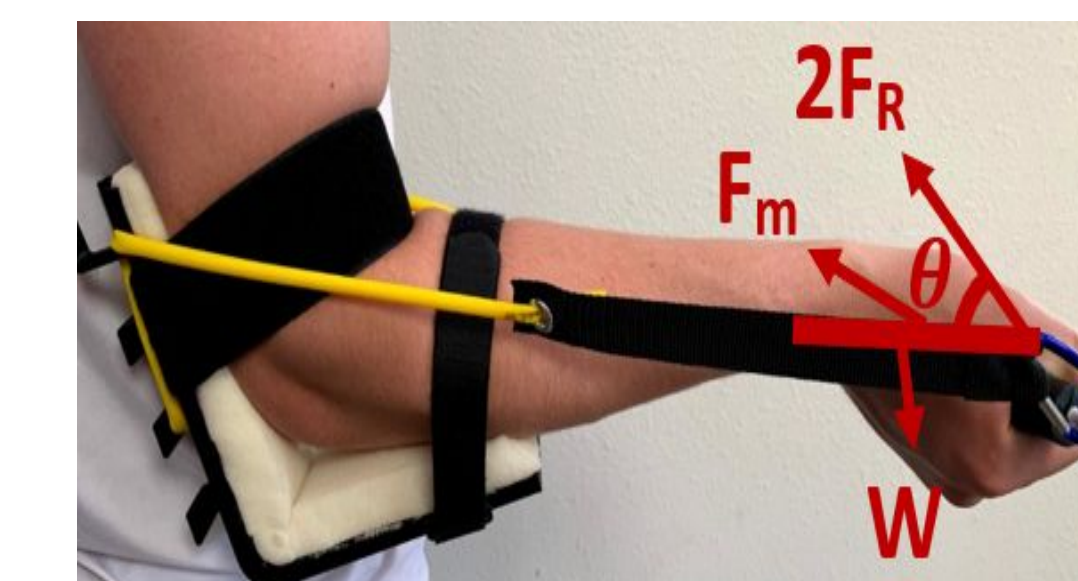

Figure 10: FBD for the extensors and flexors

$$F_m = \frac{L \cdot 2F_R \sin \theta - W \cdot d_w}{MA}$$

$$F_m = \frac{2F_R \sin \theta}{MA}$$

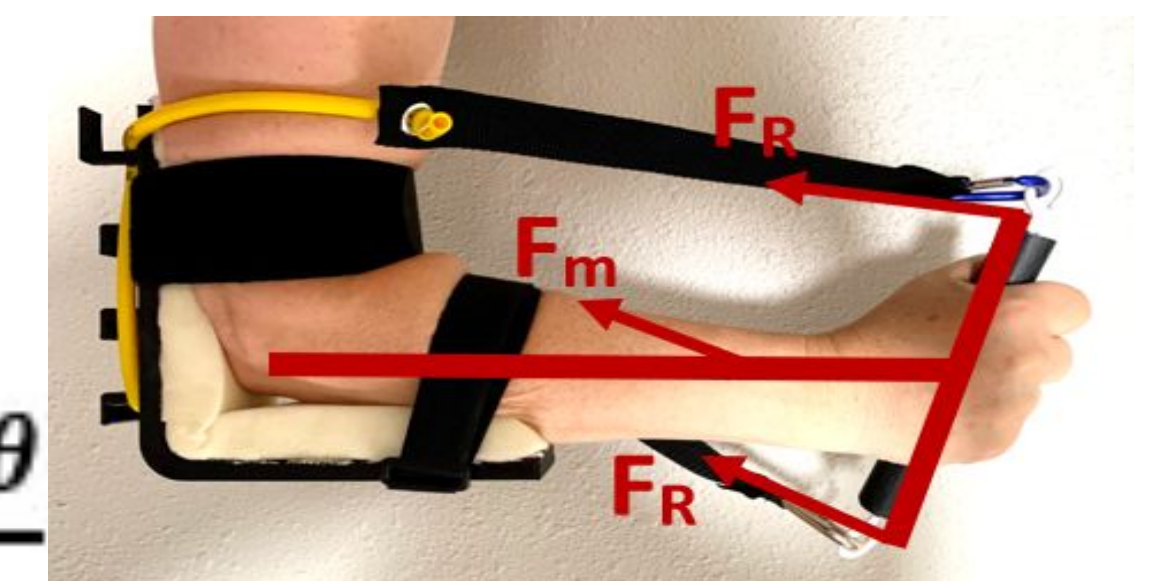

Figure 11: FBD for the pronator teres



Figure 12: Forearm motions used with the device. Shown is the original design with updated resistance bands.

## Future Work

- Tightening mechanism for straps
  - A tension lock similar to those on backpack
- Injection Molding
  - Considered as a mode of fabrication for final prototype after CAD designs are finalized
  - Protolabs Manufacturing
- Removable pinch grip feature
- Testing
  - EMG to confirm isolation of forearm muscles from bicep
  - MTS testing of resistance tubes
  - Usability survey

## Acknowledgements

We would like to thank the following for making this project possible:

- Dr. Chris Vandivort
- Dr. John Puccinelli
- Dr. Christa Wille
- UW-Madison BME Faculty and Staff

## References

- E. Davis, PhD, private communication, Sept. 2019.
- Andros, J. (2019). How to Prevent and Treat Rock Climber's Elbow. [online] Mojo Gear. Available at: <https://mojogear.com/journal/2014/04/01/got-elbows-a-guide-to-coping-with-climbers-elbow/> [Accessed 7 Sep. 2019].
- Edwards, A. and Evans, K. (2019). Stretches to Avoid Elbow Pain from Climbing - Gripped Magazine. [online] Gripped Magazine.
- TeachMe Series, Left Forearm. 2020.
- Vive Health. 2020.
- Handmaster Plus, Handmaster Plus. 2020 a.
- Vive Health, Finger Exerciser. 2020.
- DNQDJ. (2019). Height Percentile Calculator by Gender (United States). [online]. Available at: <https://www.dnqdj.com/height-percentile-calculator-for-men-and-women/> [Accessed 8 Oct. 2019].
- ASTM F2276 - 10(2015). ASTM International - Standards Worldwide. 2015. [Online]. Available: <https://www.astm.org/Standards/F2276.htm> [Accessed: 18-Sep-2019].

# CLIMBER'S FOREARM TRAINER



College of Engineering  
UNIVERSITY OF WISCONSIN-MADISON

Team Members: Brittany Glaeser, Kaitlin Lacy, Marissa Harkness, Zoe Schmanski, Jonathon Murphy

Client: Dr. Chris Vandivort

Advisor: Dr. John Puccinelli



College of Engineering  
UNIVERSITY OF WISCONSIN-MADISON



# CLIMBER'S FOREARM TRAINER

## Motivation

Climber's Elbow, also known as Medial Epicondylitis, affects many rock climbers and can be treated through resistance training of the forearm flexors and extensors. A portable device can help aid in the prevention and rehabilitation of this condition.



# CLIMBER'S FOREARM TRAINER



Team Members: Brittany Glaeser, Kaitlin Lacy, Marissa Harkness, Zoe Schmanski, Jonathon Murphy  
 Client: Dr. Chris Vandivort  
 Advisor: Dr. John Puccinelli



College of Engineering  
 UNIVERSITY OF WISCONSIN-MADISON

College of Engineering  
 UNIVERSITY OF WISCONSIN-MADISON

## Abstract

"Climber's Elbow" is a condition experienced by many climbers where the tendon between the forearm flexors and medial epicondyle of the elbow develops microtears. The Forearm Trainer was designed to aid in prevention and rehabilitation of Climber's Elbow. The device includes variable resistances and a grip strengthener handle. The portable device strengthens the flexors and extensors as well as pronators and supinators of the forearm.

## Motivation

Climber's Elbow, also known as Medial Epicondylitis, affects many rock climbers and can be treated through resistance training of the forearm flexors and extensors. A portable device can help aid in the prevention and rehabilitation of this condition.

## Background

- 4 major forearm muscles [1]
- Pronator teres is the muscle of focus
- Movements:
  - Pronation of hand
  - Flexing of the elbow
- Medial Epicondylitis / "Climber's Elbow"
  - Micro-tearing of the pronator teres [2]
  - overuse of the tendon without sufficient recovery
  - Imbalance in strength of flexor muscles versus the extensor muscles = excessive strain [3]

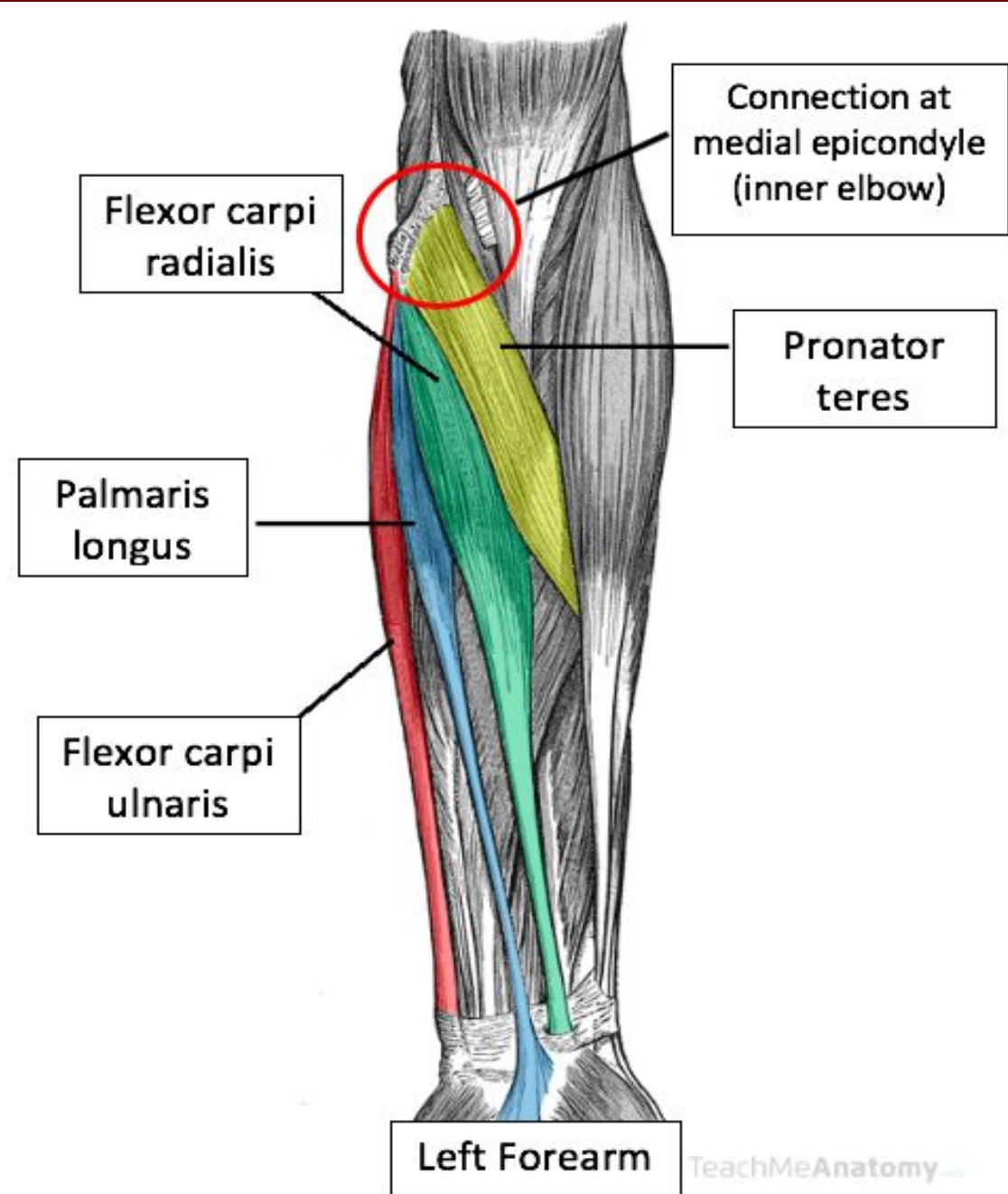

Figure 1: The 4 main muscle groups attached at the medial epicondyle [4]

### Current Devices



Figure 2: Hangboard [5]

Figure 3: Vive Health Finger Exerciser [7]

Figure 4: Handmaster Plus [6]

## Design Criteria

- Effectively targets forearm muscles
- Variable resistances of 5-30 lbs
  - Average forearm length of 23.1 - 26.4 cm
  - Average upper arm length of 29.2 - 33.4 cm [8]
- Durable to withstand daily use for many years
  - Five to ten years for plastic pieces and straps
- Includes grip strengthening component
- Follows ASTM Standards of Fitness [9]
- Easy to use, safe, comfortable, portable and low cost

## Materials

- 3D print - PLA
- Rollerblade straps
- Sponge foam padding
- Flex seal
- Resistance bands
- Carabiners
- 1" Nylon straps
- Hook eye screws
- 0.25" Eyelets
- Brass knurled inserts

Total Costs: \$120.93

## Testing and Results

### FEA of Base Design

- Base design will withstand the stress of the bands
- Maximum deflection of 2.86 mm

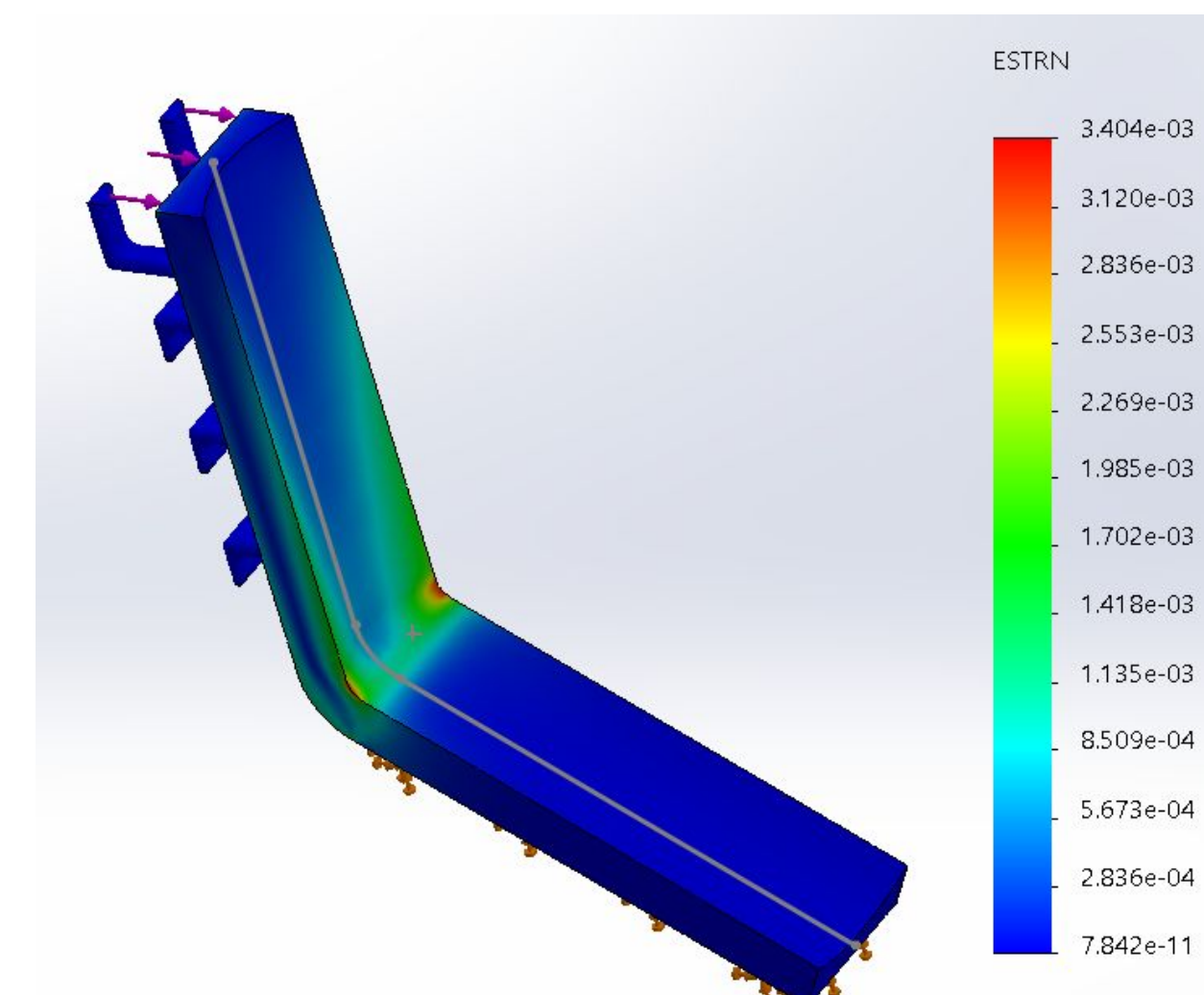

Figure 5: Strain representation of base design under resistance band load

### FEA of Handle Design

- Handle design will withstand the stress of the bands
- Maximum deflection of  $3.57 \times 10^{-4}$  mm.

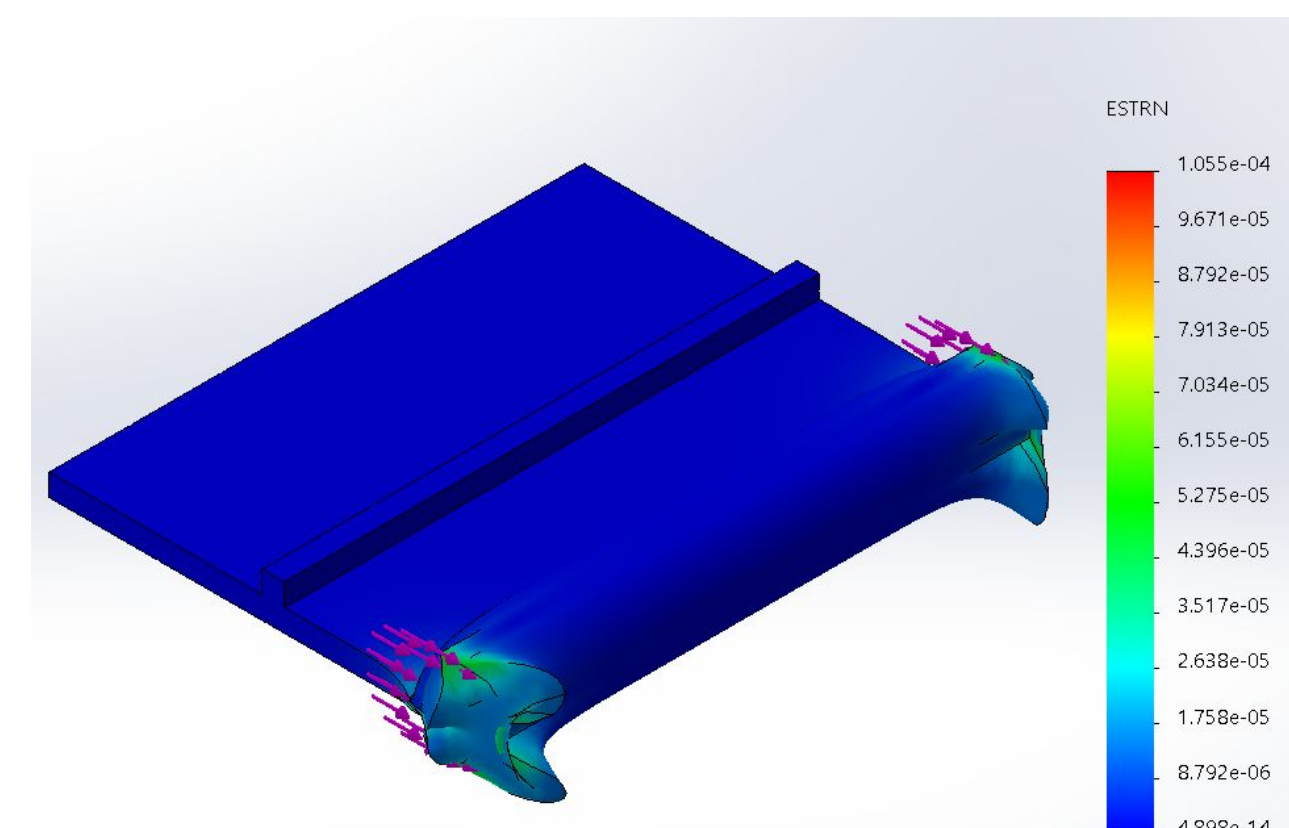

Figure 6: Strain representation of handle design under resistance band load

### Conclusion

- Full design has the ability to withstand the force exerted by the bands.

## Final Design



Figure 7: Original design with updated resistance bands

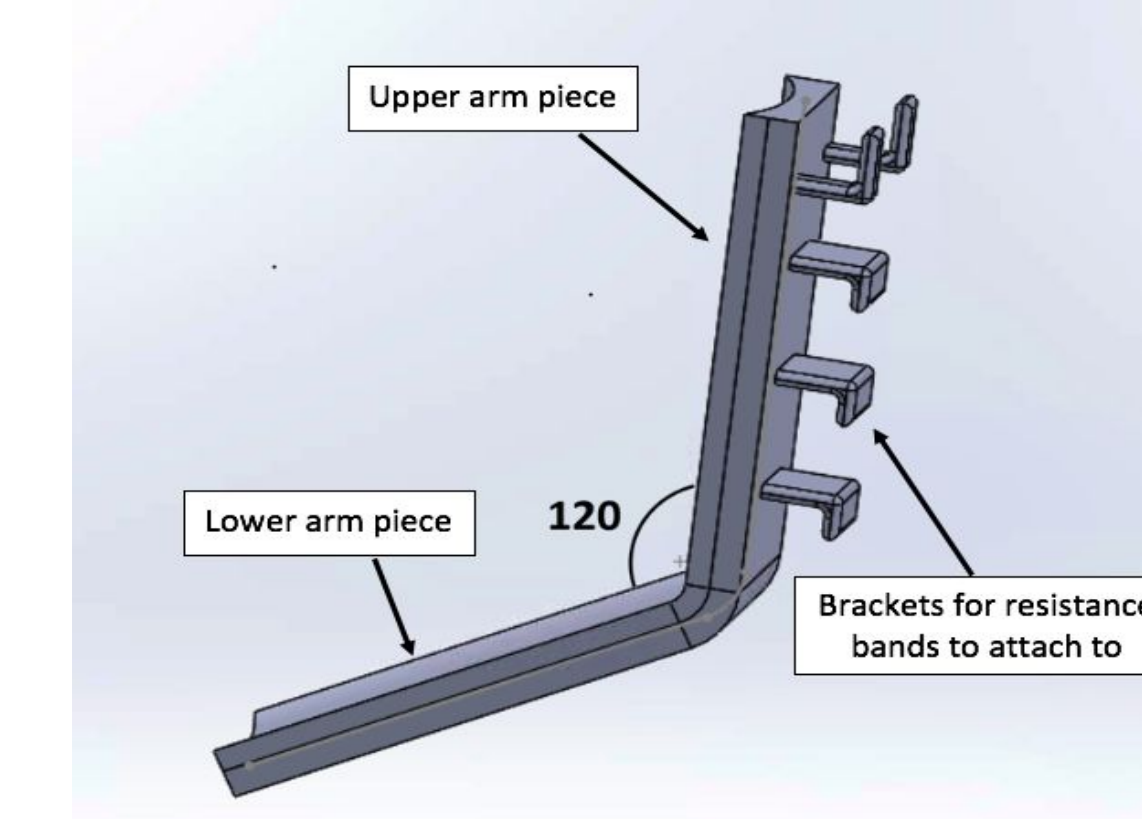

Figure 8: Proposed design of back piece

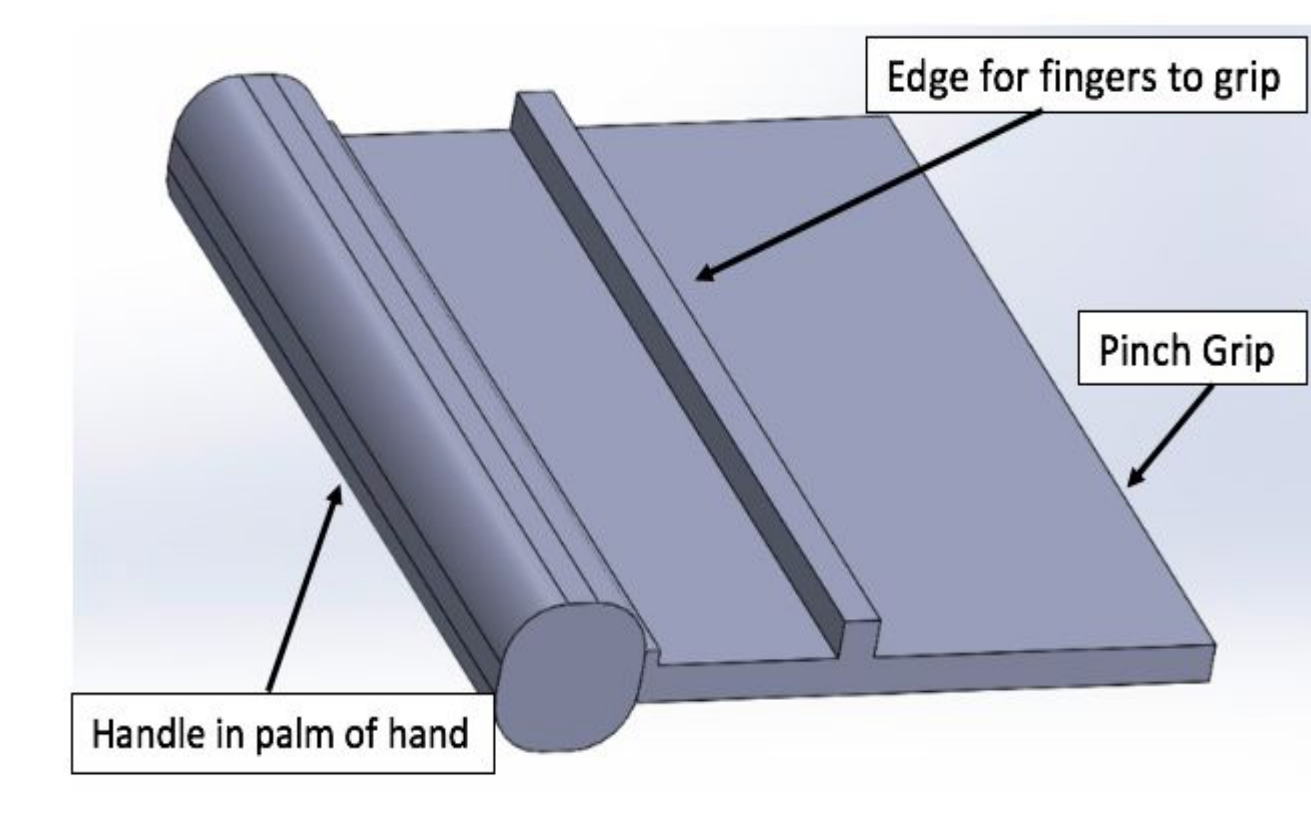

Figure 9: Proposed handle design for grip strengthening

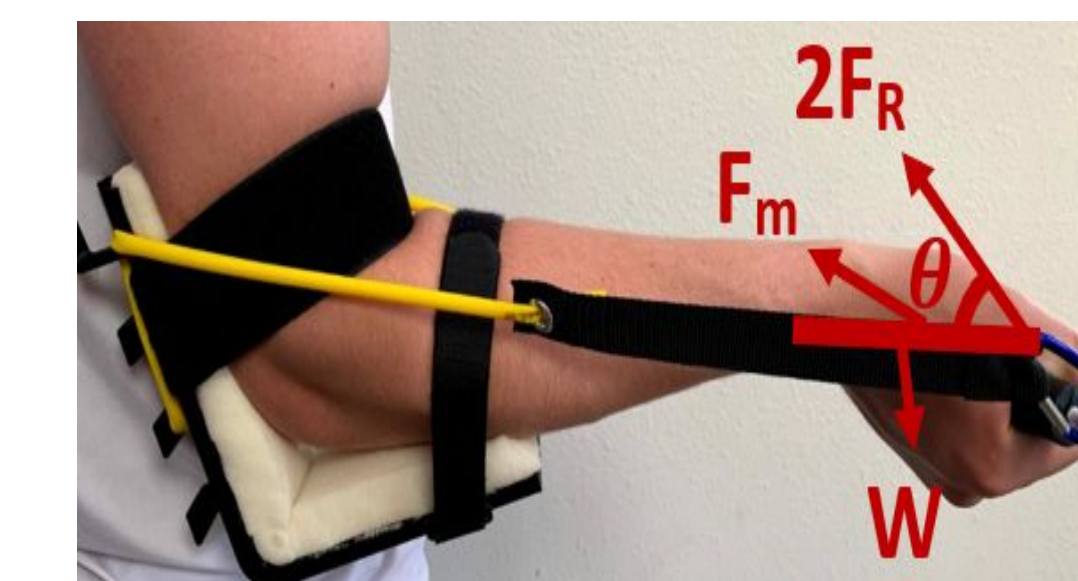

Figure 10: FBD for the extensors and flexors

$$F_m = \frac{L \cdot 2F_R \sin \theta - W \cdot d_w}{MA}$$

$$F_m = \frac{2F_R \sin \theta}{MA}$$

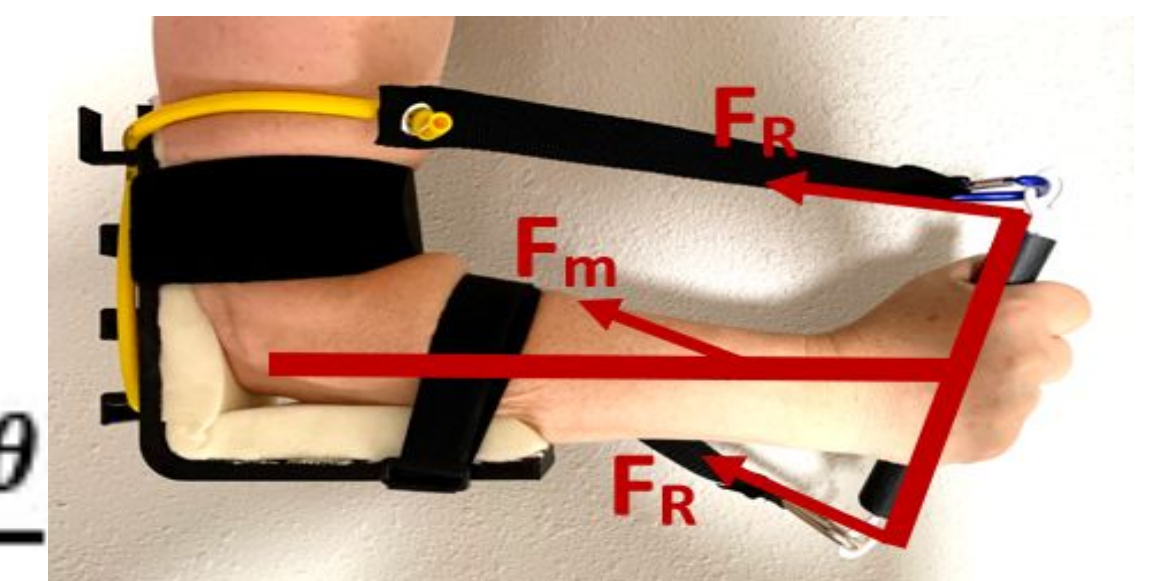

Figure 11: FBD for the pronator teres



Figure 12: Forearm motions used with the device. Shown is the original design with updated resistance bands.

## Future Work

- Tightening mechanism for straps
  - A tension lock similar to those on backpack
- Injection Molding
  - Considered as a mode of fabrication for final prototype after CAD designs are finalized
  - Protolabs Manufacturing
- Removable pinch grip feature
- Testing
  - EMG to confirm isolation of forearm muscles from bicep
  - MTS testing of resistance tubes
  - Usability survey

## Acknowledgements

We would like to thank the following for making this project possible:

- Dr. Chris Vandivort
- Dr. John Puccinelli
- Dr. Christa Wille
- UW-Madison BME Faculty and Staff

## References

- E. Davis, PhD, private communication, Sept. 2019.
- Austin, J. (2019). How to Prevent and Treat Rock Climber's Elbow. [online] Mojo Gear. Available at: <https://mojogear.com/journal/2014/04/01/got-elbows-a-guide-to-coping-with-climbers-elbow/> [Accessed 7 Sep. 2019].
- Edwards, A. and Evans, K. (2019). Stretches to Avoid Elbow Pain from Climbing - Gripped Magazine. [online] Gripped Magazine.
- TeachMe Series, Left Forearm. 2020.
- Vive Health. Hangboard. 2020.
- Handmaster Plus, Handmaster Plus. 2020 a.
- Vive Health, Finger Exerciser. 2020.
- DNQDJ. (2019). Height Percentile Calculator by Gender (United States). [online]. Available at: <https://www.dnqdj.com/height-percentile-calculator-for-men-and-women/> [Accessed 8 Oct. 2019].
- ASTM F2276 - 10(2015). ASTM International - Standards Worldwide. 2015. [Online]. Available: <https://www.astm.org/Standards/F2276.htm> [Accessed: 18-Sep-2019].

# CLIMBER'S FOREARM TRAINER

## Background

- 4 major forearm muscles [1]
- Pronator teres is the muscle of focus
- Movements:
  - Pronation of hand
  - Flexing of the elbow
- Medial Epicondylitis / “Climber’s Elbow”
  - Micro-tearing of the pronator teres [2]
  - overuse of the tendon without sufficient recovery
  - Imbalance in strength of flexor muscles versus the extensor muscles = excessive strain [3]

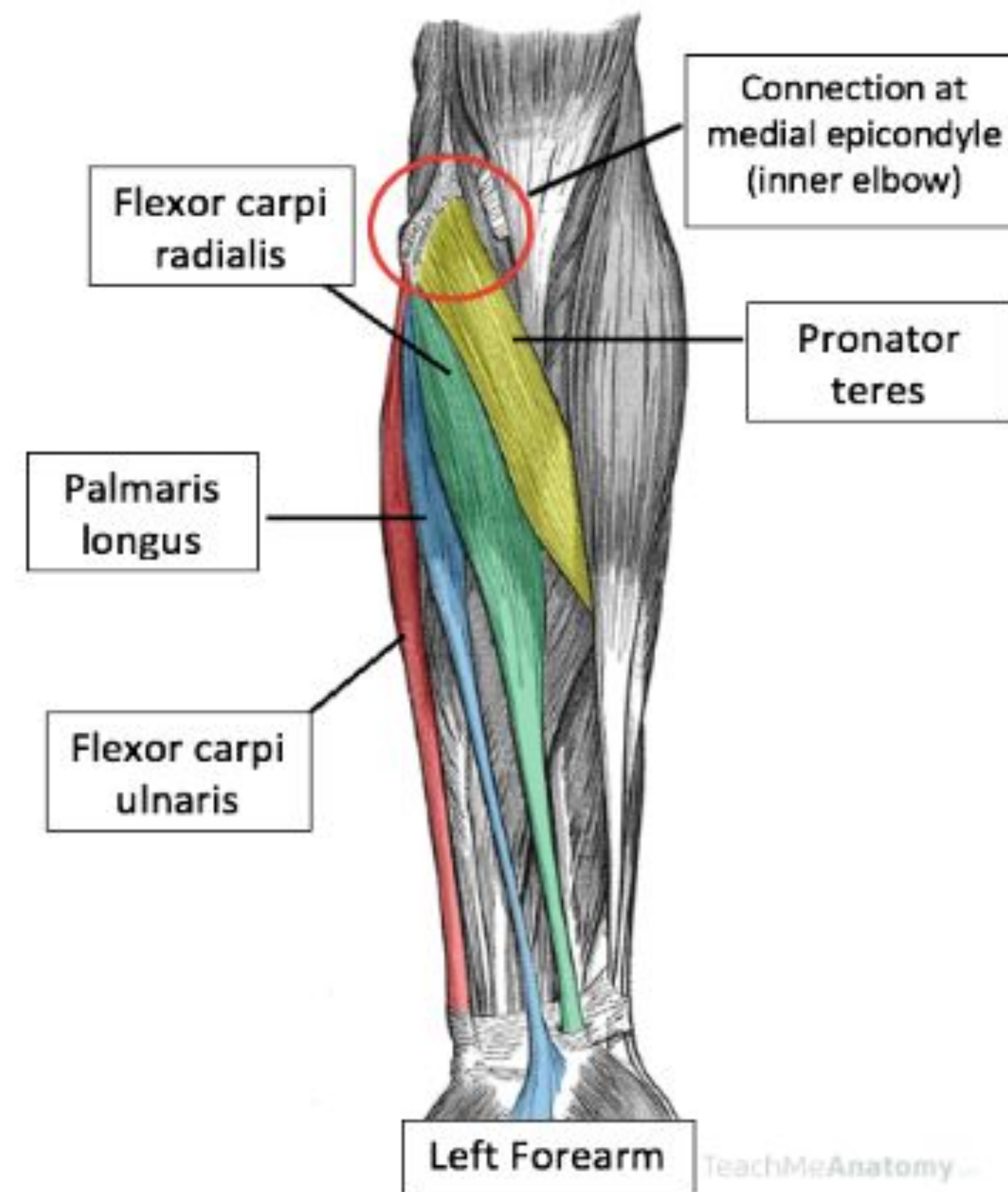

Figure 1: The 4 main muscle groups attached at the medial epicondyle. [4]



## Current Devices



Figure 2: Hangboard [5]



Figure 3: Vive Health Finger Exerciser [7]



Figure 4: Handmaster Plus [6]

# CLIMBER'S FOREARM TRAINER



Team Members: Brittany Glaeser, Kaitlin Lacy, Marissa Harkness, Zoe Schmanski, Jonathon Murphy  
 Client: Dr. Chris Vandivort  
 Advisor: Dr. John Puccinelli



College of Engineering  
 UNIVERSITY OF WISCONSIN-MADISON

College of Engineering  
 UNIVERSITY OF WISCONSIN-MADISON

## Abstract

"Climber's Elbow" is a condition experienced by many climbers where the tendon between the forearm flexors and medial epicondyle of the elbow develops microtears. The Forearm Trainer was designed to aid in prevention and rehabilitation of Climber's Elbow. The device includes variable resistances and a grip strengthener handle. The portable device strengthens the flexors and extensors as well as pronators and supinators of the forearm.

## Motivation

Climber's Elbow, also known as Medial Epicondylitis, affects many rock climbers and can be treated through resistance training of the forearm flexors and extensors. A portable device can help aid in the prevention and rehabilitation of this condition.

## Background

- 4 major forearm muscles [1]
- Pronator teres is the muscle of focus
- Movements:
  - Pronation of hand
  - Flexing of the elbow
- Medial Epicondylitis / "Climber's Elbow"
  - Micro-tearing of the pronator teres [2]
  - overuse of the tendon without sufficient recovery
  - Imbalance in strength of flexor muscles versus the extensor muscles = excessive strain [3]

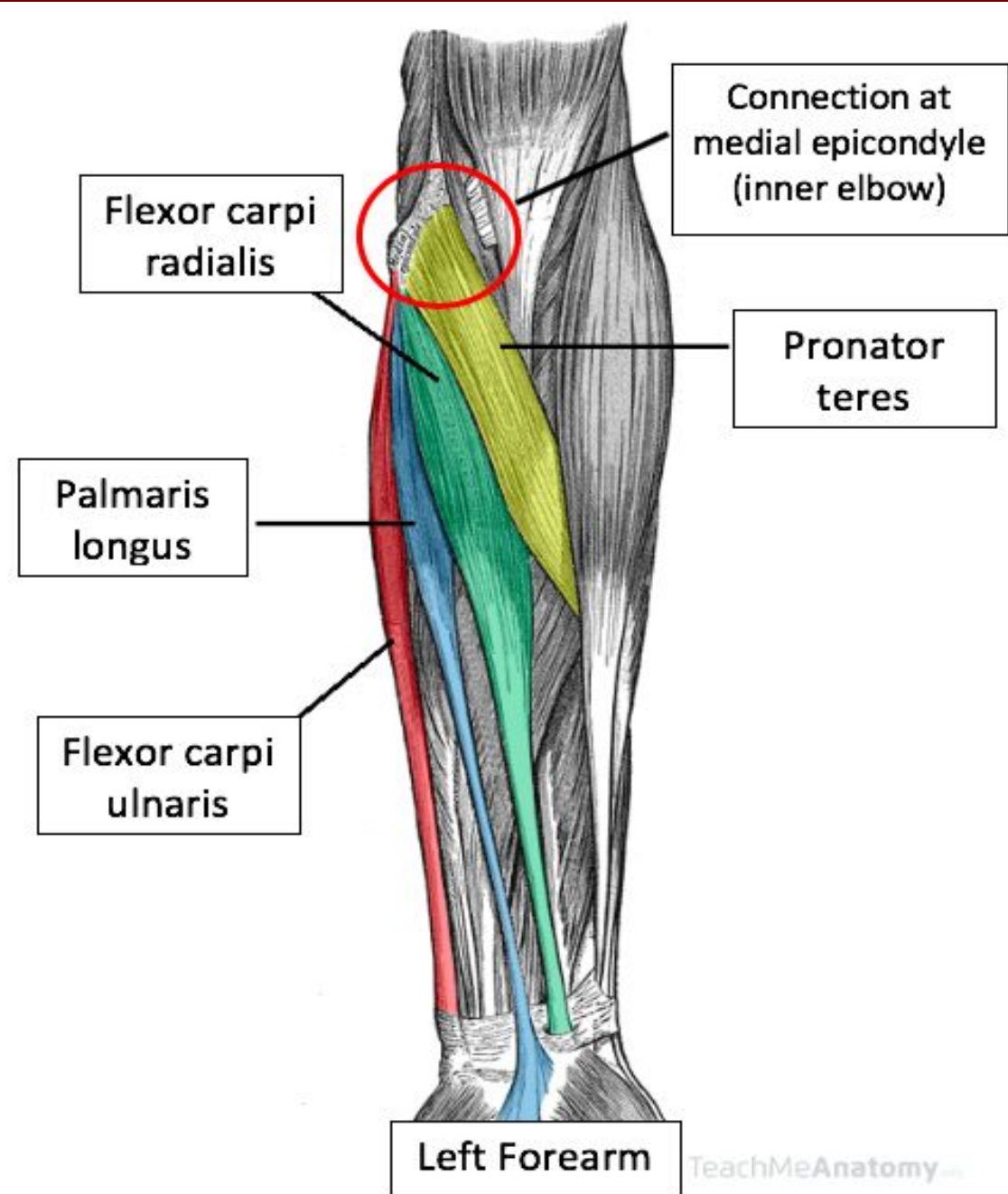

Figure 1: The 4 main muscle groups attached at the medial epicondyle [4]

### Current Devices



Figure 2: Hangboard [5]

Figure 3: Vive Health Finger Exerciser [7]

Figure 4: Handmaster Plus [6]

## Design Criteria

- Effectively targets forearm muscles
- Variable resistances of 5-30 lbs
  - Average forearm length of 23.1 - 26.4 cm
  - Average upper arm length of 29.2 - 33.4 cm [8]
- Durable to withstand daily use for many years
  - Five to ten years for plastic pieces and straps
- Includes grip strengthening component
- Follows ASTM Standards of Fitness [9]
- Easy to use, safe, comfortable, portable and low cost

## Materials

- 3D print - PLA
- Rollerblade straps
- Sponge foam padding
- Flex seal
- Resistance bands
- Carabiners
- 1" Nylon straps
- Hook eye screws
- 0.25" Eyelets
- Brass knurled inserts

Total Costs: \$120.93

## Testing and Results

### FEA of Base Design

- Base design will withstand the stress of the bands
- Maximum deflection of 2.86 mm

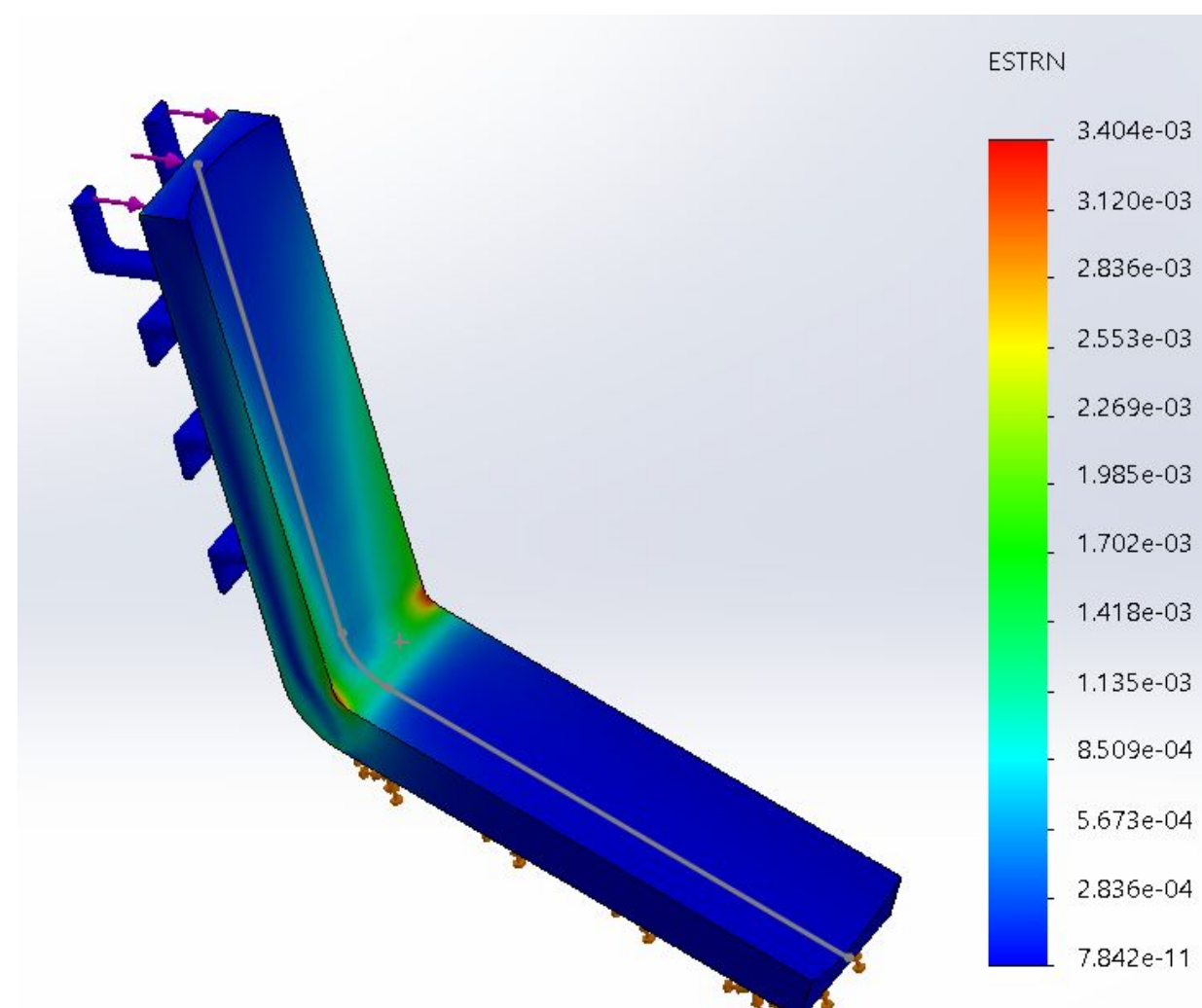

Figure 5: Strain representation of base design under resistance band load

### FEA of Handle Design

- Handle design will withstand the stress of the bands
- Maximum deflection of  $3.57 \times 10^{-4}$  mm.

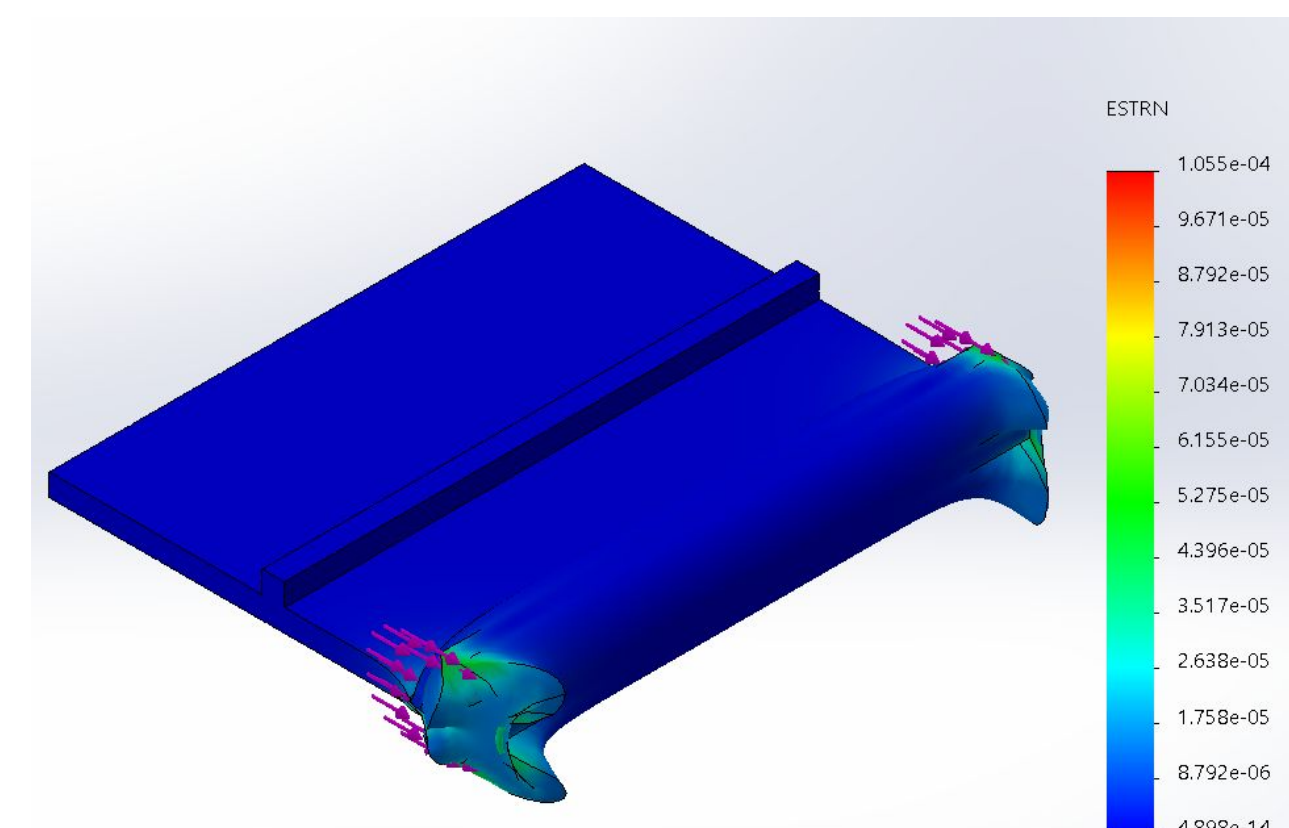

Figure 6: Strain representation of handle design under resistance band load

### Conclusion

- Full design has the ability to withstand the force exerted by the bands.

## Final Design



Figure 7: Original design with updated resistance bands

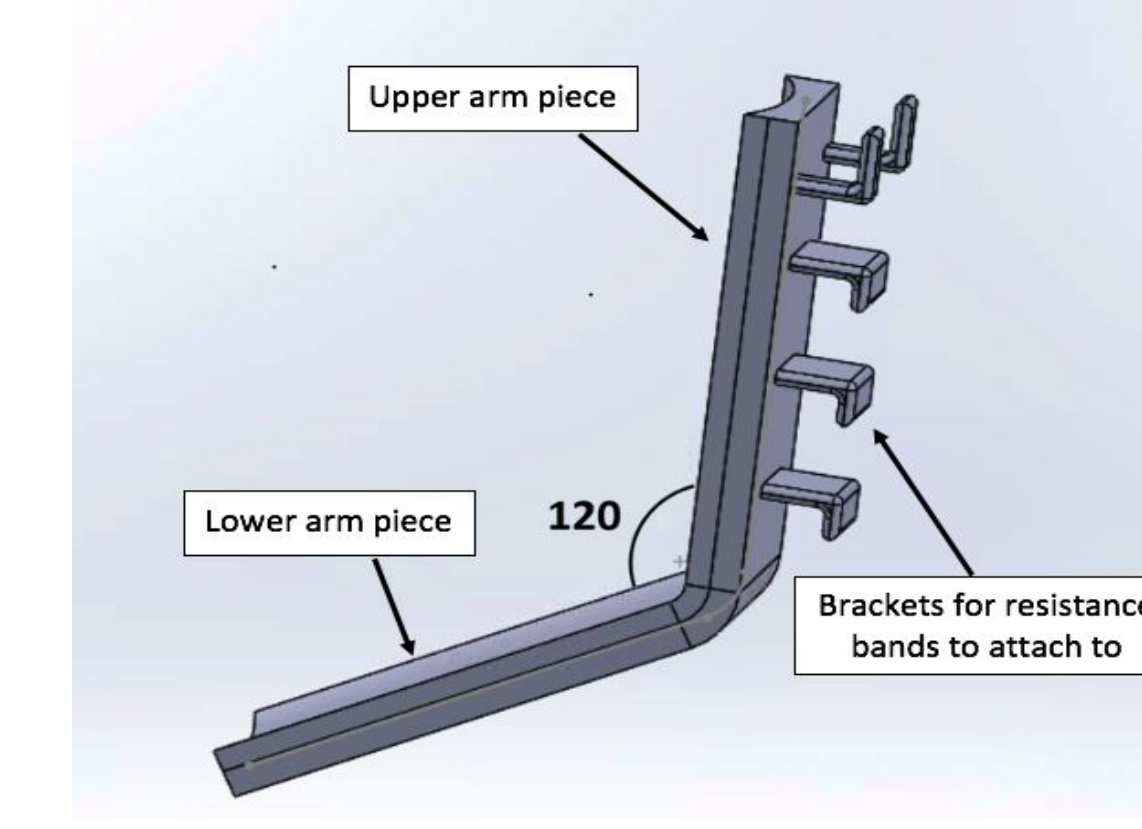

Figure 8: Proposed design of back piece

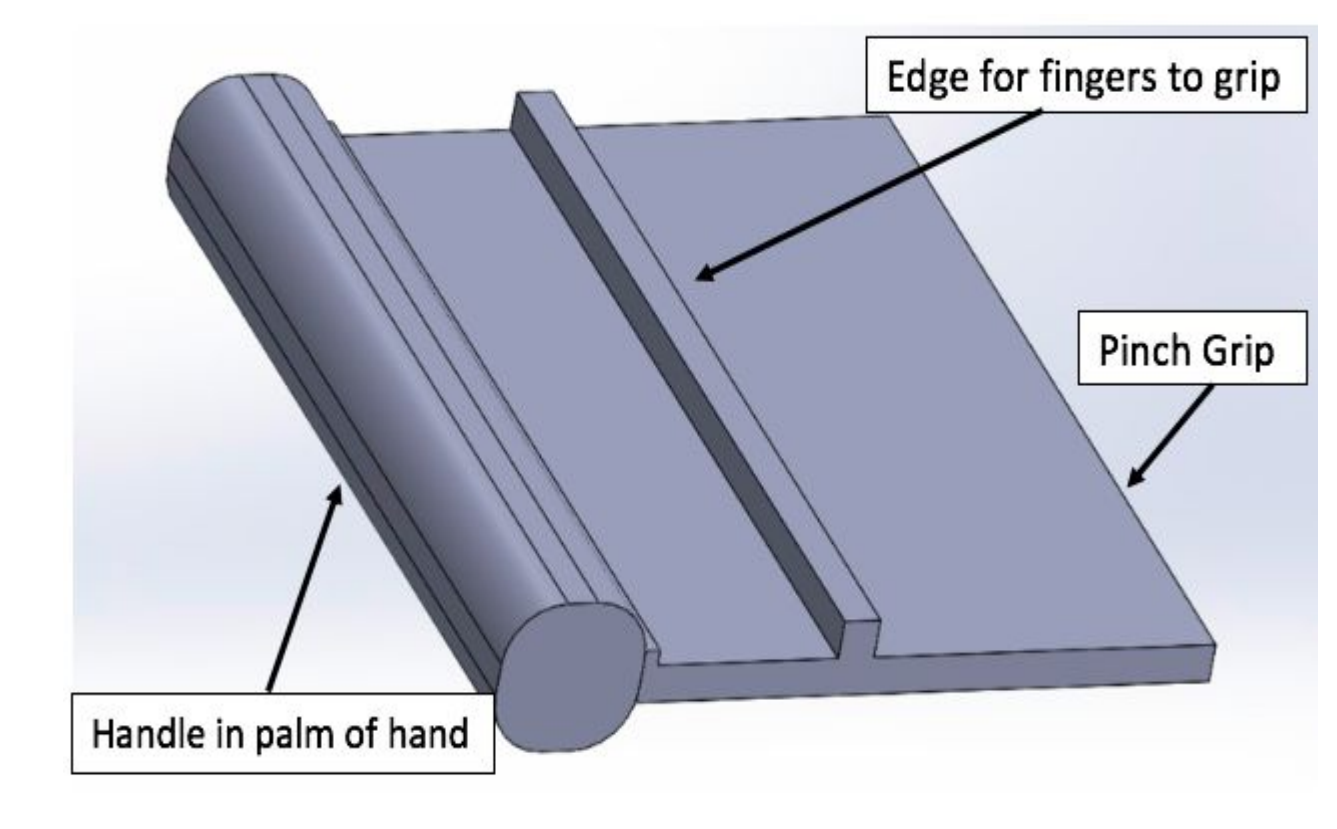

Figure 9: Proposed handle design for grip strengthening

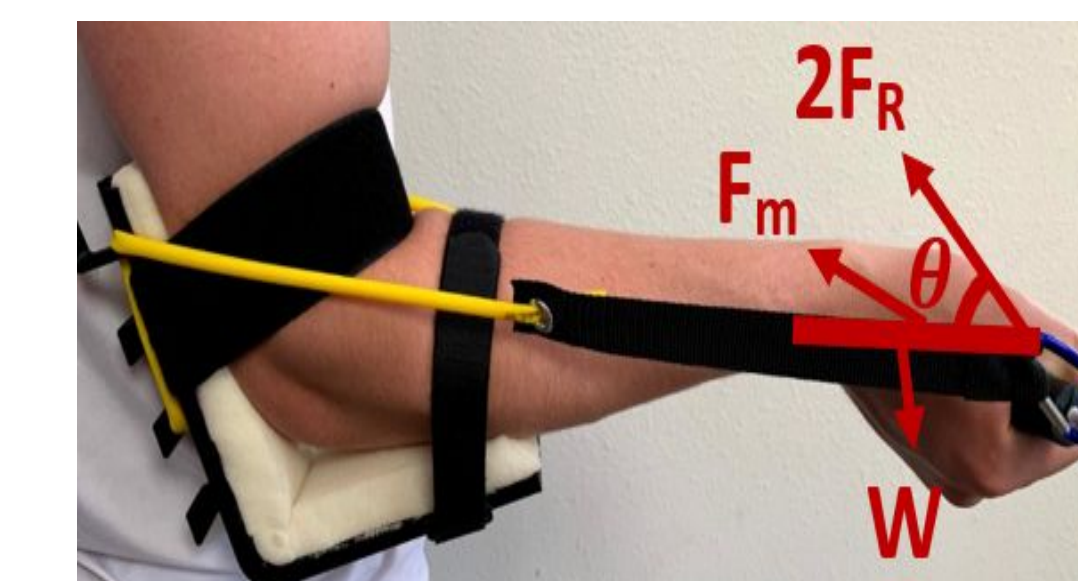

Figure 10: FBD for the extensors and flexors

$$F_m = \frac{L \cdot 2F_R \sin \theta - W \cdot d_w}{MA}$$

$$F_m = \frac{2F_R \sin \theta}{MA}$$

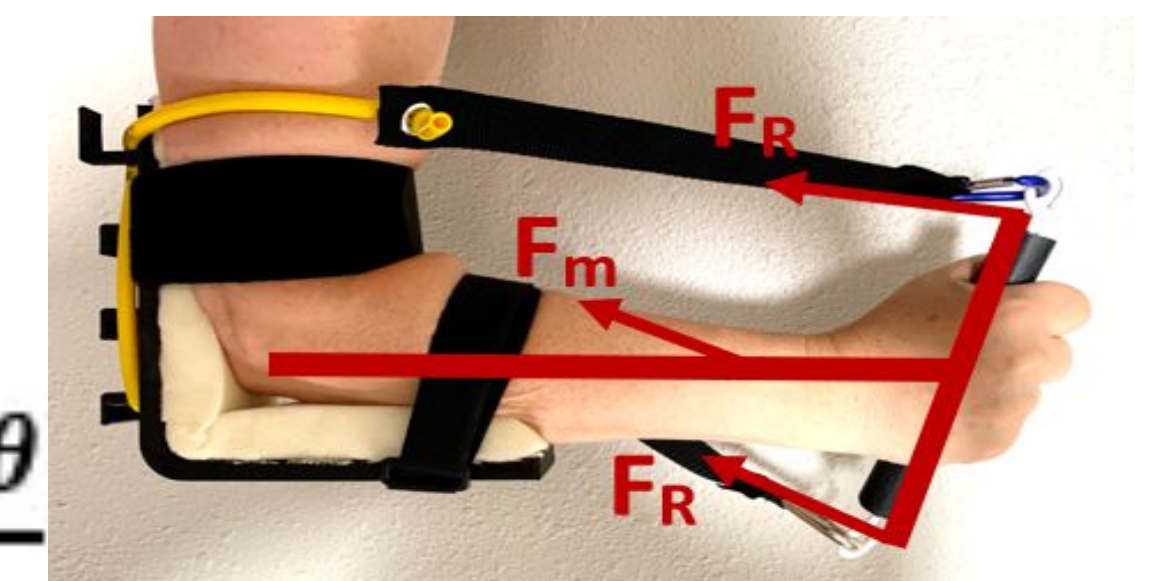

Figure 11: FBD for the pronator teres



Figure 12: Forearm motions used with the device. Shown is the original design with updated resistance bands.

## Future Work

- Tightening mechanism for straps
  - A tension lock similar to those on backpack
- Injection Molding
  - Considered as a mode of fabrication for final prototype after CAD designs are finalized
  - Protolabs Manufacturing
- Removable pinch grip feature
- Testing
  - EMG to confirm isolation of forearm muscles from bicep
  - MTS testing of resistance tubes
  - Usability survey

## Acknowledgements

We would like to thank the following for making this project possible:

- Dr. Chris Vandivort
- Dr. John Puccinelli
- Dr. Christa Wille
- UW-Madison BME Faculty and Staff

## References

- E. Davis, PhD, private communication, Sept. 2019.
- Avolio, J. (2019). How to Prevent and Treat Rock Climber's Elbow. [online] Mojo Gear. Available at: <https://mojogear.com/journal/2014/04/01/got-elbows-a-guide-to-coping-with-climbers-elbow/> [Accessed 7 Sep. 2019].
- Edwards, A. and Evans, K. (2019). Stretches to Avoid Elbow Pain from Climbing - Gripped Magazine. [online] Gripped Magazine.
- TeachMe Series, Left Forearm. 2020.
- Vive Health. 2020.
- Handmaster Plus, Handmaster Plus. 2020 a.
- Vive Health, Finger Exerciser. 2020.
- DNQDJ. (2019). Height Percentile Calculator by Gender (United States). [online]. Available at: <https://www.dnqdj.com/height-percentile-calculator-for-men-and-women/> [Accessed 8 Oct. 2019].
- ASTM F2276 - 10(2015). ASTM International - Standards Worldwide. 2015. [Online]. Available: <https://www.astm.org/Standards/F2276.htm> [Accessed: 18-Sep-2019].

# CLIMBER'S FOREARM TRAINER

## Design Criteria

- Effectively targets forearm muscles
- Variable resistances of 5-30 lbs
- Adaptable to different sized forearms and hands
  - Average forearm length of 23.1 - 26.4 cm
  - Average upper arm length of 29.2 - 33.4 cm [8]
- Durable to withstand daily use for many years
  - Five to ten years for plastic pieces and straps
- Includes grip strengthening component
- Follows ASTM Standards of Fitness [9]
- Easy to use, safe, comfortable, portable and low cost



# CLIMBER'S FOREARM TRAINER



Team Members: Brittany Glaeser, Kaitlin Lacy, Marissa Harkness, Zoe Schmanski, Jonathon Murphy  
 Client: Dr. Chris Vandivort  
 Advisor: Dr. John Puccinelli



College of Engineering  
 UNIVERSITY OF WISCONSIN-MADISON

College of Engineering  
 UNIVERSITY OF WISCONSIN-MADISON

## Abstract

"Climber's Elbow" is a condition experienced by many climbers where the tendon between the forearm flexors and medial epicondyle of the elbow develops microtears. The Forearm Trainer was designed to aid in prevention and rehabilitation of Climber's Elbow. The device includes variable resistances and a grip strengthener handle. The portable device strengthens the flexors and extensors as well as pronators and supinators of the forearm.

## Motivation

Climber's Elbow, also known as Medial Epicondylitis, affects many rock climbers and can be treated through resistance training of the forearm flexors and extensors. A portable device can help aid in the prevention and rehabilitation of this condition.

## Background

- 4 major forearm muscles [1]
- Pronator teres is the muscle of focus
- Movements:
  - Pronation of hand
  - Flexing of the elbow
- Medial Epicondylitis / "Climber's Elbow"
  - Micro-tearing of the pronator teres [2]
  - overuse of the tendon without sufficient recovery
  - Imbalance in strength of flexor muscles versus the extensor muscles = excessive strain [3]

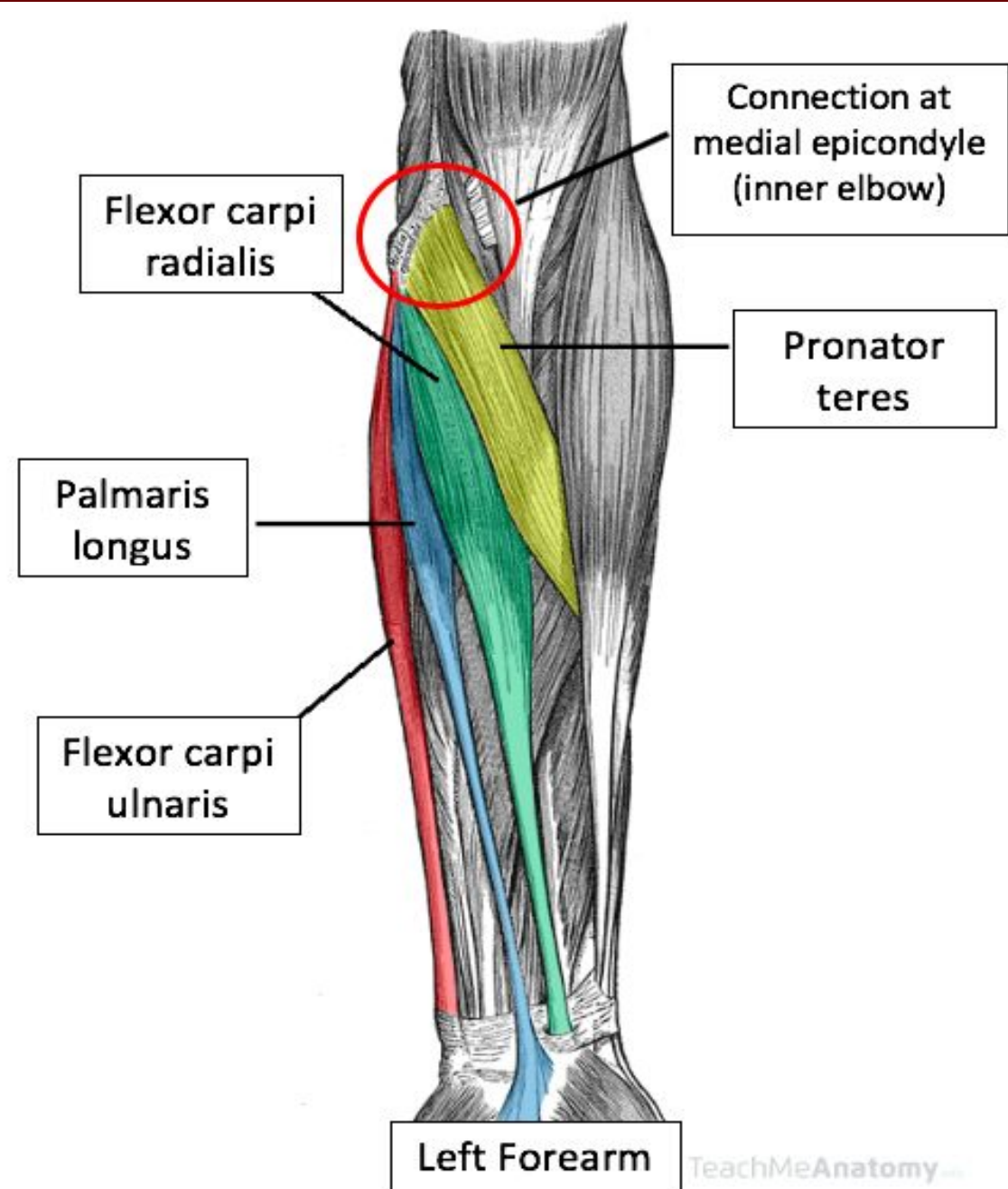

Figure 1: The 4 main muscle groups attached at the medial epicondyle [4]

### Current Devices



Figure 2: Hangboard [5]

Figure 3: Vive Health Finger Exerciser [7]

Figure 4: Handmaster Plus [6]

## Design Criteria

- Effectively targets forearm muscles
- Variable resistances of 5-30 lbs
  - Average forearm length of 23.1 - 26.4 cm
  - Average upper arm length of 29.2 - 33.4 cm [8]
- Durable to withstand daily use for many years
  - Five to ten years for plastic pieces and straps
- Includes grip strengthening component
- Follows ASTM Standards of Fitness [9]
- Easy to use, safe, comfortable, portable and low cost

## Materials

- 3D print - PLA
- Rollerblade straps
- Sponge foam padding
- Flex seal
- Resistance bands
- Carabiners
- 1" Nylon straps
- Hook eye screws
- 0.25" Eyelets
- Brass knurled inserts

Total Costs: \$120.93

## Testing and Results

### FEA of Base Design

- Base design will withstand the stress of the bands
- Maximum deflection of 2.86 mm

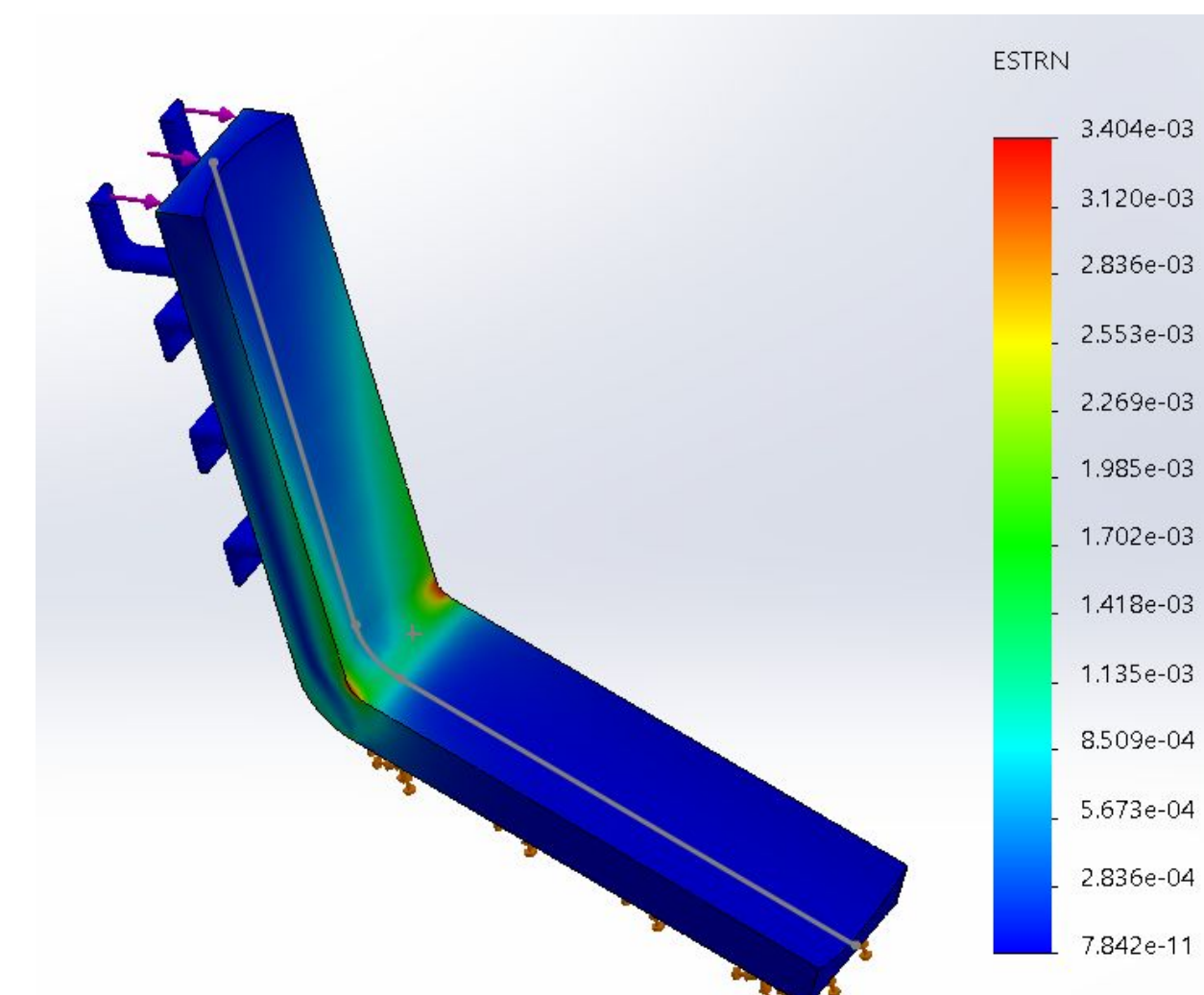

Figure 5: Strain representation of base design under resistance band load

### FEA of Handle Design

- Handle design will withstand the stress of the bands
- Maximum deflection of  $3.57 \times 10^{-4}$  mm.

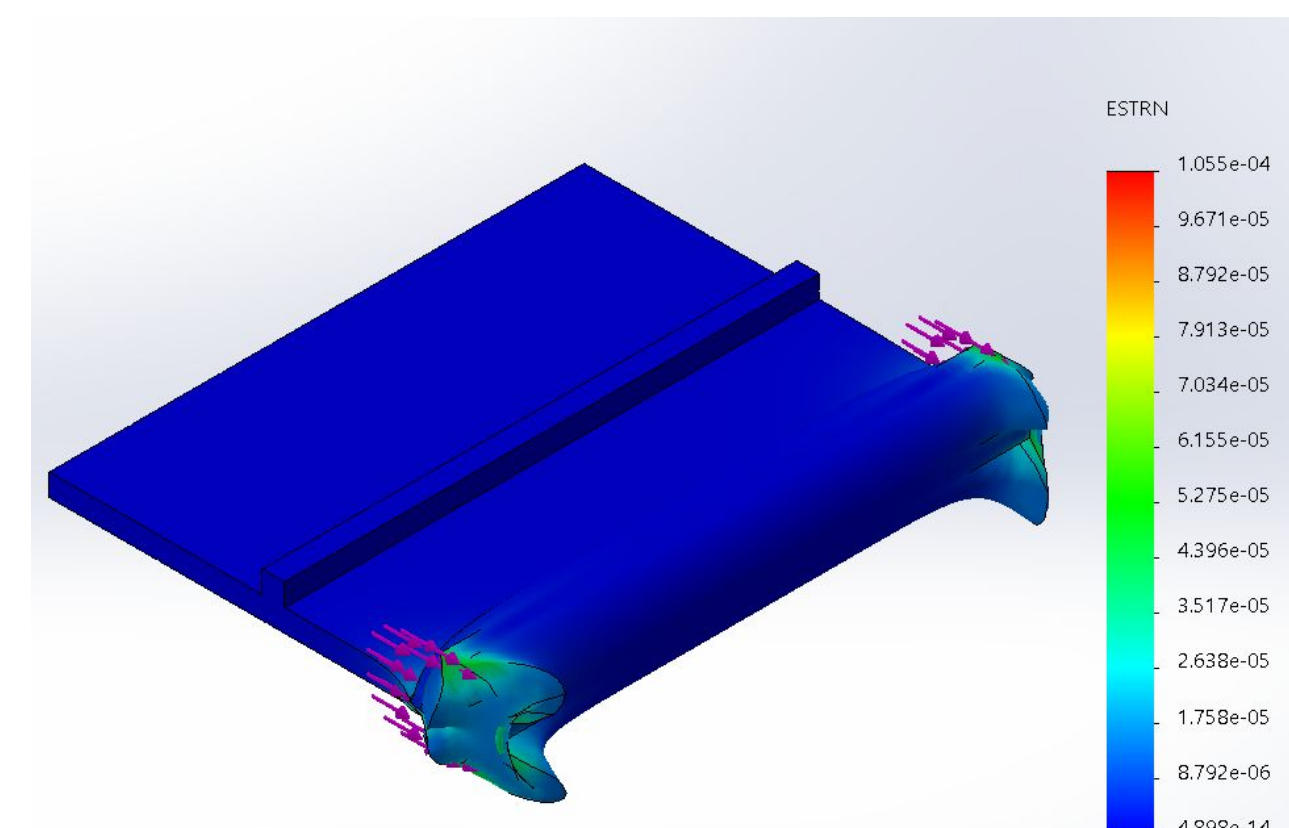

Figure 6: Strain representation of handle design under resistance band load

### Conclusion

- Full design has the ability to withstand the force exerted by the bands.

## Final Design



Figure 7: Original design with updated resistance bands

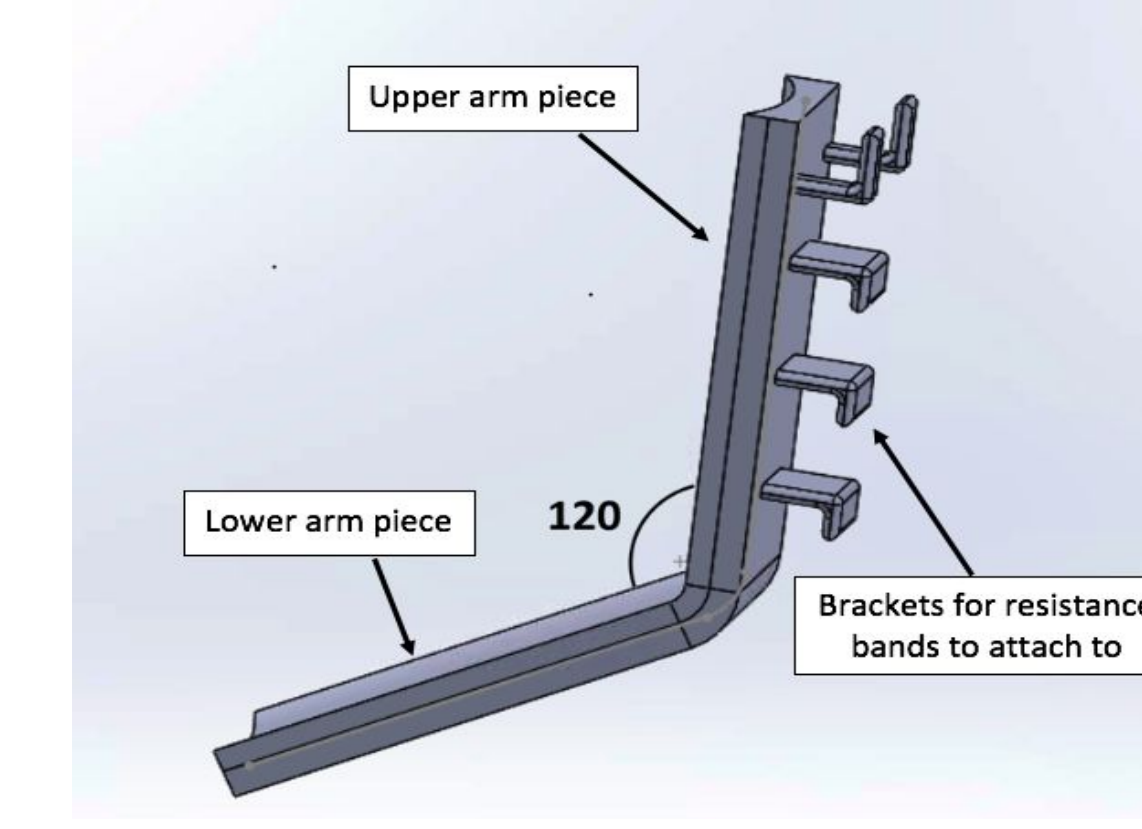

Figure 8: Proposed design of back piece

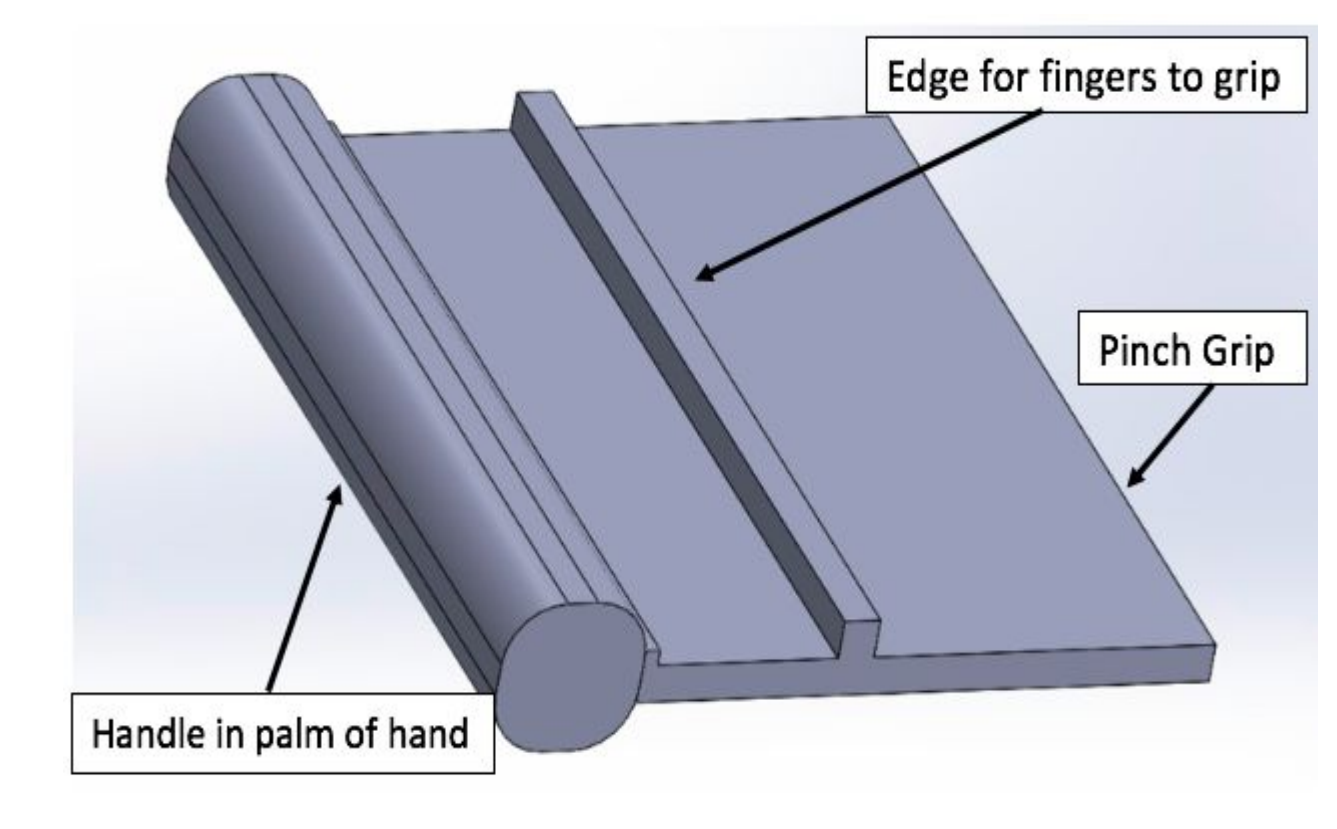

Figure 9: Proposed handle design for grip strengthening

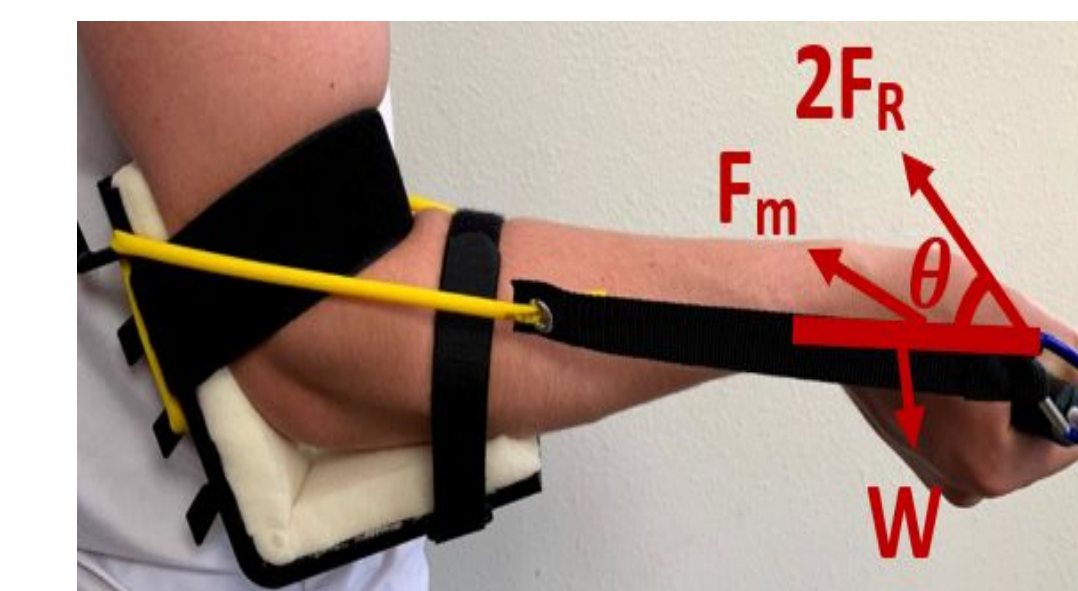

Figure 10: FBD for the extensors and flexors

$$F_m = \frac{L \cdot 2F_R \sin \theta - W \cdot d_w}{MA}$$

$$F_m = \frac{2F_R \sin \theta}{MA}$$

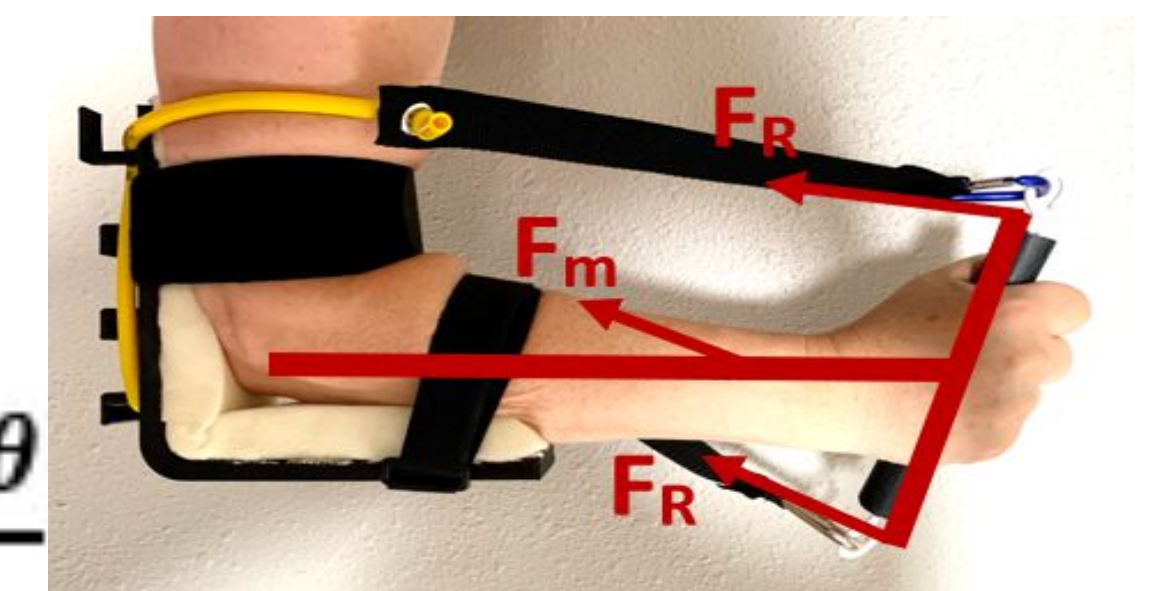

Figure 11: FBD for the pronator teres



Figure 12: Forearm motions used with the device. Shown is the original design with updated resistance bands.

## Future Work

- Tightening mechanism for straps
  - A tension lock similar to those on backpack
- Injection Molding
  - Considered as a mode of fabrication for final prototype after CAD designs are finalized
  - Protolabs Manufacturing
- Removable pinch grip feature
- Testing
  - EMG to confirm isolation of forearm muscles from bicep
  - MTS testing of resistance tubes
  - Usability survey

## Acknowledgements

We would like to thank the following for making this project possible:

- Dr. Chris Vandivort
- Dr. John Puccinelli
- Dr. Christa Wille
- UW-Madison BME Faculty and Staff

## References

- E. Davis, PhD, private communication, Sept. 2019.
- Andros, I. (2019). How to Prevent and Treat Rock Climber's Elbow. [online] Mojo Gear. Available at: <https://mojogear.com/journal/2014/04/01/got-elbows-a-guide-to-coping-with-climbers-elbow/> [Accessed 7 Sep. 2019].
- Edwards, A. and Evans, K. (2019). Stretches to Avoid Elbow Pain from Climbing - Gripped Magazine. [online] Gripped Magazine.
- TeachMe Series, Left Forearm. 2020.
- Vive Health. 2020.
- Handmaster Plus, Handmaster Plus. 2020 a.
- Vive Health, Finger Exerciser. 2020.
- DNQDJ. (2019). Height Percentile Calculator by Gender (United States). [online]. Available at: <https://www.dnqdj.com/height-percentile-calculator-for-men-and-women/> [Accessed 8 Oct. 2019].
- ASTM F2276 - 10(2015). ASTM International - Standards Worldwide. 2015. [Online]. Available: <https://www.astm.org/Standards/F2276.htm> [Accessed: 18-Sep-2019].



# CLIMBER'S FOREARM TRAINER

## Materials

- 3D print - PLA
- Rollerblade straps
- Sponge foam padding
- Flex seal
- Resistance bands
- Carabiners
- 1" Nylon straps
- Hook eye screws
- 0.25" Eyelets
- Brass knurled inserts

**Total Costs: \$120.93**



# CLIMBER'S FOREARM TRAINER



Team Members: Brittany Glaeser, Kaitlin Lacy, Marissa Harkness, Zoe Schmanski, Jonathon Murphy  
 Client: Dr. Chris Vandivort  
 Advisor: Dr. John Puccinelli



College of Engineering  
 UNIVERSITY OF WISCONSIN-MADISON

College of Engineering  
 UNIVERSITY OF WISCONSIN-MADISON

## Abstract

"Climber's Elbow" is a condition experienced by many climbers where the tendon between the forearm flexors and medial epicondyle of the elbow develops microtears. The Forearm Trainer was designed to aid in prevention and rehabilitation of Climber's Elbow. The device includes variable resistances and a grip strengthener handle. The portable device strengthens the flexors and extensors as well as pronators and supinators of the forearm.

## Motivation

Climber's Elbow, also known as Medial Epicondylitis, affects many rock climbers and can be treated through resistance training of the forearm flexors and extensors. A portable device can help aid in the prevention and rehabilitation of this condition.

## Background

- 4 major forearm muscles [1]
- Pronator teres is the muscle of focus
- Movements:
  - Pronation of hand
  - Flexing of the elbow
- Medial Epicondylitis / "Climber's Elbow"
  - Micro-tearing of the pronator teres [2]
  - overuse of the tendon without sufficient recovery
  - Imbalance in strength of flexor muscles versus the extensor muscles = excessive strain [3]

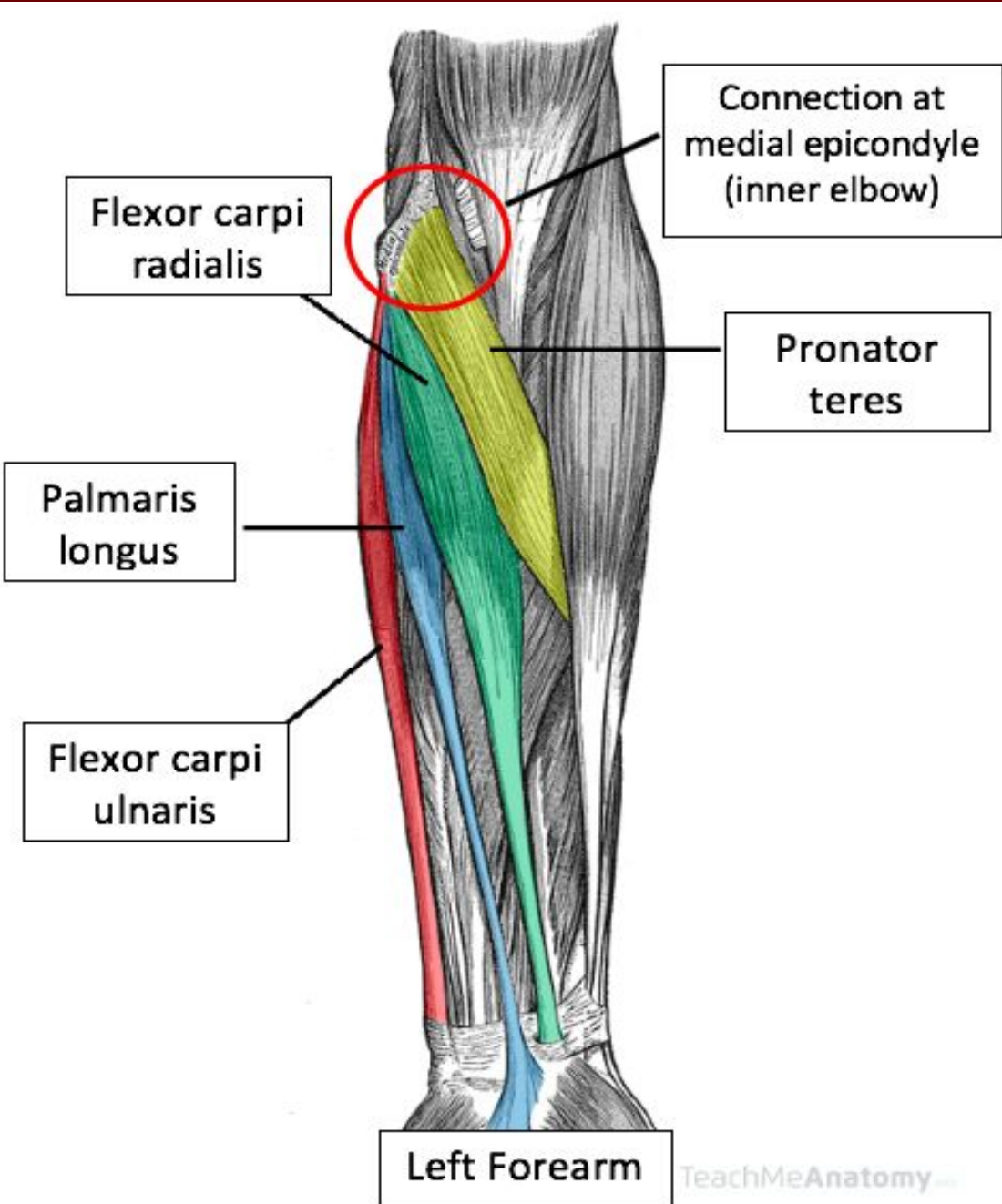

Figure 1: The 4 main muscle groups attached at the medial epicondyle [4]

### Current Devices



Figure 2: Hangboard [5]

Figure 3: Vive Health Finger Exerciser [7]

Figure 4: Handmaster Plus [6]

## Design Criteria

- Effectively targets forearm muscles
- Variable resistances of 5-30 lbs
  - Average forearm length of 23.1 - 26.4 cm
  - Average upper arm length of 29.2 - 33.4 cm [8]
- Durable to withstand daily use for many years
  - Five to ten years for plastic pieces and straps
- Includes grip strengthening component
- Follows ASTM Standards of Fitness [9]
- Easy to use, safe, comfortable, portable and low cost

## Materials

- 3D print - PLA
- Rollerblade straps
- Sponge foam padding
- Flex seal
- Resistance bands
- Carabiners
- 1" Nylon straps
- Hook eye screws
- 0.25" Eyelets
- Brass knurled inserts

Total Costs: \$120.93

## Testing and Results

### FEA of Base Design

- Base design will withstand the stress of the bands
- Maximum deflection of 2.86 mm

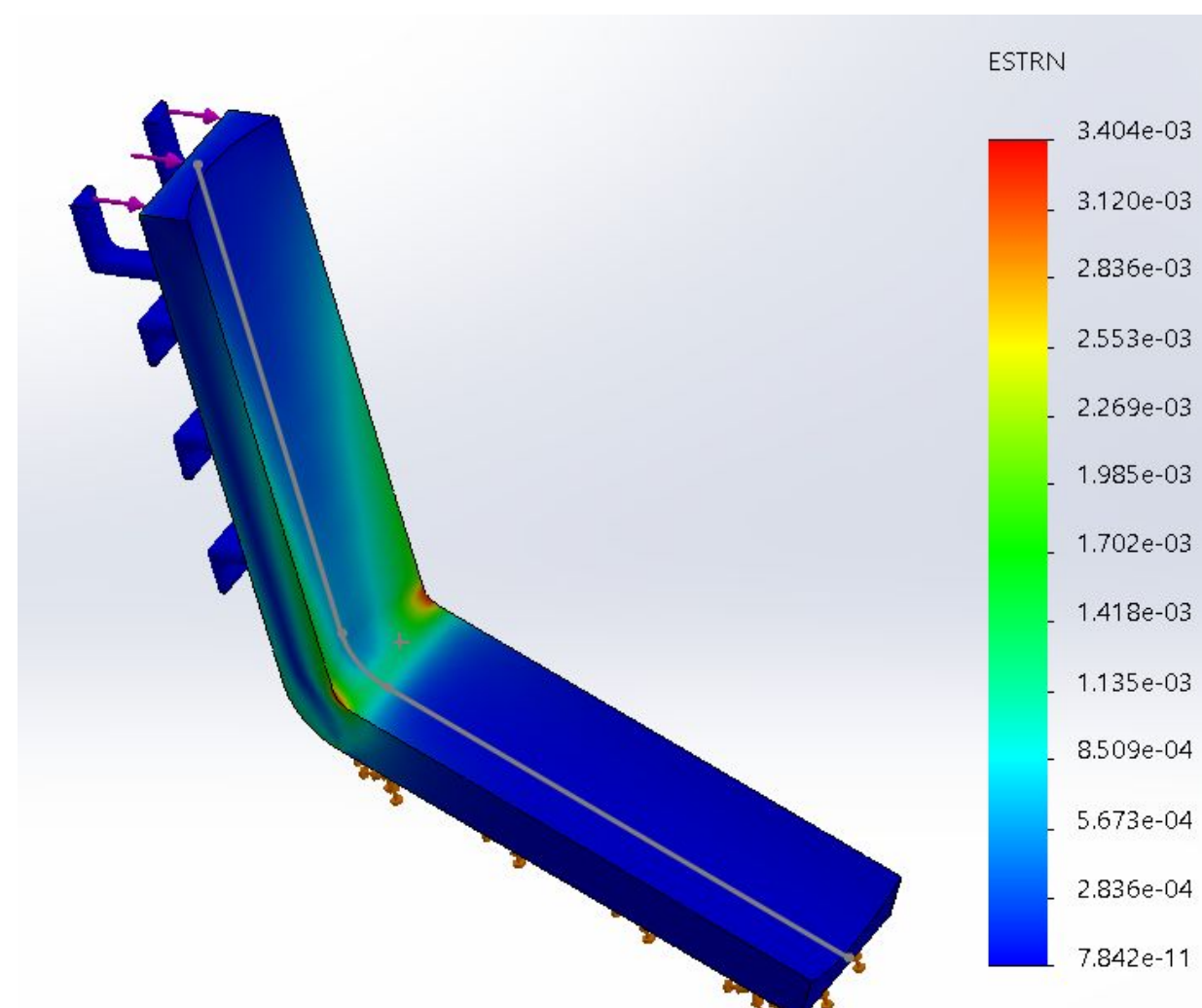

Figure 5: Strain representation of base design under resistance band load

### FEA of Handle Design

- Handle design will withstand the stress of the bands
- Maximum deflection of  $3.57 \times 10^{-4}$  mm.

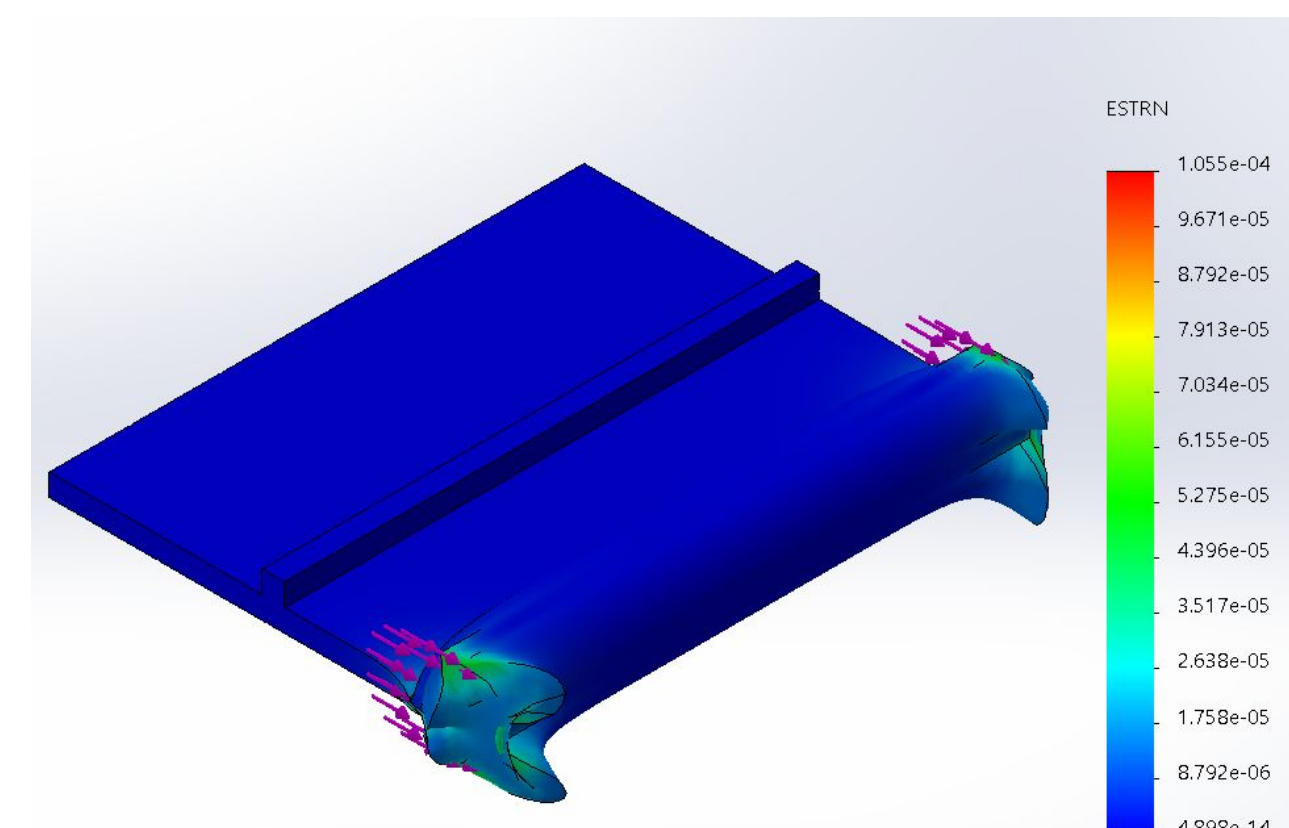

Figure 6: Strain representation of handle design under resistance band load

### Conclusion

- Full design has the ability to withstand the force exerted by the bands.

## Final Design



Figure 7: Original design with updated resistance bands

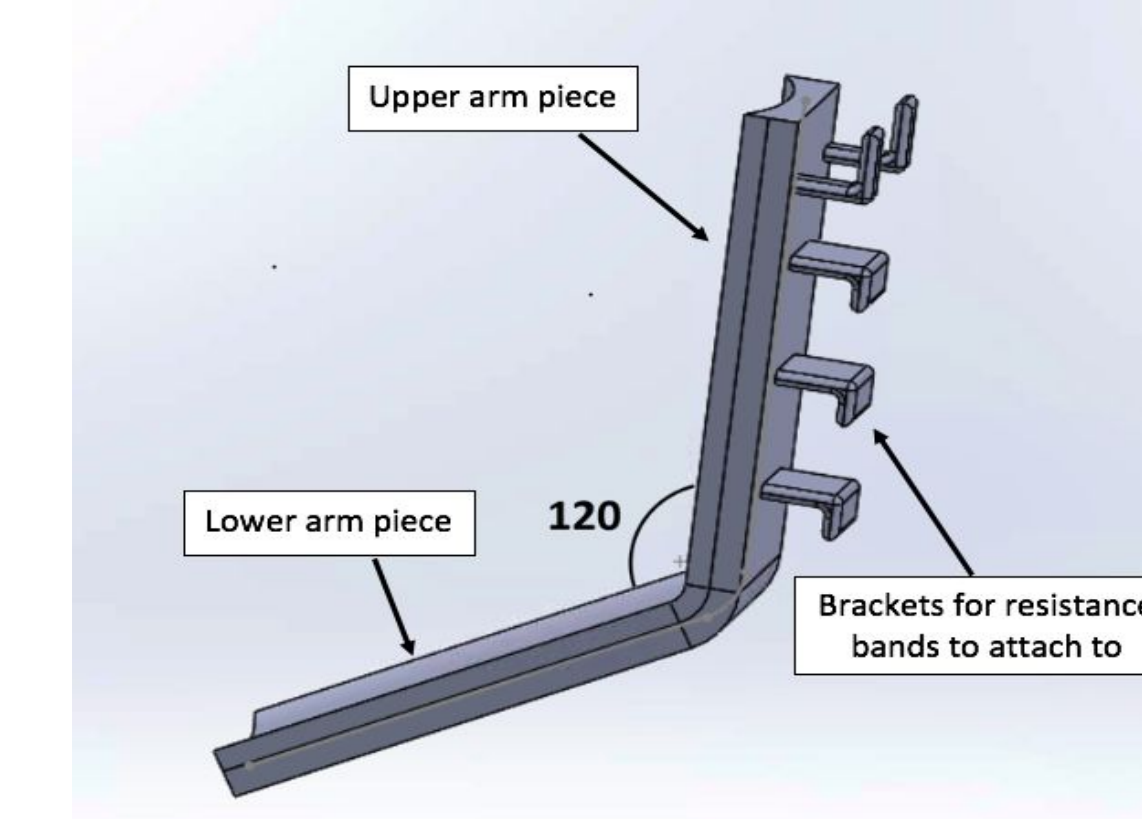

Figure 8: Proposed design of back piece

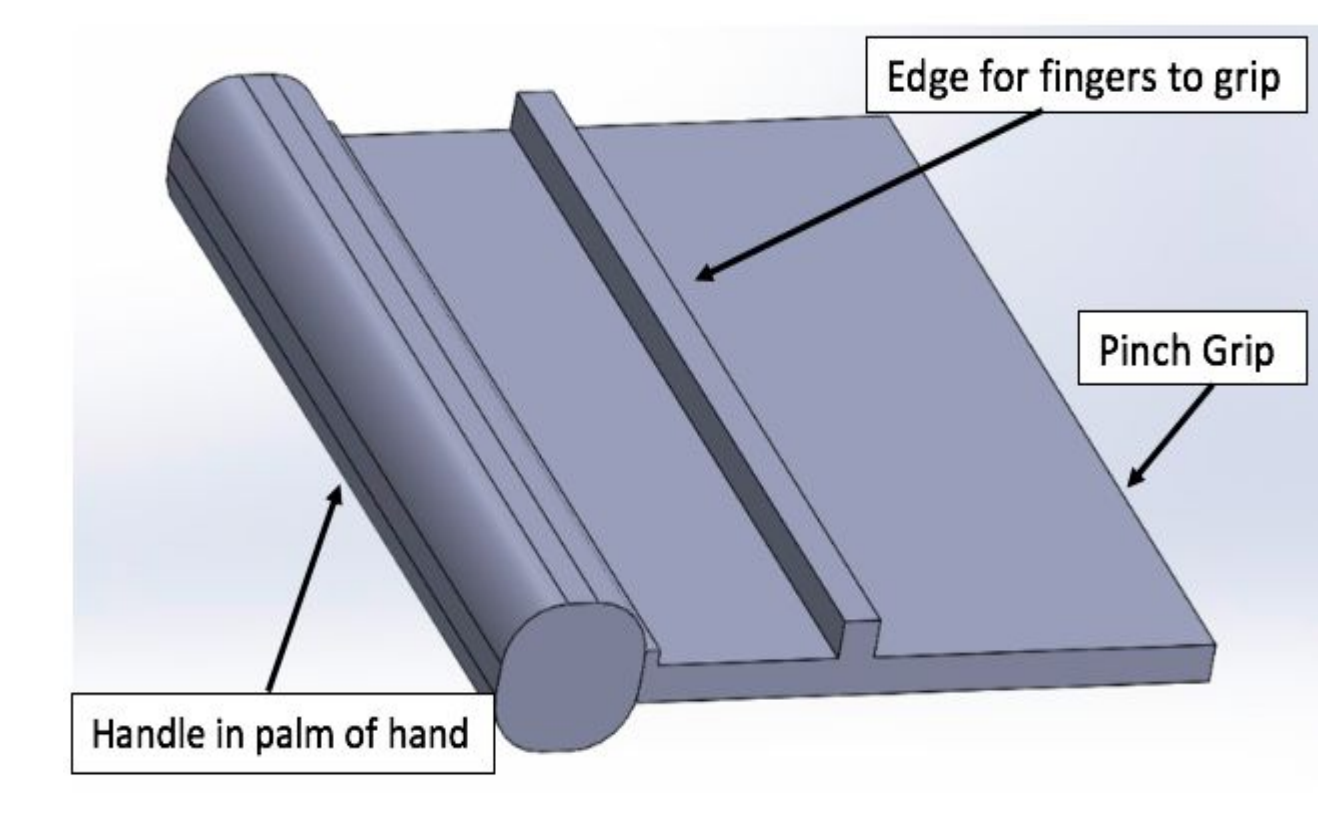

Figure 9: Proposed handle design for grip strengthening

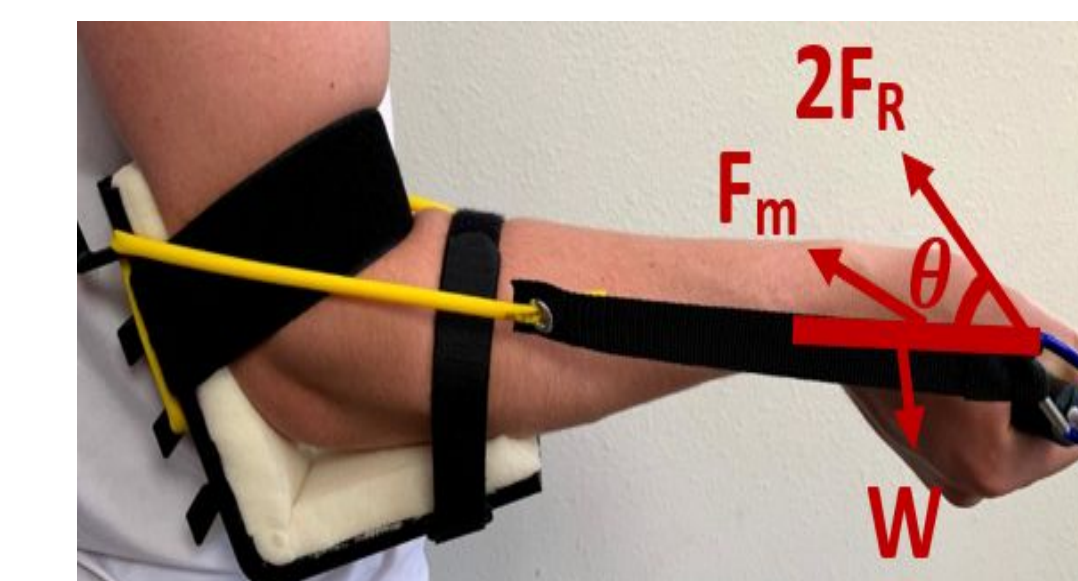

Figure 10: FBD for the extensors and flexors

$$F_m = \frac{L \cdot 2F_R \sin \theta - W \cdot d_w}{MA}$$

$$F_m = \frac{2F_R \sin \theta}{MA}$$

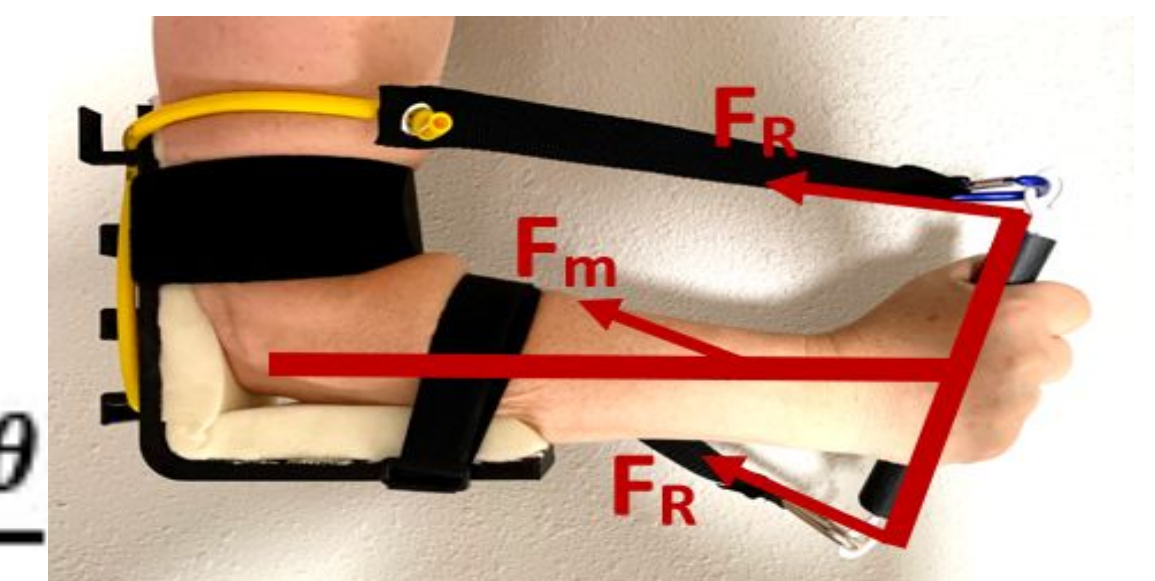

Figure 11: FBD for the pronator teres

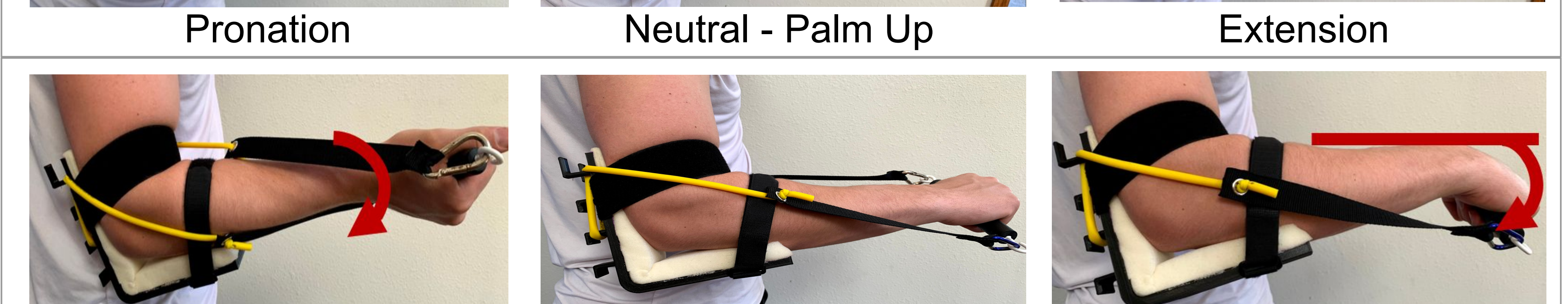

Figure 12: Forearm motions used with the device. Shown is the original design with updated resistance bands.

## Future Work

- Tightening mechanism for straps
  - A tension lock similar to those on backpack
- Injection Molding
  - Considered as a mode of fabrication for final prototype after CAD designs are finalized
  - Protolabs Manufacturing
- Removable pinch grip feature
- Testing
  - EMG to confirm isolation of forearm muscles from bicep
  - MTS testing of resistance tubes
  - Usability survey

## Acknowledgements

We would like to thank the following for making this project possible:

- Dr. Chris Vandivort
- Dr. John Puccinelli
- Dr. Christa Wille
- UW-Madison BME Faculty and Staff

## References

- E. Davis, PhD, private communication, Sept. 2019.
- Avolio, J. (2019). How to Prevent and Treat Rock Climber's Elbow. [online] Mojo Gear. Available at: <https://mojogear.com/journal/2014/04/01/got-elbows-a-guide-to-coping-with-climbers-elbow/> [Accessed 7 Sep. 2019].
- Edwards, A. and Evans, K. (2019). Stretches to Avoid Elbow Pain from Climbing - Gripped Magazine. [online] Gripped Magazine.
- TeachMe Series, Left Forearm. 2020.
- Vive Health, Hangboard. 2020.
- Handmaster Plus, Handmaster Plus. 2020 a.
- Vive Health, Finger Exerciser. 2020.
- DNQDJ. (2019). Height Percentile Calculator by Gender (United States). [online]. Available at: <https://www.dnqdj.com/height-percentile-calculator-for-men-and-women/> [Accessed 8 Oct. 2019].
- ASTM F2276 - 10(2015). ASTM International - Standards Worldwide. 2015. [Online]. Available: <https://www.astm.org/Standards/F2276.htm> [Accessed: 18-Sep-2019].

# CLIMBER'S FOREARM TRAINER

## Testing and Results

### FEA of Base Design

- Base design will withstand the stress of the bands
- Maximum deflection of 2.86 mm

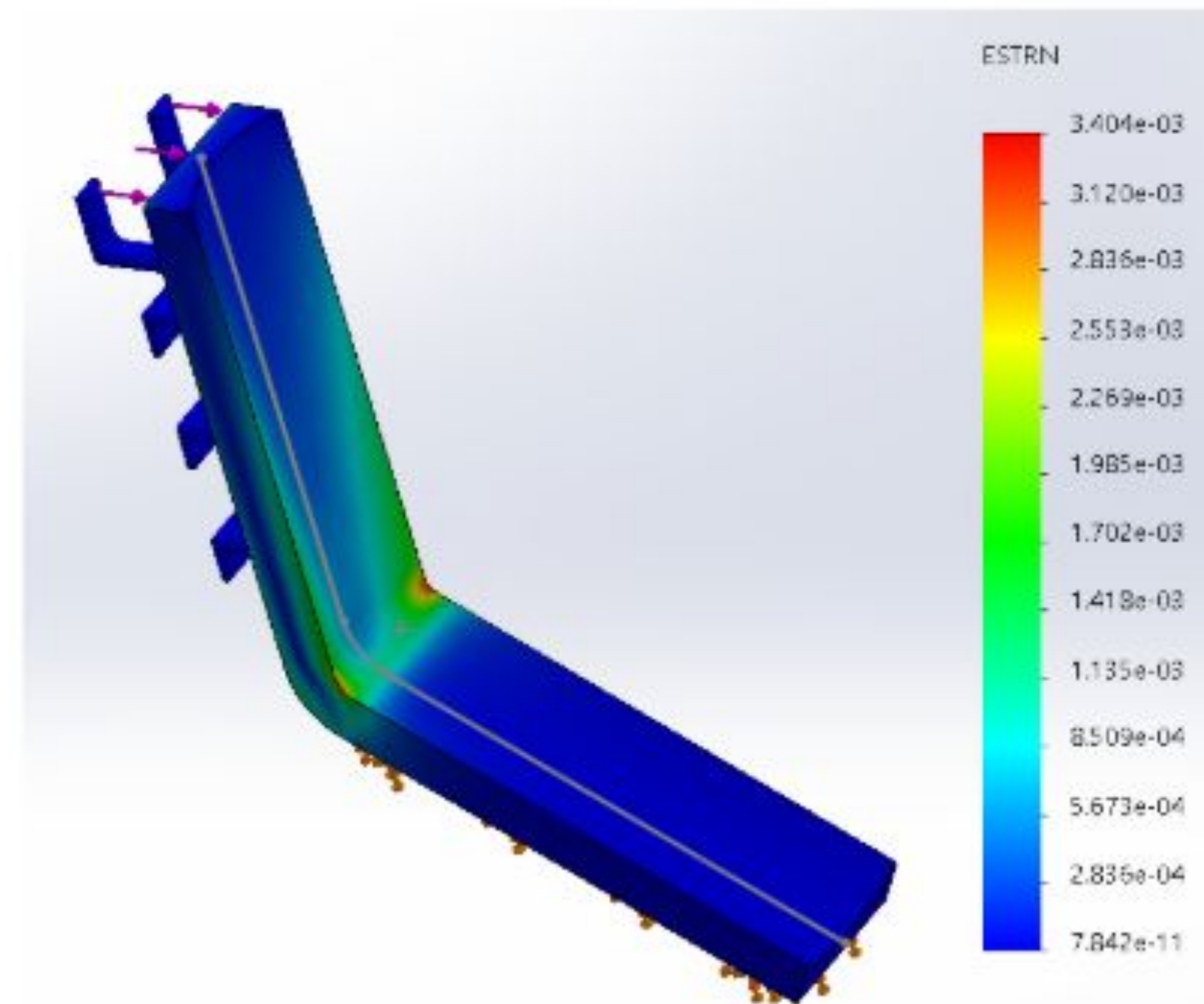

Figure 5: Strain representation of base design under resistance band load

### FEA of Handle Design

- Handle design will withstand the stress of the bands
- Maximum deflection of  $3.57 \times 10^{-4}$  mm.

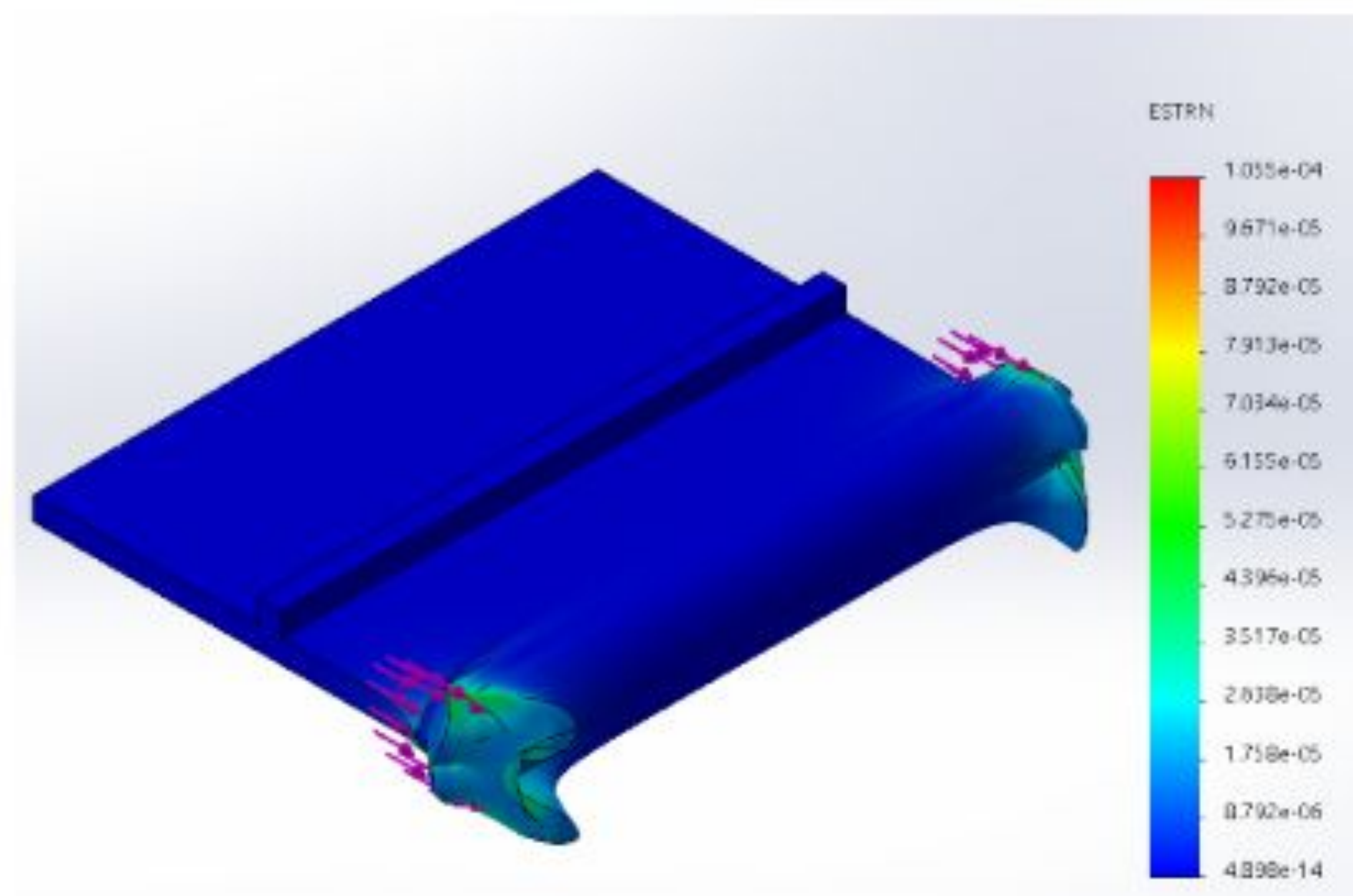

Figure 6: Strain representation of handle design under resistance band load

### Conclusion

- Full design has the ability to withstand the force exerted by the bands.



# CLIMBER'S FOREARM TRAINER



Team Members: Brittany Glaeser, Kaitlin Lacy, Marissa Harkness, Zoe Schmanski, Jonathon Murphy  
 Client: Dr. Chris Vandivort  
 Advisor: Dr. John Puccinelli



College of Engineering  
 UNIVERSITY OF WISCONSIN-MADISON

College of Engineering  
 UNIVERSITY OF WISCONSIN-MADISON

## Abstract

"Climber's Elbow" is a condition experienced by many climbers where the tendon between the forearm flexors and medial epicondyle of the elbow develops microtears. The Forearm Trainer was designed to aid in prevention and rehabilitation of Climber's Elbow. The device includes variable resistances and a grip strengthener handle. The portable device strengthens the flexors and extensors as well as pronators and supinators of the forearm.

## Motivation

Climber's Elbow, also known as Medial Epicondylitis, affects many rock climbers and can be treated through resistance training of the forearm flexors and extensors. A portable device can help aid in the prevention and rehabilitation of this condition.

## Background

- 4 major forearm muscles [1]
- Pronator teres is the muscle of focus
- Movements:
  - Pronation of hand
  - Flexing of the elbow
- Medial Epicondylitis / "Climber's Elbow"
  - Micro-tearing of the pronator teres [2]
  - overuse of the tendon without sufficient recovery
  - Imbalance in strength of flexor muscles versus the extensor muscles = excessive strain [3]

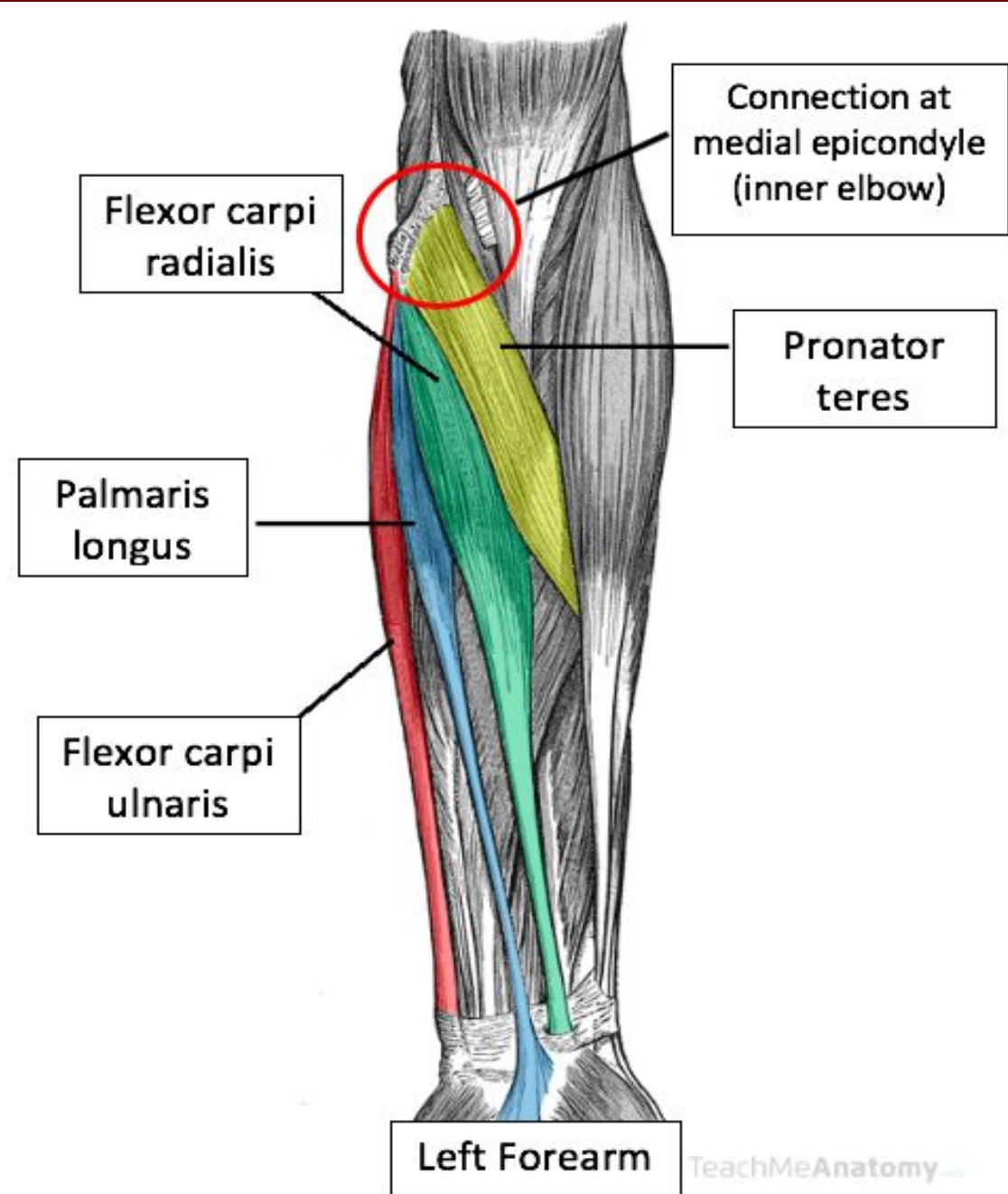

Figure 1: The 4 main muscle groups attached at the medial epicondyle [4]

### Current Devices



Figure 2: Hangboard [5]

Figure 3: Vive Health Finger Exerciser [7]

Figure 4: Handmaster Plus [6]

## Design Criteria

- Effectively targets forearm muscles
- Variable resistances of 5-30 lbs
  - Average forearm length of 23.1 - 26.4 cm
  - Average upper arm length of 29.2 - 33.4 cm [8]
- Durable to withstand daily use for many years
  - Five to ten years for plastic pieces and straps
- Includes grip strengthening component
- Follows ASTM Standards of Fitness [9]
- Easy to use, safe, comfortable, portable and low cost

## Materials

- 3D print - PLA
- Rollerblade straps
- Sponge foam padding
- Flex seal
- Resistance bands
- Carabiners
- 1" Nylon straps
- Hook eye screws
- 0.25" Eyelets
- Brass knurled inserts

Total Costs: \$120.93

## Testing and Results

### FEA of Base Design

- Base design will withstand the stress of the bands
- Maximum deflection of 2.86 mm

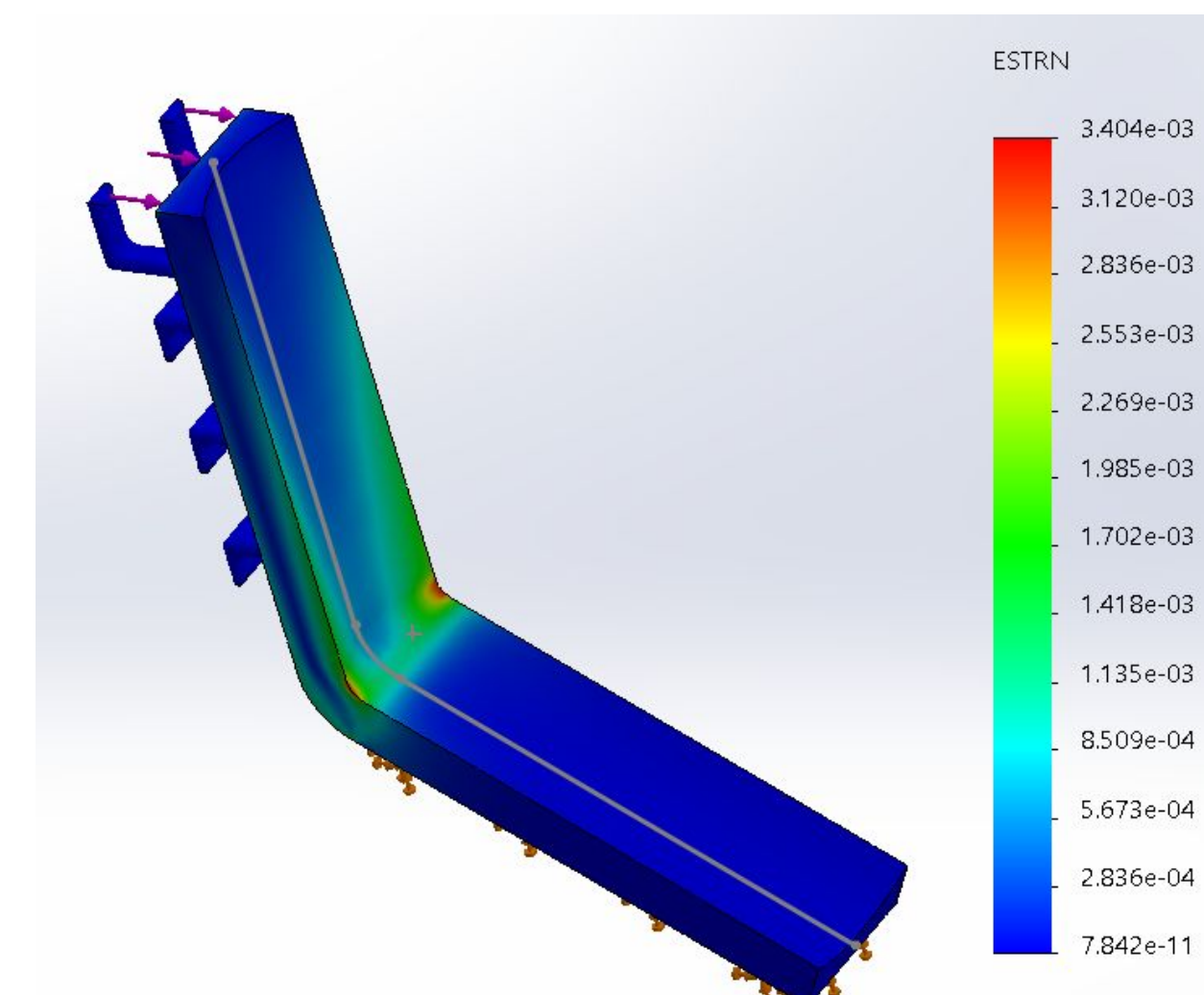

Figure 5: Strain representation of base design under resistance band load

### FEA of Handle Design

- Handle design will withstand the stress of the bands
- Maximum deflection of  $3.57 \times 10^{-4}$  mm.

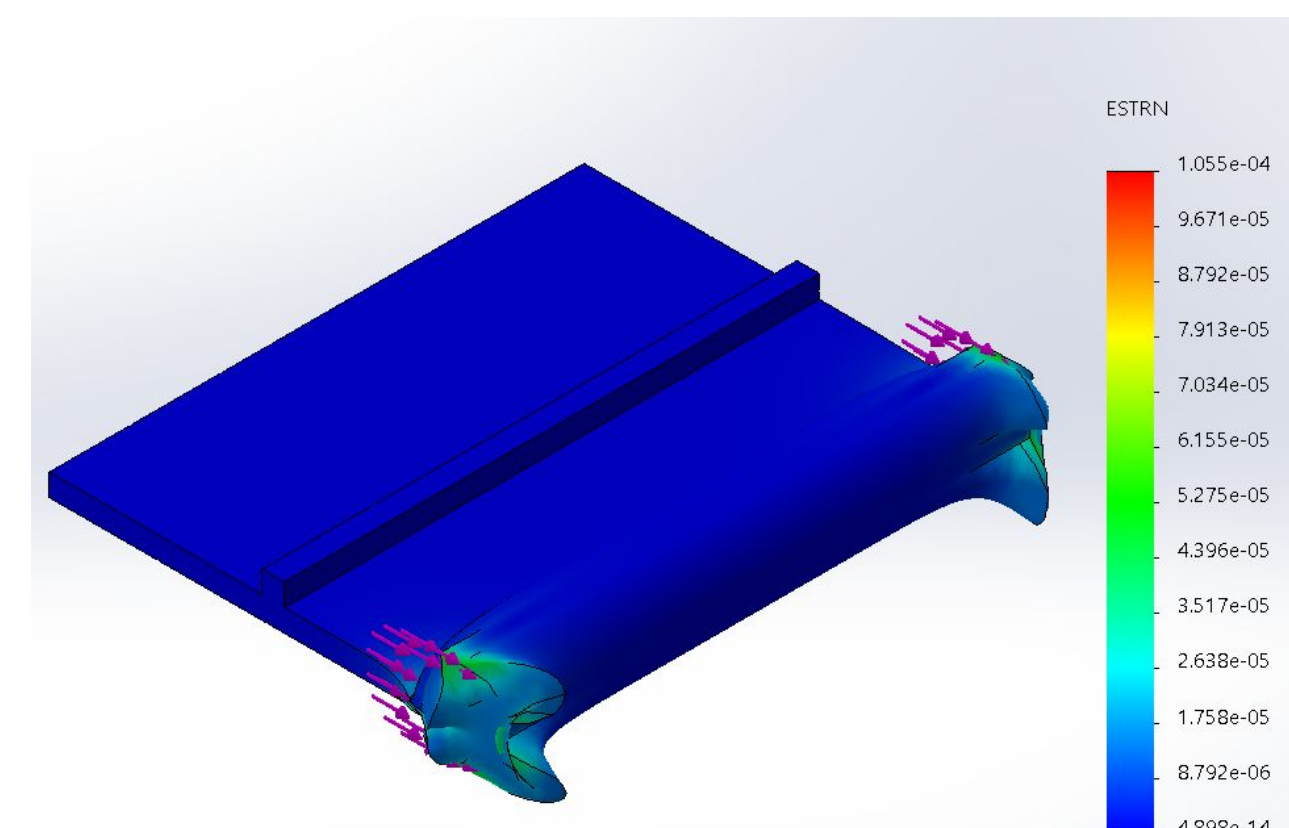

Figure 6: Strain representation of handle design under resistance band load

### Conclusion

- Full design has the ability to withstand the force exerted by the bands.

## Final Design



Figure 7: Original design with updated resistance bands

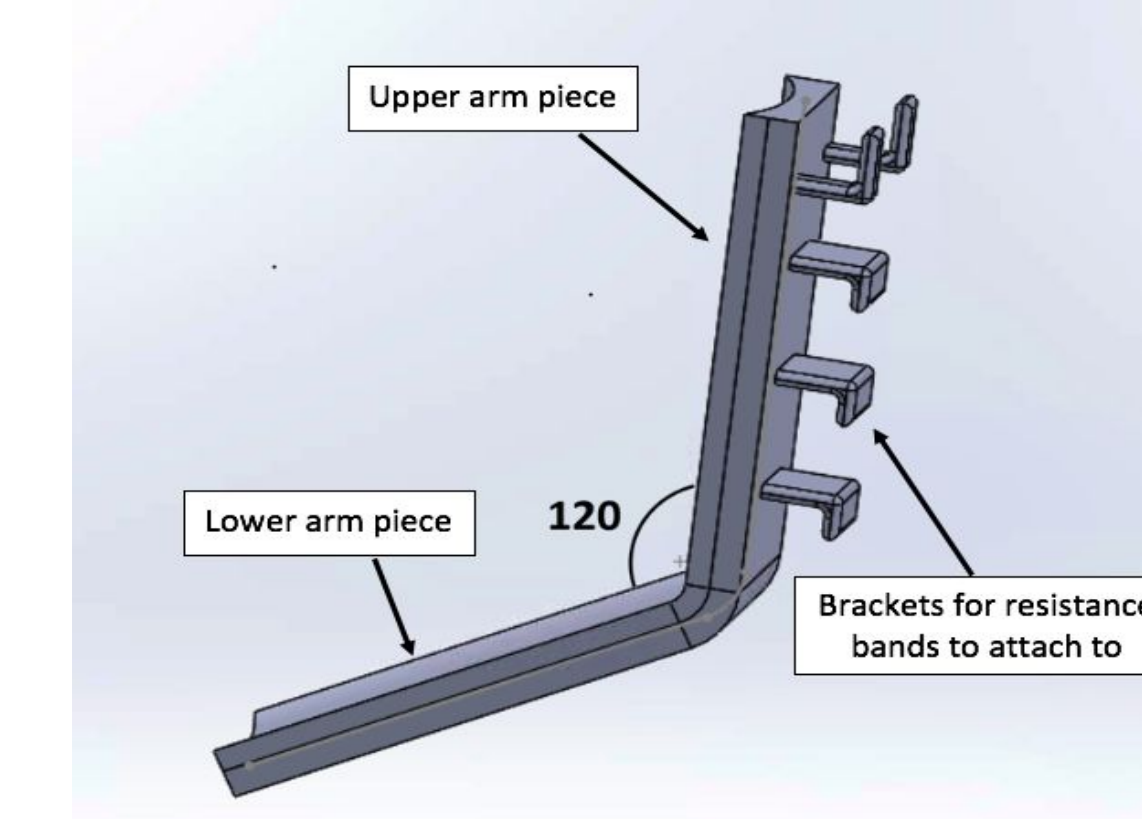

Figure 8: Proposed design of back piece

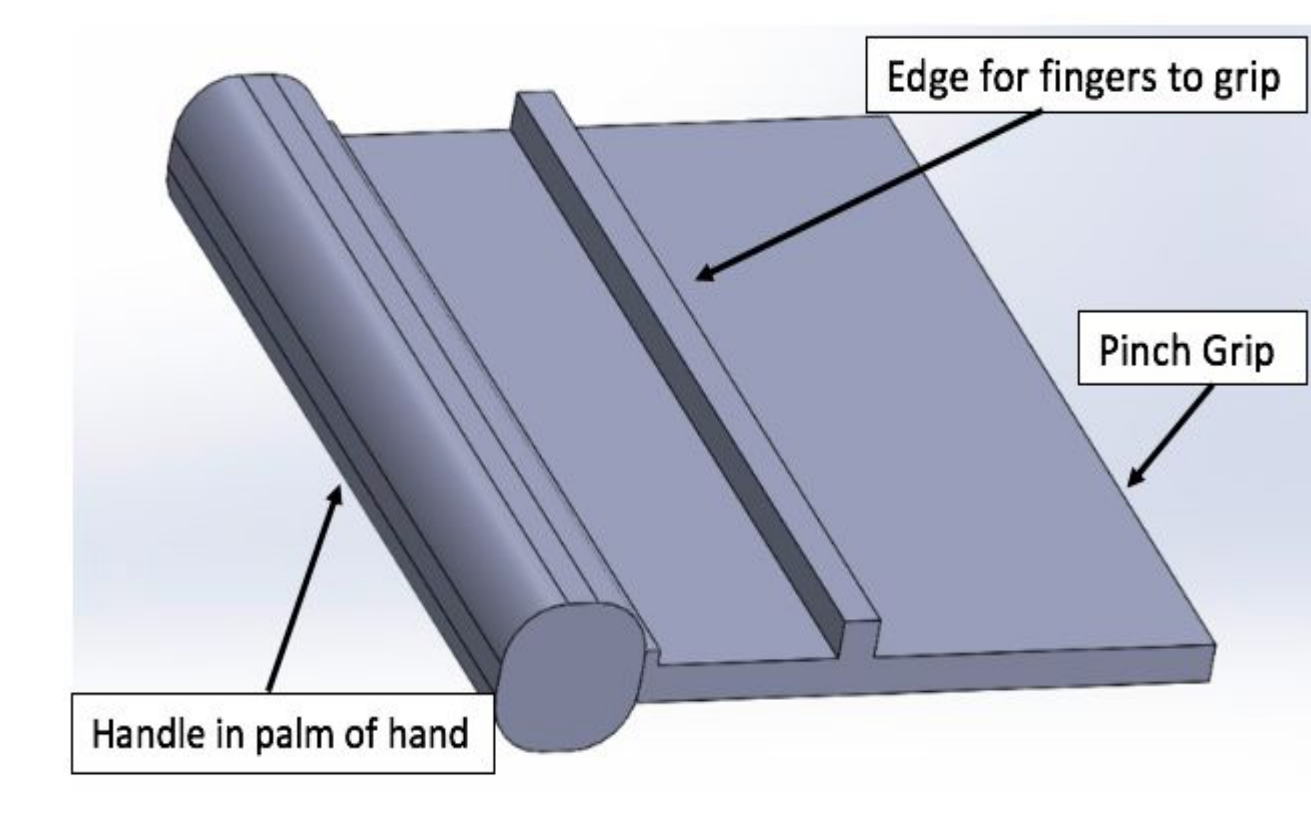

Figure 9: Proposed handle design for grip strengthening

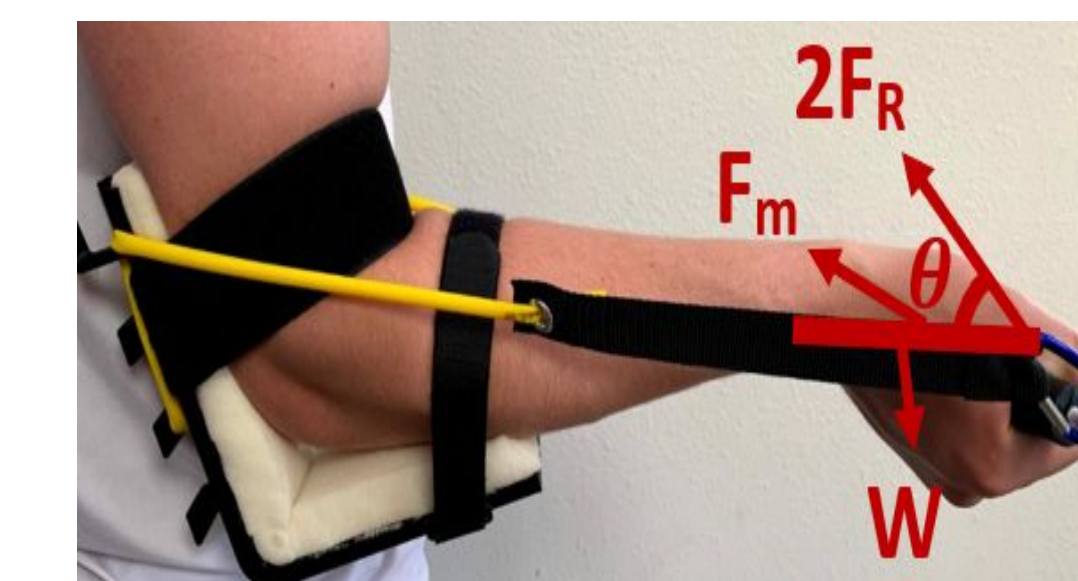

Figure 10: FBD for the extensors and flexors

$$F_m = \frac{L \cdot 2F_R \sin \theta - W \cdot d_w}{MA}$$

$$F_m = \frac{2F_R \sin \theta}{MA}$$

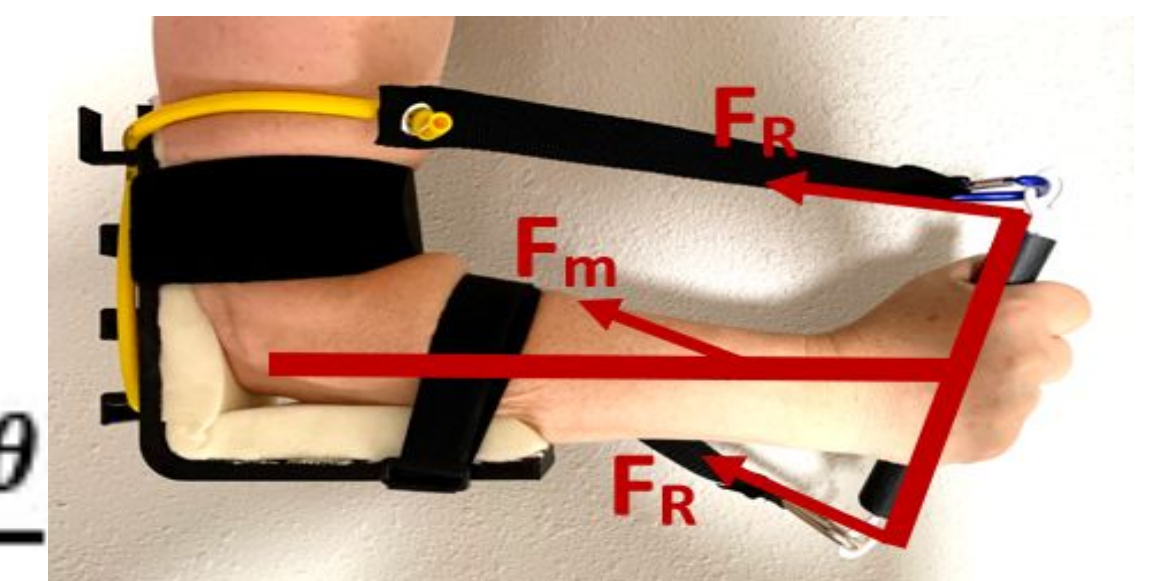

Figure 11: FBD for the pronator teres



Figure 12: Forearm motions used with the device. Shown is the original design with updated resistance bands.

## Future Work

- Tightening mechanism for straps
  - A tension lock similar to those on backpack
- Injection Molding
  - Considered as a mode of fabrication for final prototype after CAD designs are finalized
  - Protolabs Manufacturing
- Removable pinch grip feature
- Testing
  - EMG to confirm isolation of forearm muscles from bicep
  - MTS testing of resistance tubes
  - Usability survey

## Acknowledgements

We would like to thank the following for making this project possible:

- Dr. Chris Vandivort
- Dr. John Puccinelli
- Dr. Christa Wille
- UW-Madison BME Faculty and Staff

## References

- E. Davis, PhD, private communication, Sept. 2019.
- Avonit, I. (2019). How to Prevent and Treat Rock Climber's Elbow. [online] Mojo Gear. Available at: <https://mojogear.com/journal/2014/04/01/got-elbows-a-guide-to-coping-with-climbers-elbow/> [Accessed 7 Sep. 2019].
- Edwards, A. and Evans, K. (2019). Stretches to Avoid Elbow Pain from Climbing - Gripped Magazine. [online] Gripped Magazine.
- TeachMe Series, Left Forearm. 2020.
- Vive Health. 2020.
- Handmaster Plus, Handmaster Plus. 2020 a.
- Vive Health, Finger Exerciser. 2020.
- DNQDJ. (2019). Height Percentile Calculator by Gender (United States). [online]. Available at: <https://www.dnqdj.com/height-percentile-calculator-for-men-and-women/> [Accessed 8 Oct. 2019].
- ASTM F2276 - 10(2015). ASTM International - Standards Worldwide. 2015. [Online]. Available: <https://www.astm.org/Standards/F2276.htm> [Accessed: 18-Sep-2019].

# CLIMBER'S FOREARM TRAINER

## Final Design



Figure 7: Original design with updated resistance bands

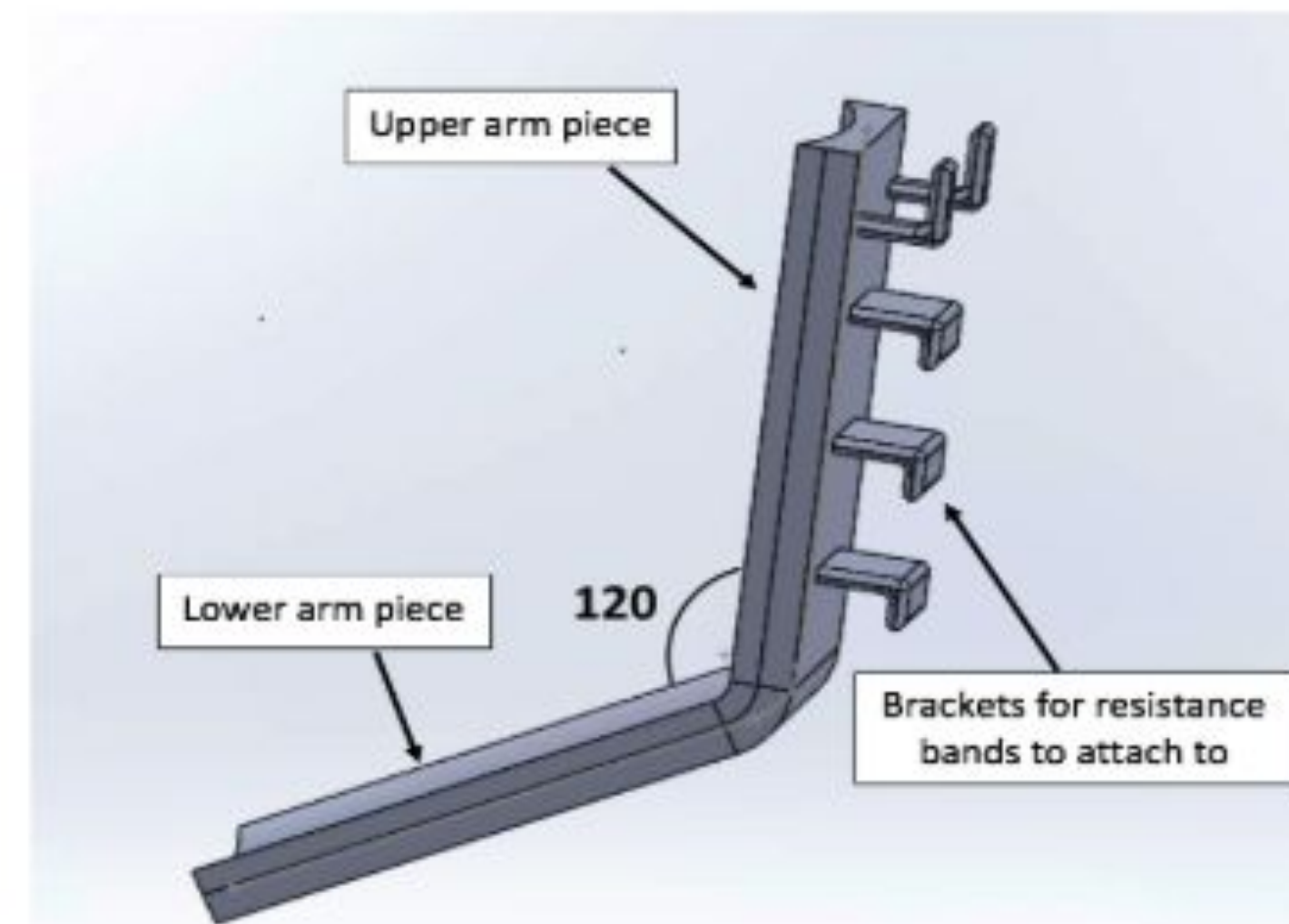

Figure 8: Proposed design of back piece

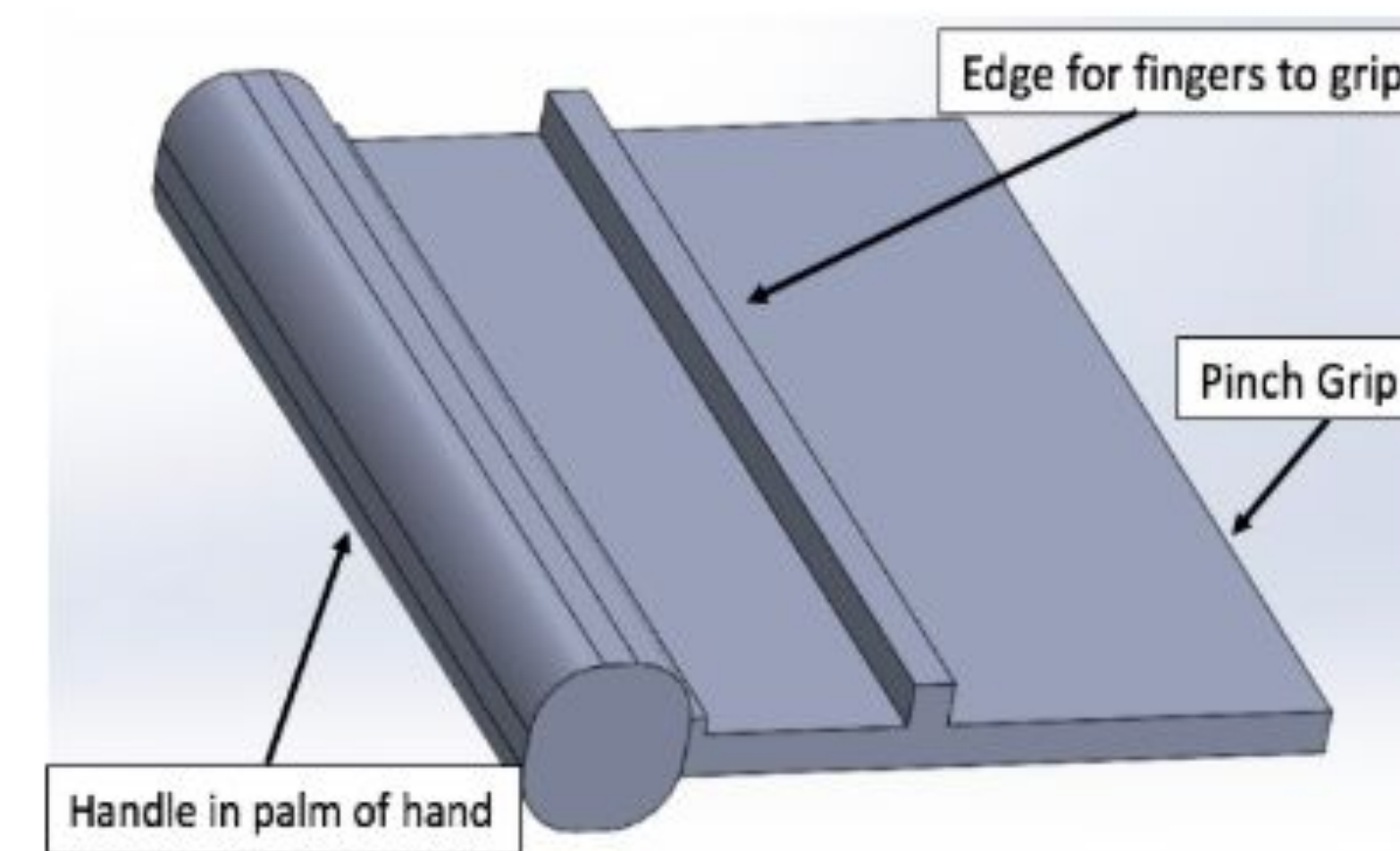

Figure 9: Proposed handle design for grip strengthening

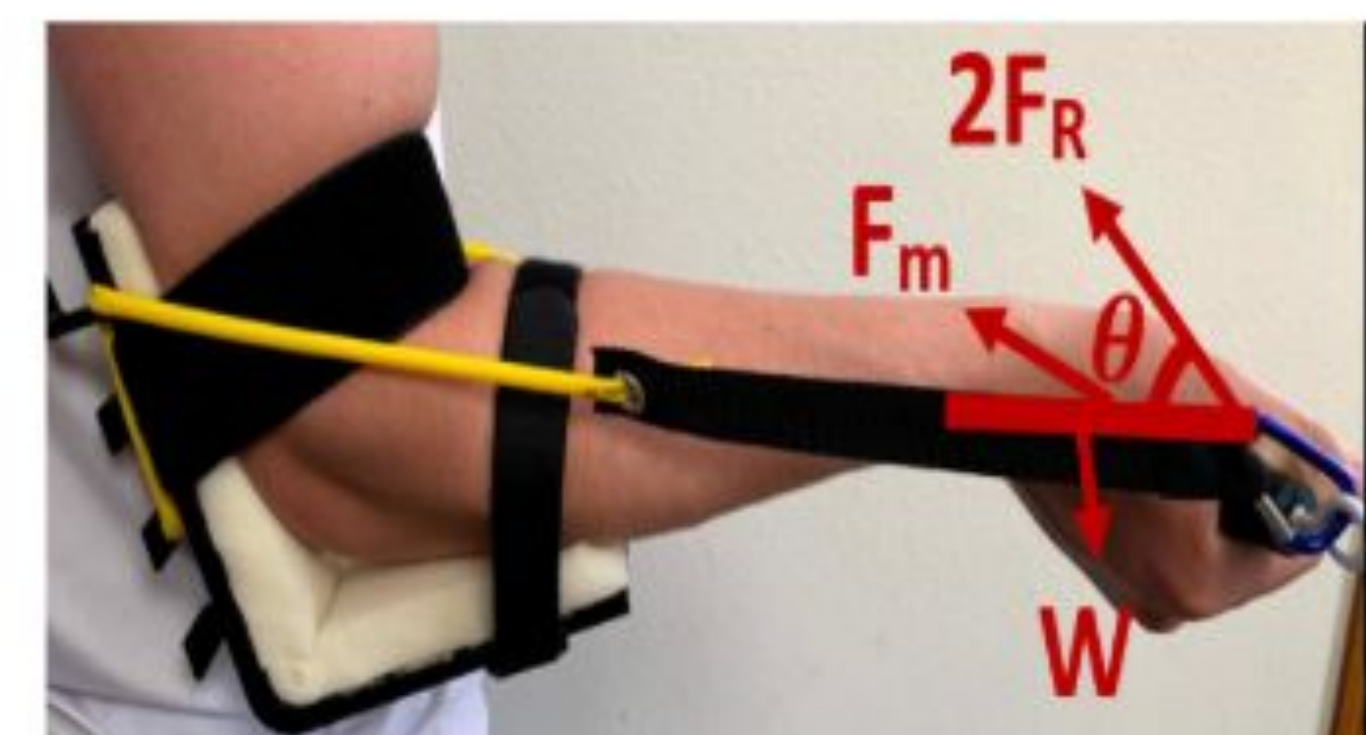

Figure 10: FBD for the extensors and flexors

$$F_m = \frac{L \cdot 2F_R \sin \theta - W \cdot d_w}{MA}$$

$$F_m = \frac{2F_R \sin \theta}{MA}$$

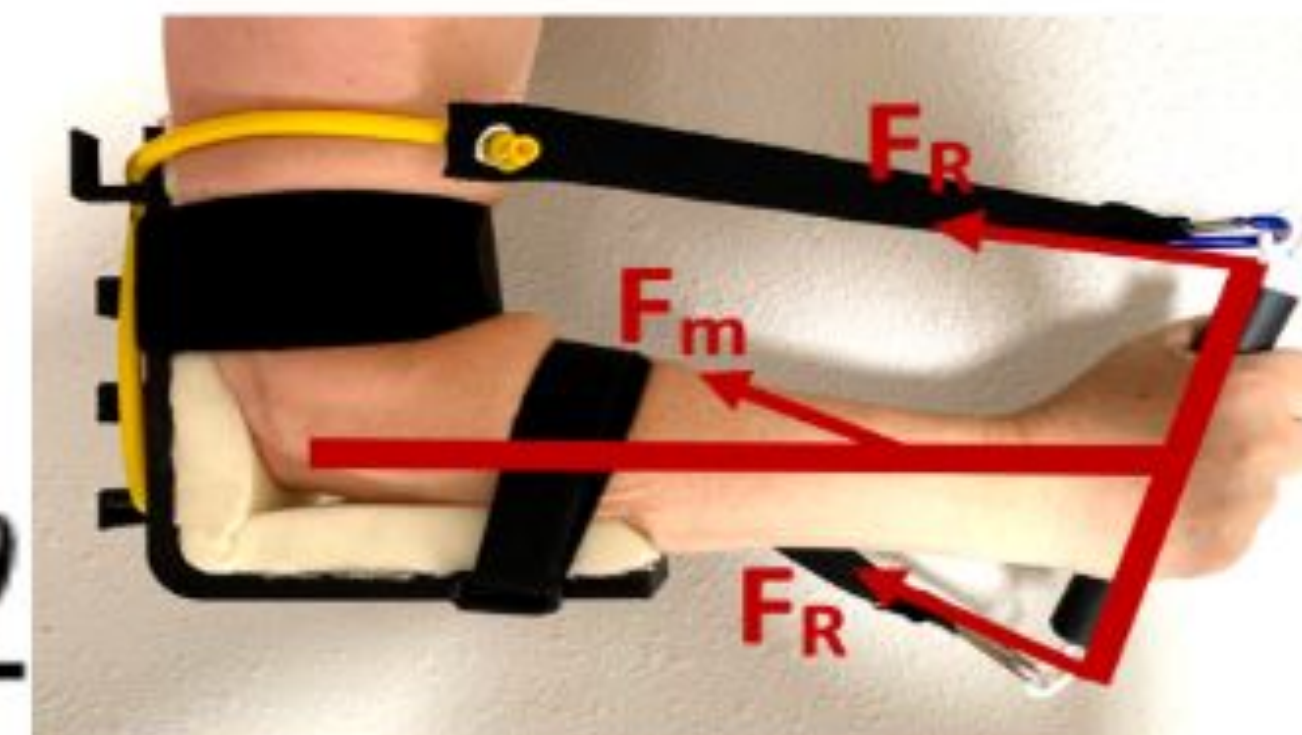

Figure 11: FBD for the pronator teres



# CLIMBER'S FOREARM TRAINER



Team Members: Brittany Glaeser, Kaitlin Lacy, Marissa Harkness, Zoe Schmanski, Jonathon Murphy  
 Client: Dr. Chris Vandivort  
 Advisor: Dr. John Puccinelli



College of Engineering  
 UNIVERSITY OF WISCONSIN-MADISON

College of Engineering  
 UNIVERSITY OF WISCONSIN-MADISON

## Abstract

“Climber’s Elbow” is a condition experienced by many climbers where the tendon between the forearm flexors and medial epicondyle of the elbow develops microtears. The Forearm Trainer was designed to aid in prevention and rehabilitation of Climber’s Elbow. The device includes variable resistances and a grip strengthener handle. The portable device strengthens the flexors and extensors as well as pronators and supinators of the forearm.

## Motivation

Climber’s Elbow, also known as Medial Epicondylitis, affects many rock climbers and can be treated through resistance training of the forearm flexors and extensors. A portable device can help aid in the prevention and rehabilitation of this condition.

## Background

- 4 major forearm muscles [1]
- Pronator teres is the muscle of focus
- Movements:  
 Pronation of hand  
 Flexing of the elbow
- Medial Epicondylitis / “Climber’s Elbow”
  - Micro-tearing of the pronator teres [2]
  - overuse of the tendon without sufficient recovery
  - Imbalance in strength of flexor muscles versus the extensor muscles = excessive strain [3]

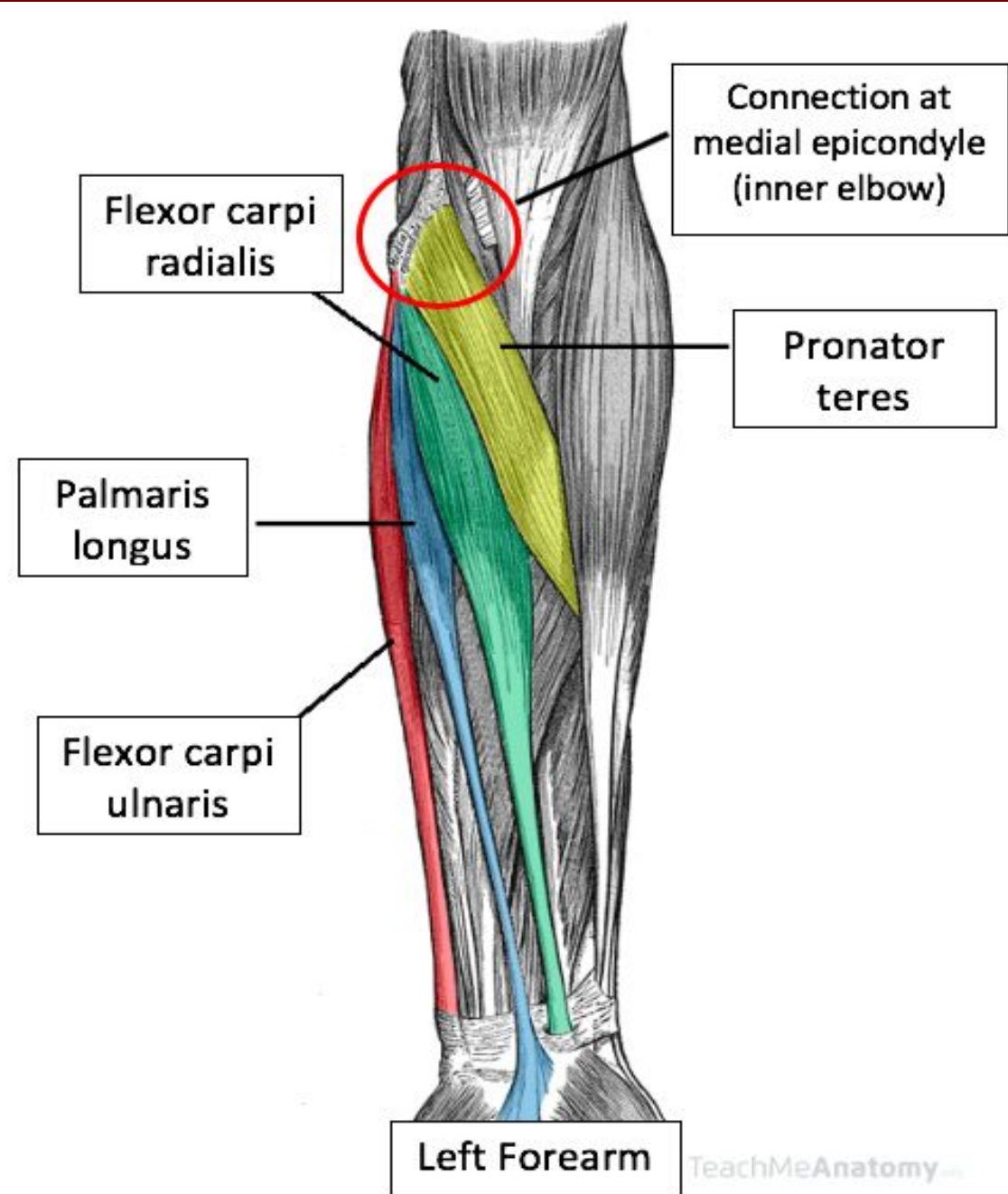

Figure 1: The 4 main muscle groups attached at the medial epicondyle [4]

### Current Devices



Figure 2: Hangboard [5]

Figure 3: Vive Health Finger Exerciser [7]

Figure 4: Handmaster Plus [6]

## Design Criteria

- Effectively targets forearm muscles
- Variable resistances of 5-30 lbs
  - Average forearm length of 23.1 - 26.4 cm
  - Average upper arm length of 29.2 - 33.4 cm [8]
- Durable to withstand daily use for many years
  - Five to ten years for plastic pieces and straps
- Includes grip strengthening component
- Follows ASTM Standards of Fitness [9]
- Easy to use, safe, comfortable, portable and low cost

## Materials

- 3D print - PLA
- Rollerblade straps
- Sponge foam padding
- Flex seal
- Resistance bands
- Carabiners
- 1” Nylon straps
- Hook eye screws
- 0.25” Eyelets
- Brass knurled inserts

Total Costs: \$120.93

## Testing and Results

### FEA of Base Design

- Base design will withstand the stress of the bands
- Maximum deflection of 2.86 mm

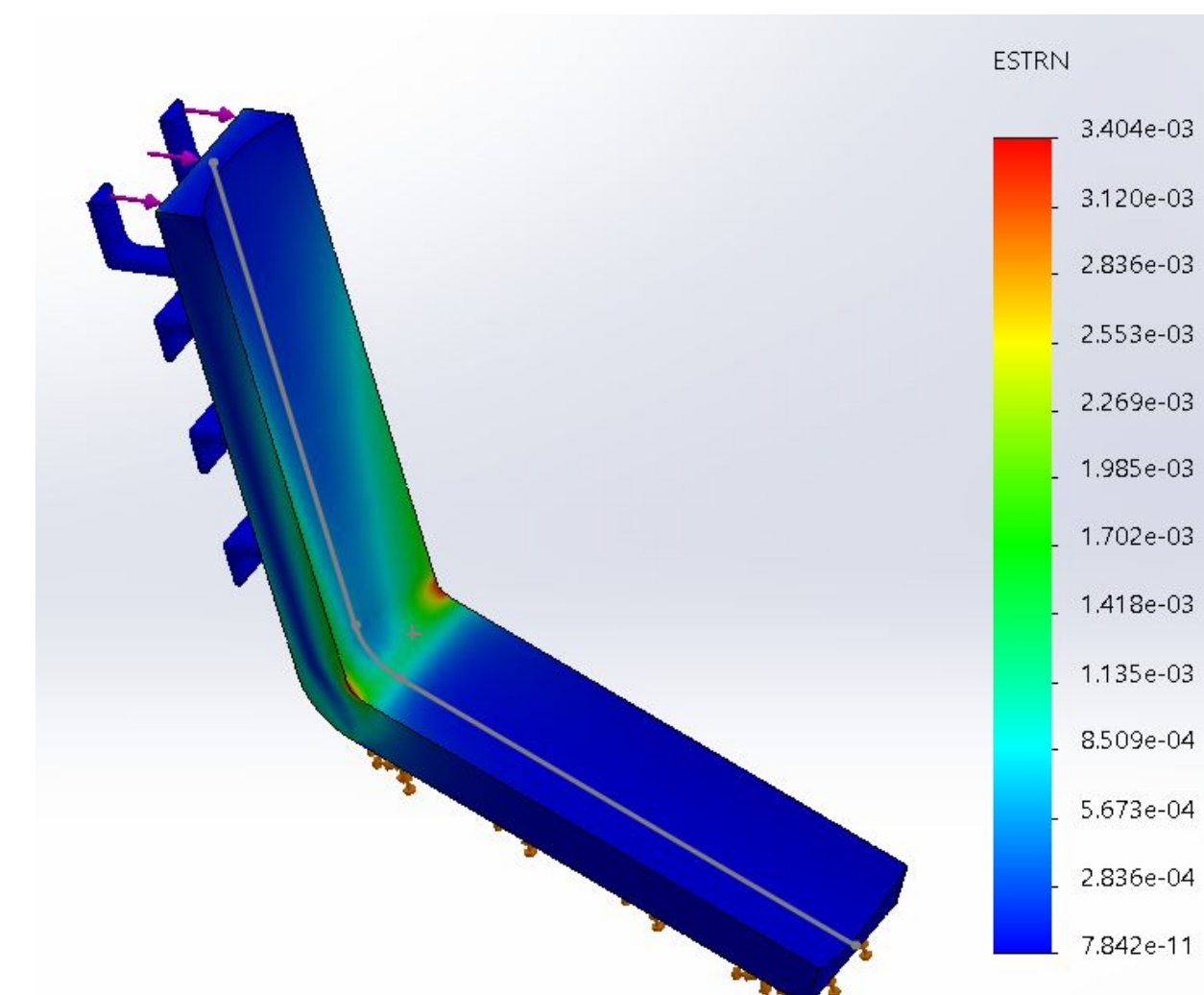

Figure 5: Strain representation of base design under resistance band load

### FEA of Handle Design

- Handle design will withstand the stress of the bands
- Maximum deflection of  $3.57 \times 10^{-4}$  mm.

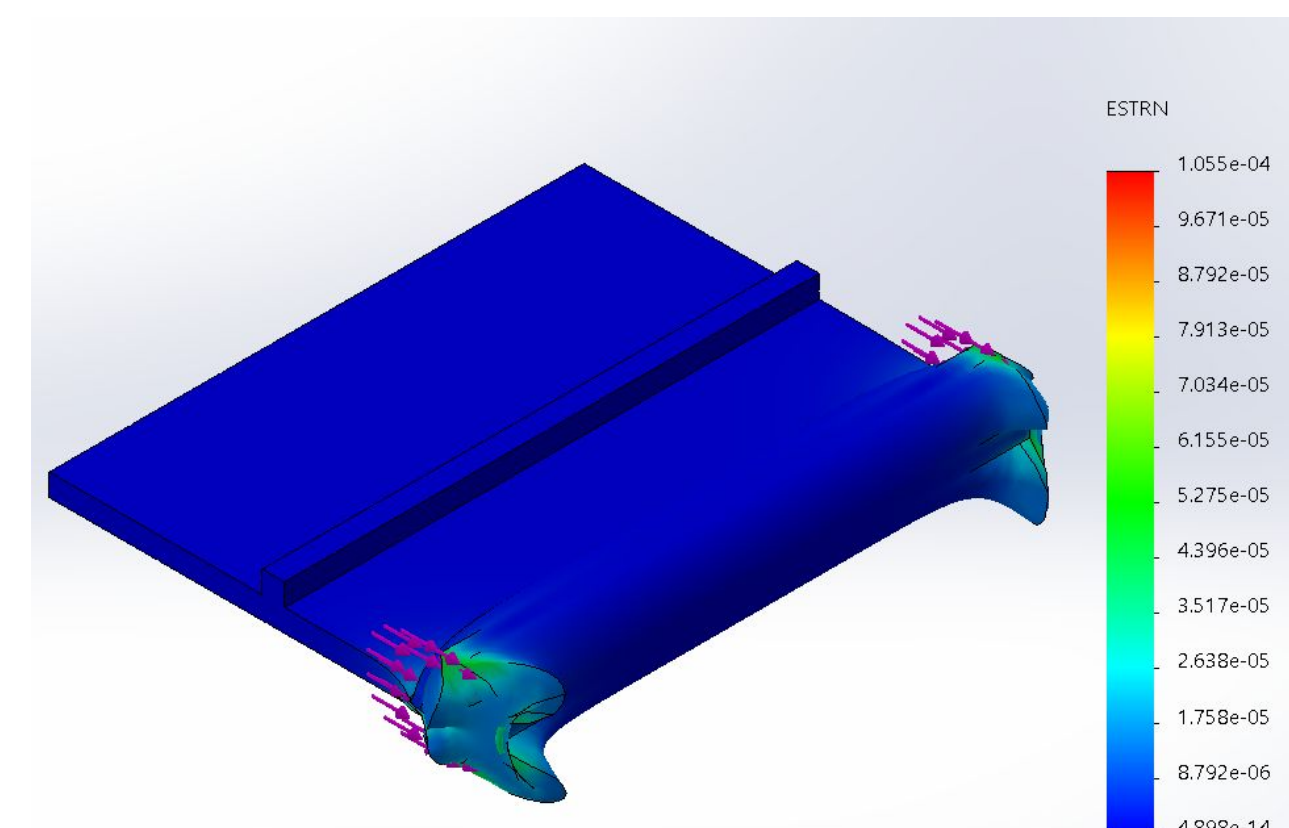

Figure 6: Strain representation of handle design under resistance band load

### Conclusion

- Full design has the ability to withstand the force exerted by the bands.

## Final Design



Figure 7: Original design with updated resistance bands

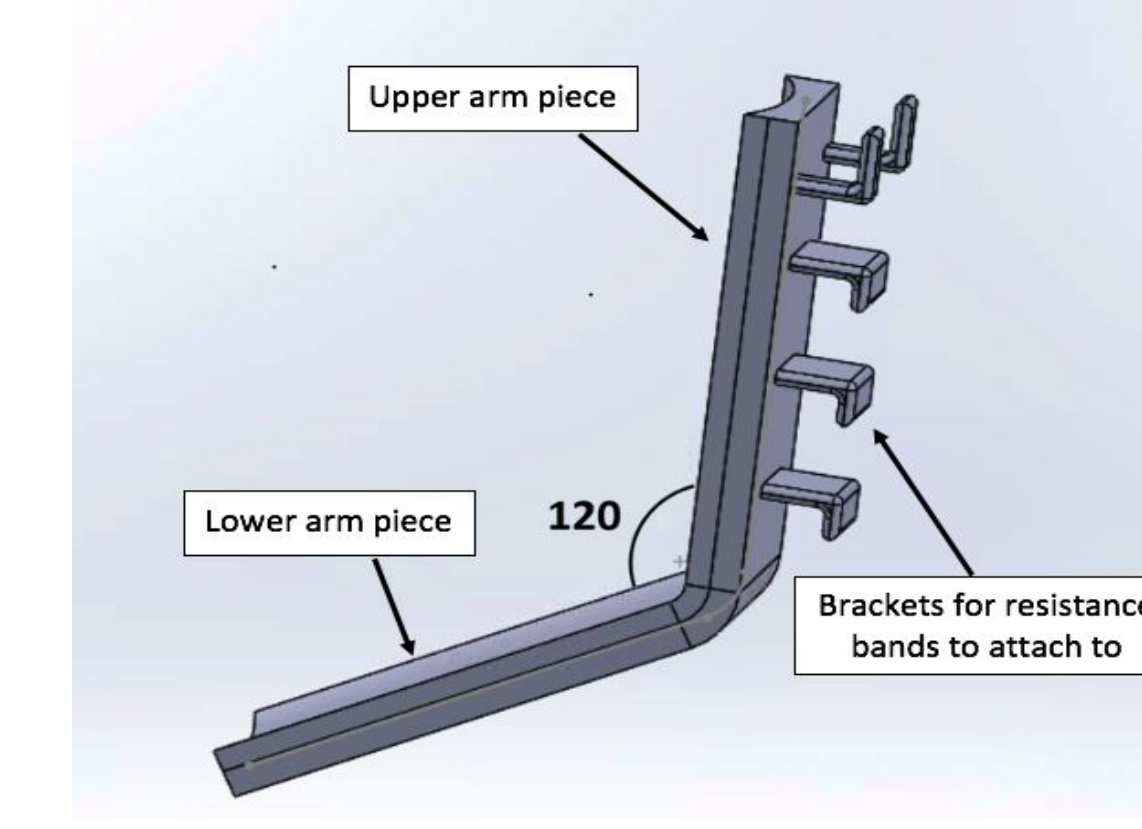

Figure 8: Proposed design of back piece

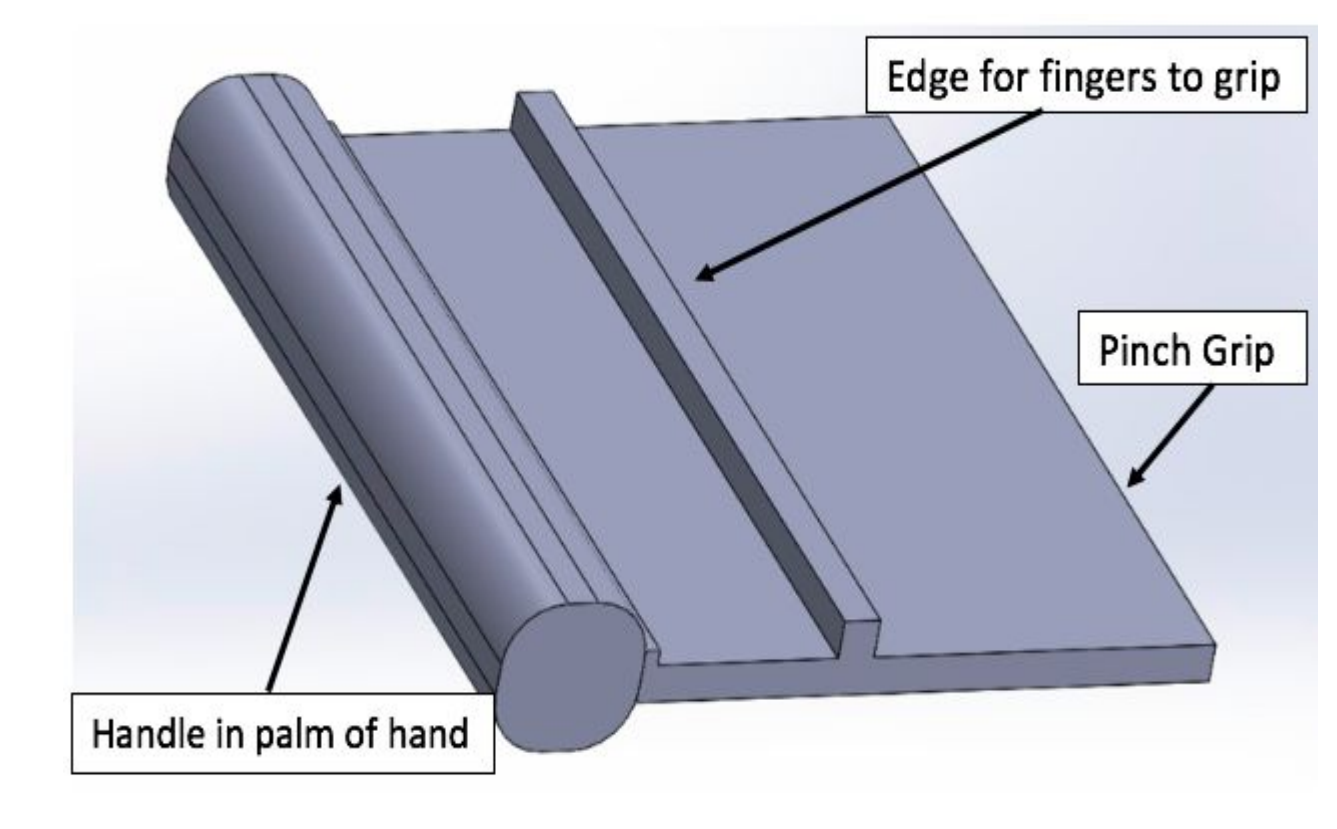

Figure 9: Proposed handle design for grip strengthening

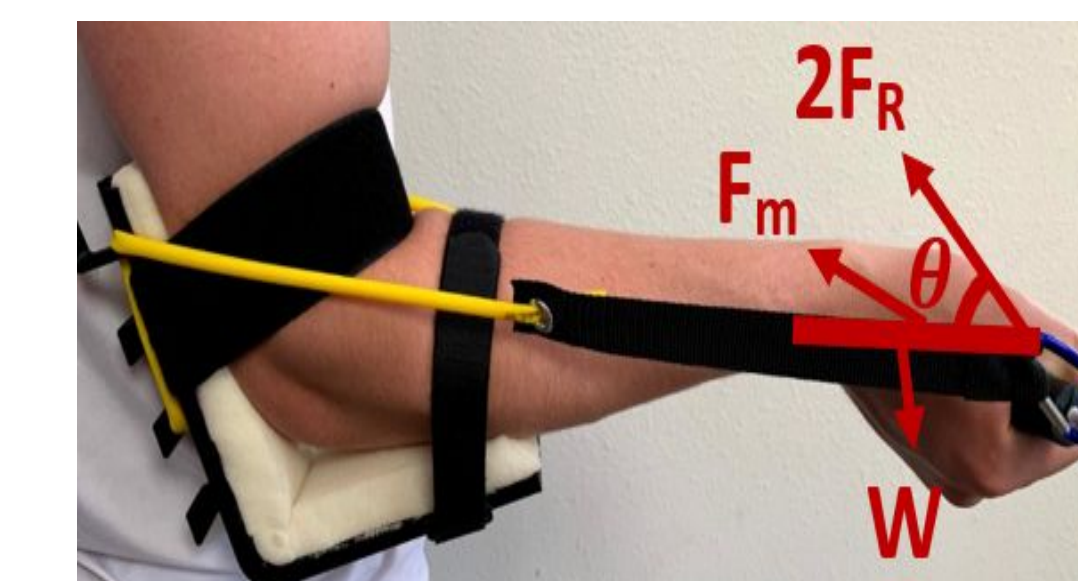

Figure 10: FBD for the extensors and flexors

$$F_m = \frac{L \cdot 2F_R \sin \theta - W \cdot d_w}{MA}$$

$$F_m = \frac{2F_R \sin \theta}{MA}$$

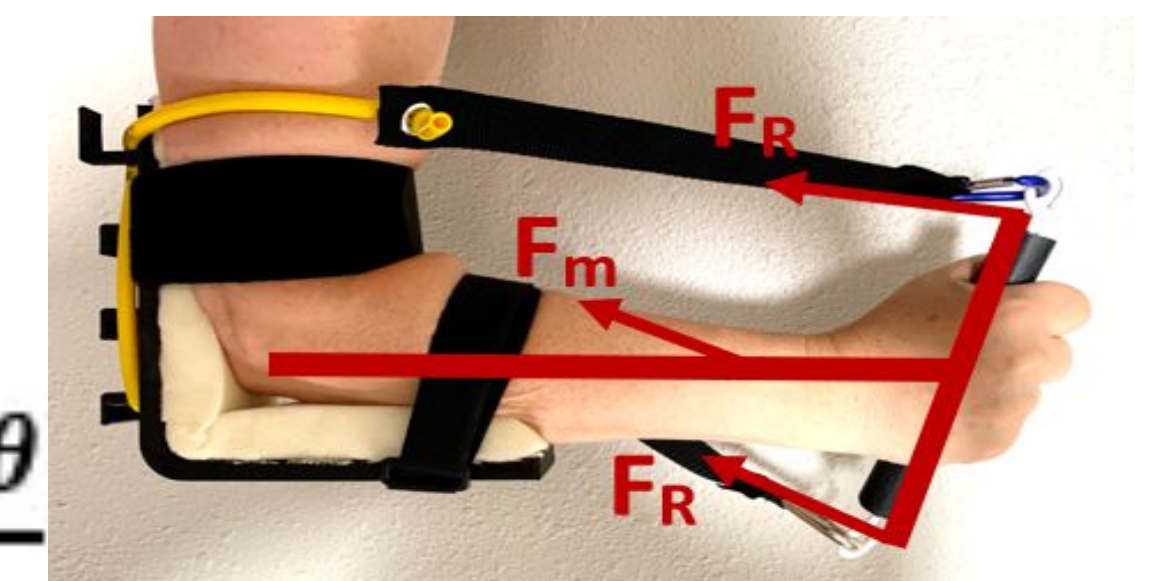

Figure 11: FBD for the pronator teres



Figure 12: Forearm motions used with the device. Shown is the original design with updated resistance bands.

## Future Work

- Tightening mechanism for straps
  - A tension lock similar to those on backpack
- Injection Molding
  - Considered as a mode of fabrication for final prototype after CAD designs are finalized
  - Protolabs Manufacturing
- Removable pinch grip feature
- Testing
  - EMG to confirm isolation of forearm muscles from bicep
  - MTS testing of resistance tubes
  - Usability survey

## Acknowledgements

We would like to thank the following for making this project possible:

- Dr. Chris Vandivort
- Dr. John Puccinelli
- Dr. Christa Wille
- UW-Madison BME Faculty and Staff

## References

- [1] E. Davis, PhD, private communication, Sept. 2019.
- [2] Avouf, I. (2019). How to Prevent and Treat Rock Climber's Elbow. [online] Mojo Gear. Available at: https://mojogear.com/journal/2014/04/01/got-elbows-a-guide-to-coping-with-climbers-elbow/ [Accessed 7 Sep. 2019].
- [3] Edwards, A. and Evans, K. (2019). Stretches to Avoid Elbow Pain from Climbing - Gripped Magazine. [online] Gripped Magazine.
- [4] TestMile Series, Left Forearm. 2020.
- [5] Vive Health. 2020.
- [6] Handmaster Plus, Handmaster Plus. 2020 a.
- [7] Vive Health, Finger Exerciser. 2020.
- [8] DNDJ. (2019). Height Percentile Calculator by Gender (United States). [online]. Available at: https://www.dndj.com/height-percentile-calculator-for-men-and-women/ [Accessed 8 Oct. 2019].
- [9] ASTM F2276 - 10(2015). ASTM International - Standards Worldwide. 2015. [Online]. Available: https://www.astm.org/Standards/F2276.htm. [Accessed: 18-Sep-2019].

# CLIMBER'S FOREARM TRAINER

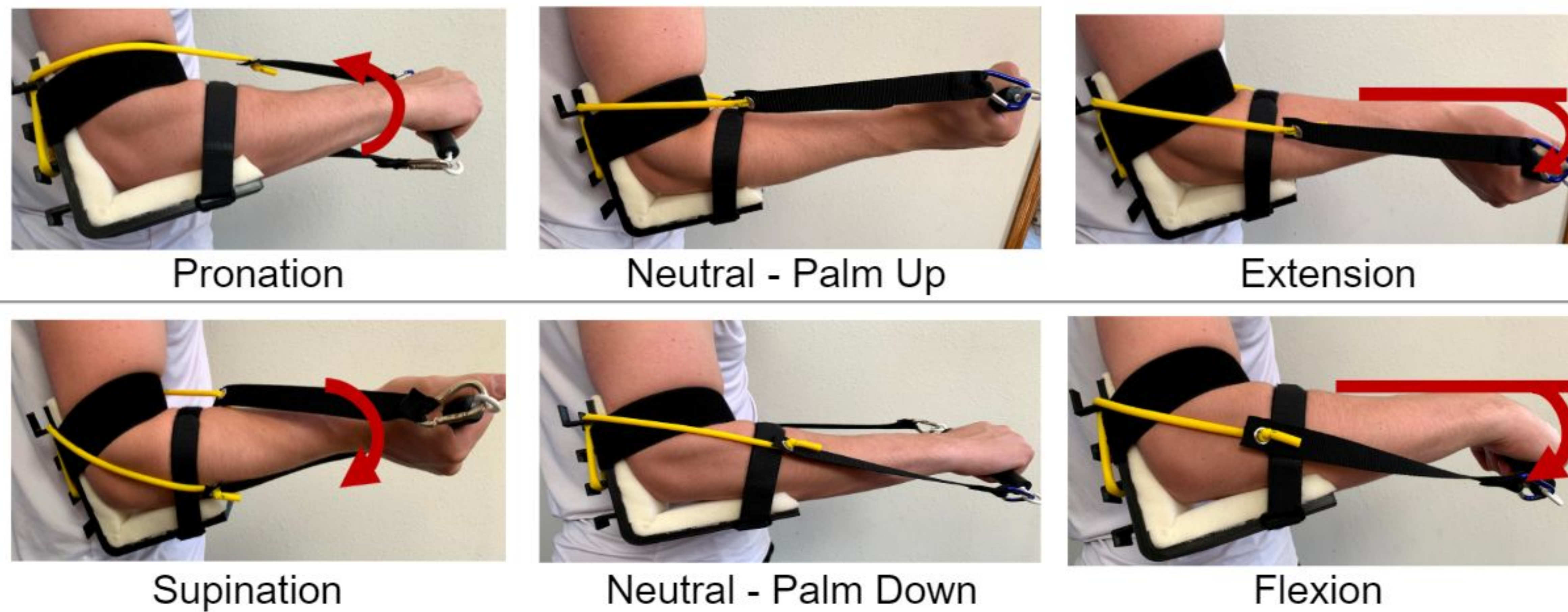

Figure 12: Forearm motions used with the device. Shown is the original design with updated resistance bands.



# CLIMBER'S FOREARM TRAINER



Team Members: Brittany Glaeser, Kaitlin Lacy, Marissa Harkness, Zoe Schmanski, Jonathon Murphy  
 Client: Dr. Chris Vandivort  
 Advisor: Dr. John Puccinelli



College of Engineering  
 UNIVERSITY OF WISCONSIN-MADISON

College of Engineering  
 UNIVERSITY OF WISCONSIN-MADISON

## Abstract

"Climber's Elbow" is a condition experienced by many climbers where the tendon between the forearm flexors and medial epicondyle of the elbow develops microtears. The Forearm Trainer was designed to aid in prevention and rehabilitation of Climber's Elbow. The device includes variable resistances and a grip strengthener handle. The portable device strengthens the flexors and extensors as well as pronators and supinators of the forearm.

## Motivation

Climber's Elbow, also known as Medial Epicondylitis, affects many rock climbers and can be treated through resistance training of the forearm flexors and extensors. A portable device can help aid in the prevention and rehabilitation of this condition.

## Background

- 4 major forearm muscles [1]
- Pronator teres is the muscle of focus
- Movements:
  - Pronation of hand
  - Flexing of the elbow
- Medial Epicondylitis / "Climber's Elbow"
  - Micro-tearing of the pronator teres [2]
  - overuse of the tendon without sufficient recovery
  - Imbalance in strength of flexor muscles versus the extensor muscles = excessive strain [3]

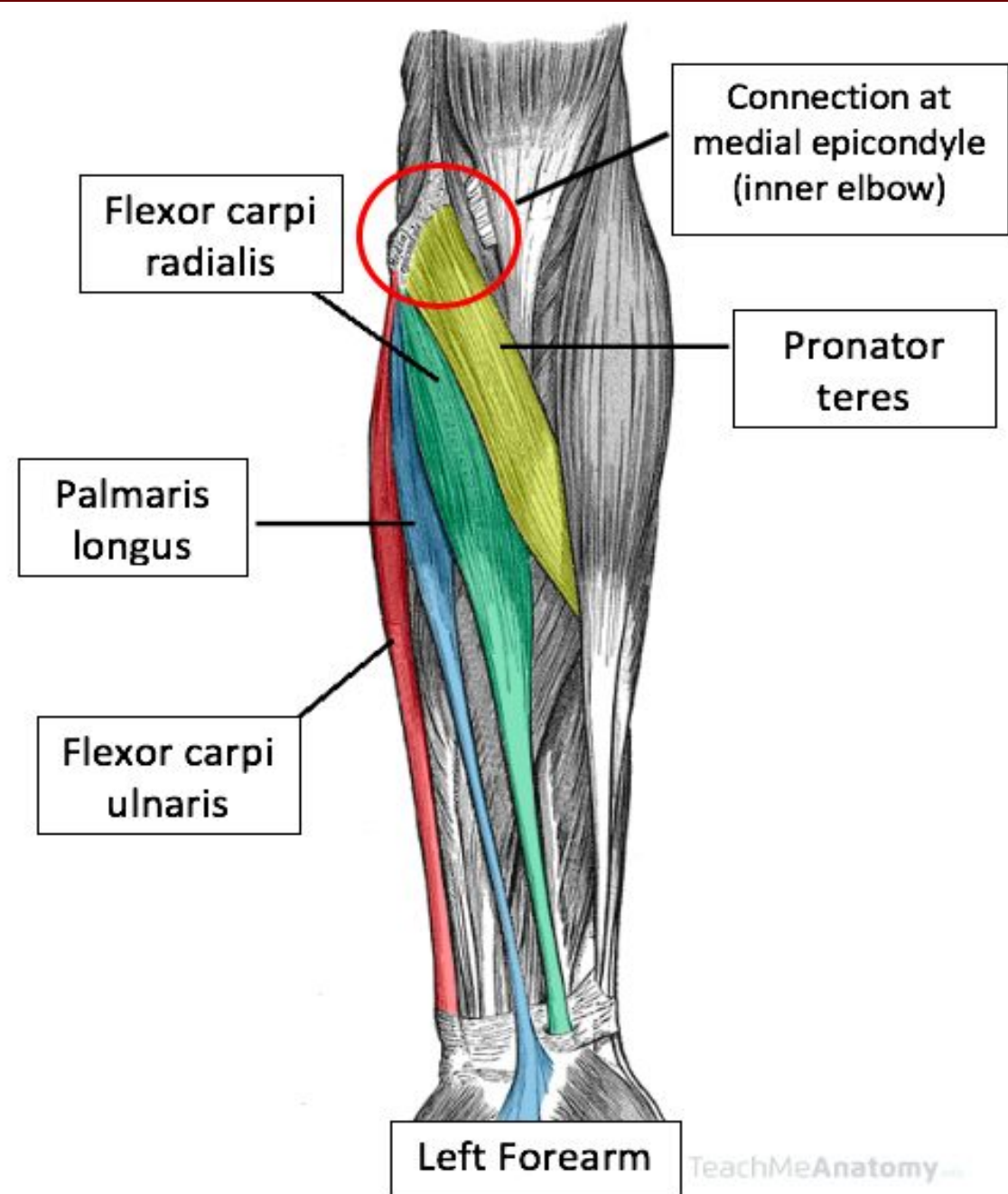

Figure 1: The 4 main muscle groups attached at the medial epicondyle [4]

### Current Devices



Figure 2: Hangboard [5]

Figure 3: Vive Health Finger Exerciser [7]

Figure 4: Handmaster Plus [6]

## Design Criteria

- Effectively targets forearm muscles
- Variable resistances of 5-30 lbs
  - Average forearm length of 23.1 - 26.4 cm
  - Average upper arm length of 29.2 - 33.4 cm [8]
- Durable to withstand daily use for many years
  - Five to ten years for plastic pieces and straps
- Includes grip strengthening component
- Follows ASTM Standards of Fitness [9]
- Easy to use, safe, comfortable, portable and low cost

## Materials

- 3D print - PLA
- Rollerblade straps
- Sponge foam padding
- Flex seal
- Resistance bands
- Carabiners
- 1" Nylon straps
- Hook eye screws
- 0.25" Eyelets
- Brass knurled inserts

Total Costs: \$120.93

## Testing and Results

### FEA of Base Design

- Base design will withstand the stress of the bands
- Maximum deflection of 2.86 mm

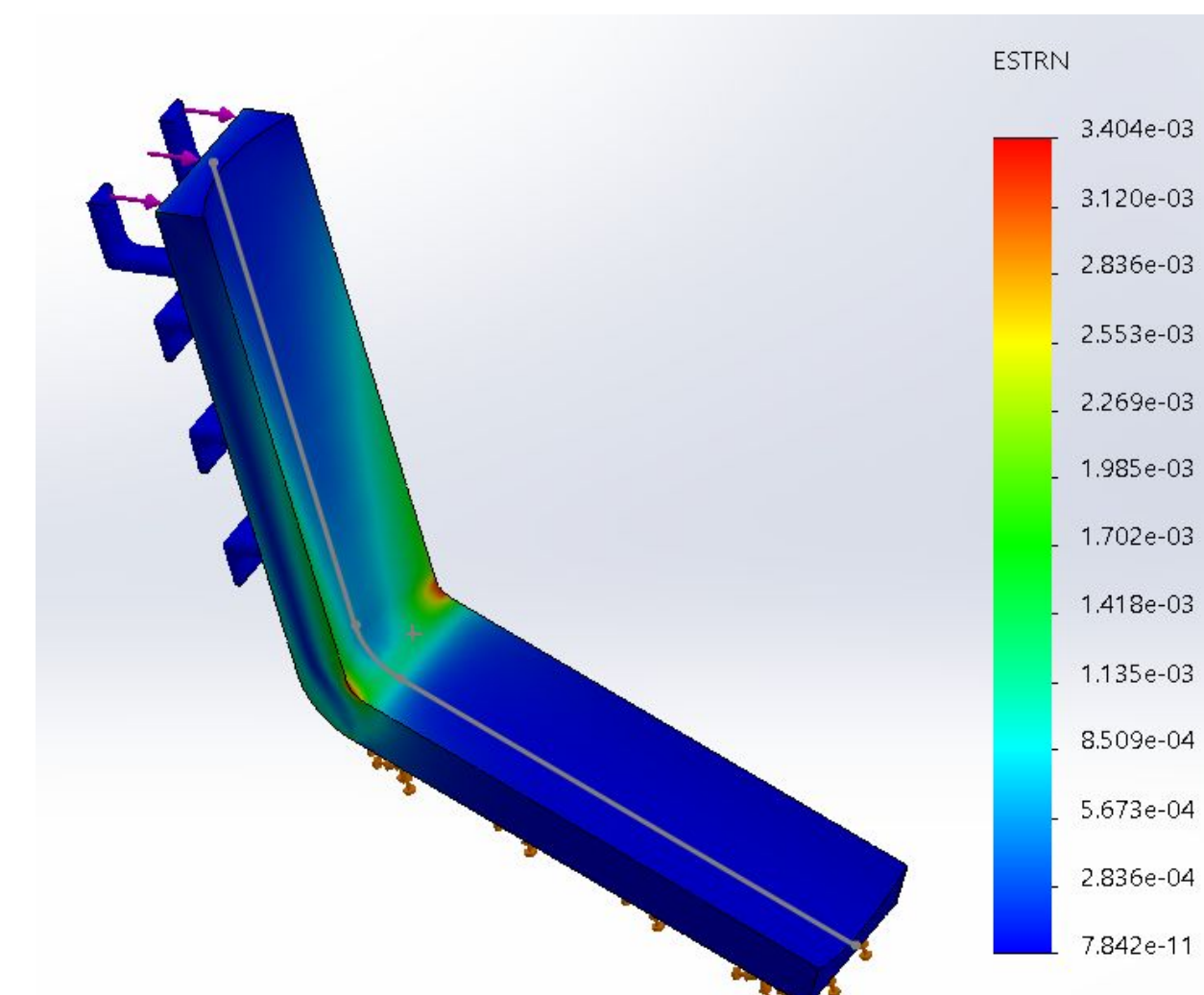

Figure 5: Strain representation of base design under resistance band load

### FEA of Handle Design

- Handle design will withstand the stress of the bands
- Maximum deflection of  $3.57 \times 10^{-4}$  mm.

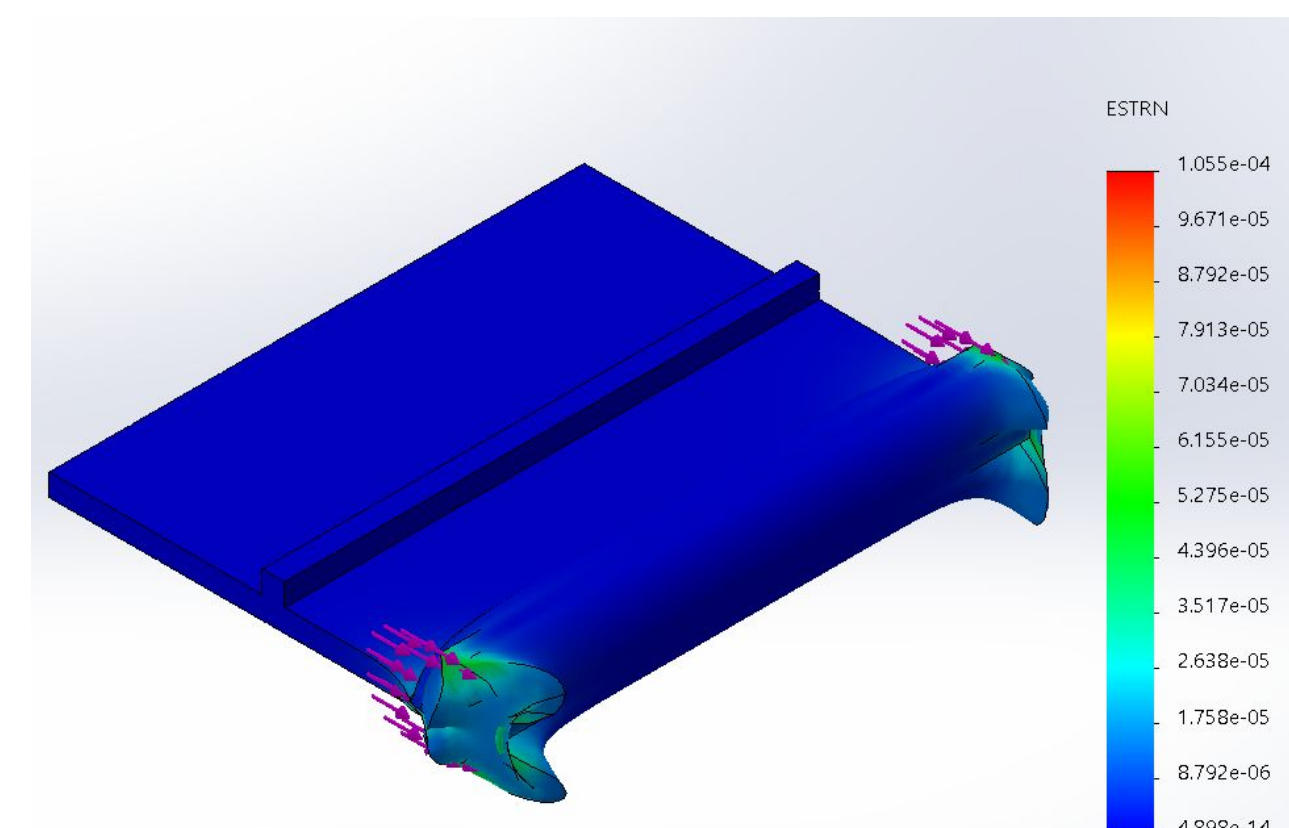

Figure 6: Strain representation of handle design under resistance band load

### Conclusion

- Full design has the ability to withstand the force exerted by the bands.

## Final Design



Figure 7: Original design with updated resistance bands

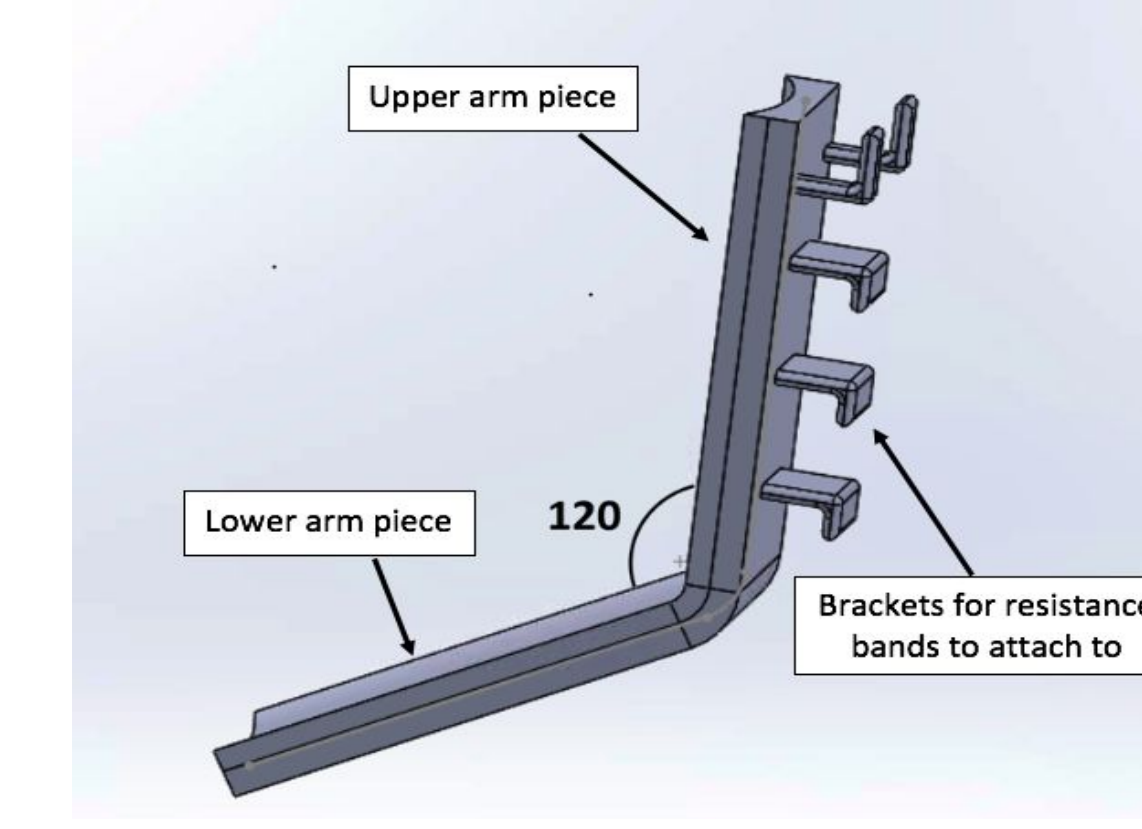

Figure 8: Proposed design of back piece

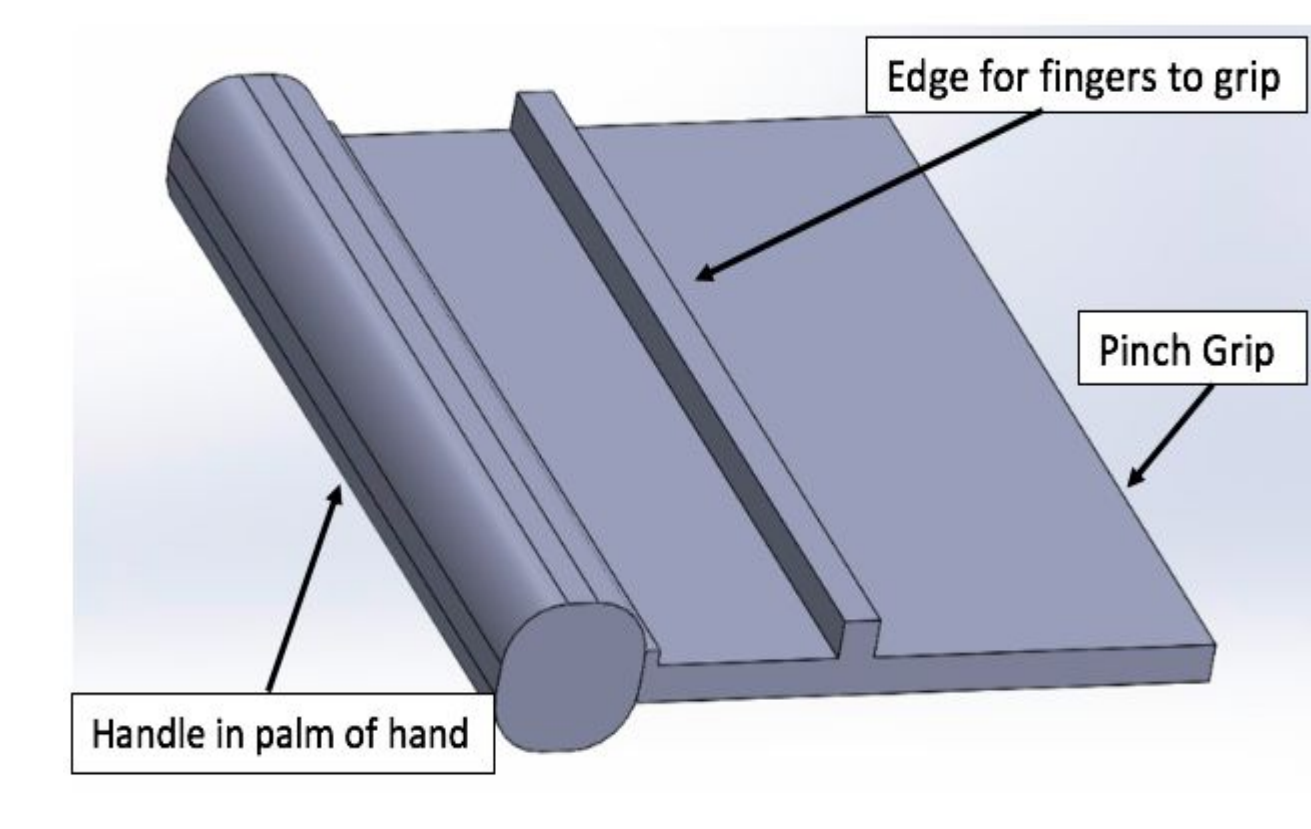

Figure 9: Proposed handle design for grip strengthening

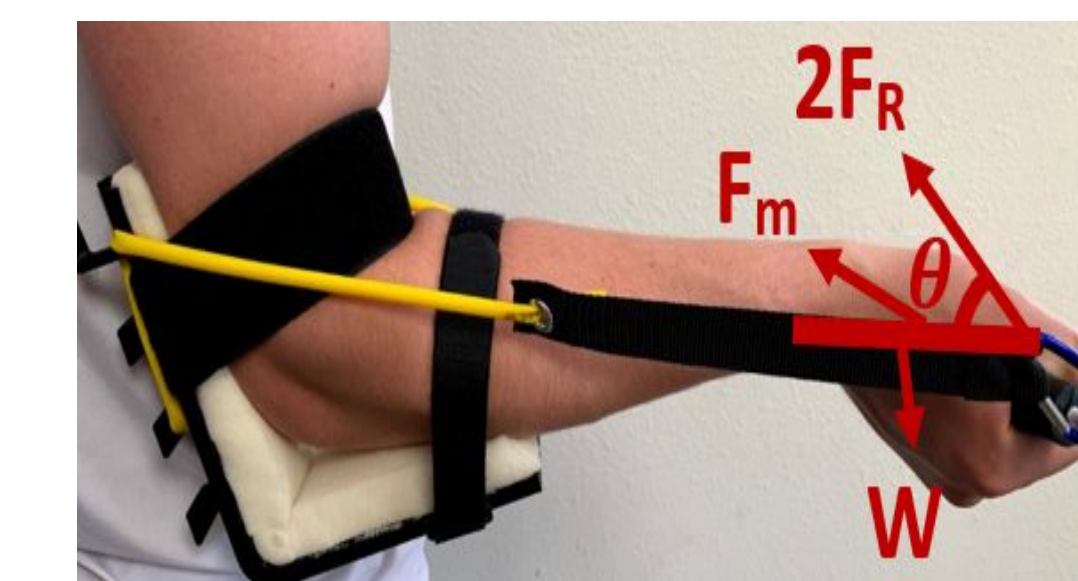

Figure 10: FBD for the extensors and flexors

$$F_m = \frac{L \cdot 2F_R \sin \theta - W \cdot d_w}{MA}$$

$$F_m = \frac{2F_R \sin \theta}{MA}$$

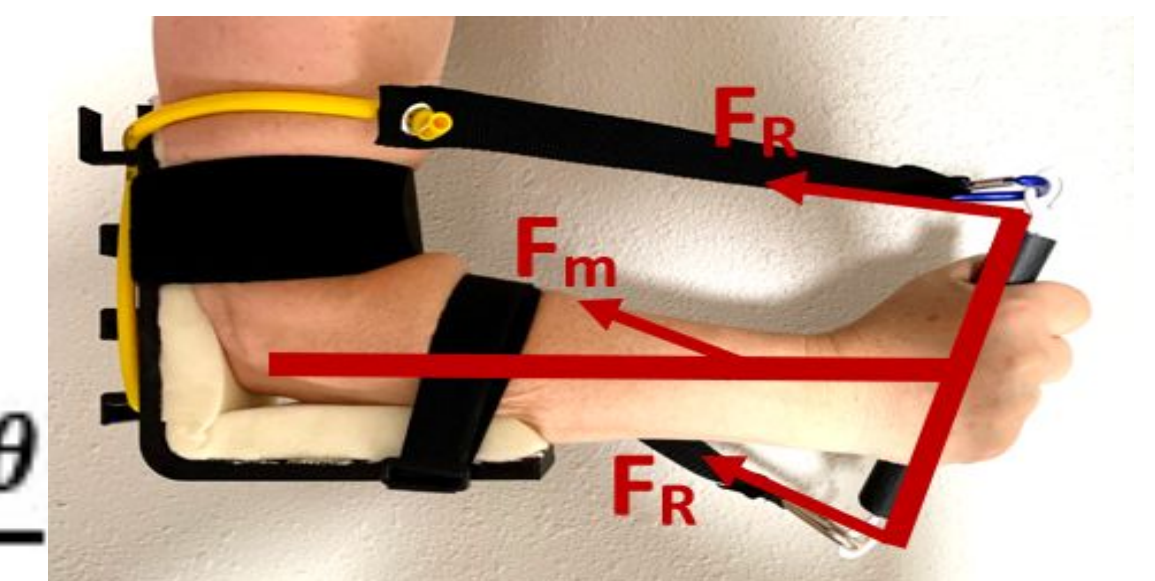

Figure 11: FBD for the pronator teres



Figure 12: Forearm motions used with the device. Shown is the original design with updated resistance bands.

## Future Work

- Tightening mechanism for straps
  - A tension lock similar to those on backpack
- Injection Molding
  - Considered as a mode of fabrication for final prototype after CAD designs are finalized
  - Protolabs Manufacturing
- Removable pinch grip feature
- Testing
  - EMG to confirm isolation of forearm muscles from bicep
  - MTS testing of resistance tubes
  - Usability survey

## Acknowledgements

We would like to thank the following for making this project possible:

- Dr. Chris Vandivort
- Dr. John Puccinelli
- Dr. Christa Wille
- UW-Madison BME Faculty and Staff

## References

- E. Davis, PhD, private communication, Sept. 2019.
- Andros, I. (2019). How to Prevent and Treat Rock Climber's Elbow. [online] Mojo Gear. Available at: <https://mojogear.com/journal/2014/04/01/got-elbows-a-guide-to-coping-with-climbers-elbow/> [Accessed 7 Sep. 2019].
- Edwards, A. and Evans, K. (2019). Stretches to Avoid Elbow Pain from Climbing - Gripped Magazine. [online] Gripped Magazine.
- TeachMe Series, Left Forearm. 2020.
- Vive Health. 2020.
- Handmaster Plus, Handmaster Plus. 2020 a.
- Vive Health, Finger Exerciser. 2020.
- DNQDJ. (2019). Height Percentile Calculator by Gender (United States). [online]. Available at: <https://www.dnqdj.com/height-percentile-calculator-for-men-and-women/> [Accessed 8 Oct. 2019].
- ASTM F2276 - 10(2015). ASTM International - Standards Worldwide. 2015. [Online]. Available: <https://www.astm.org/Standards/F2276.htm> [Accessed: 18-Sep-2019].



# CLIMBER'S FOREARM TRAINER

## Future Work

- Tightening mechanism for straps
  - A tension lock similar to those on backpack
- Injection Molding
  - Considered as a mode of fabrication for final prototype after CAD designs are finalized
  - Protolabs Manufacturing
- Removable pinch grip feature
- Testing
  - EMG to confirm isolation of forearm muscles from bicep
  - MTS testing of resistance tubes
  - Usability survey



# CLIMBER'S FOREARM TRAINER



Team Members: Brittany Glaeser, Kaitlin Lacy, Marissa Harkness, Zoe Schmanski, Jonathon Murphy  
 Client: Dr. Chris Vandivort  
 Advisor: Dr. John Puccinelli



College of Engineering  
 UNIVERSITY OF WISCONSIN-MADISON

College of Engineering  
 UNIVERSITY OF WISCONSIN-MADISON

## Abstract

"Climber's Elbow" is a condition experienced by many climbers where the tendon between the forearm flexors and medial epicondyle of the elbow develops microtears. The Forearm Trainer was designed to aid in prevention and rehabilitation of Climber's Elbow. The device includes variable resistances and a grip strengthener handle. The portable device strengthens the flexors and extensors as well as pronators and supinators of the forearm.

## Motivation

Climber's Elbow, also known as Medial Epicondylitis, affects many rock climbers and can be treated through resistance training of the forearm flexors and extensors. A portable device can help aid in the prevention and rehabilitation of this condition.

## Background

- 4 major forearm muscles [1]
- Pronator teres is the muscle of focus
- Movements:
  - Pronation of hand
  - Flexing of the elbow
- Medial Epicondylitis / "Climber's Elbow"
  - Micro-tearing of the pronator teres [2]
  - overuse of the tendon without sufficient recovery
  - Imbalance in strength of flexor muscles versus the extensor muscles = excessive strain [3]

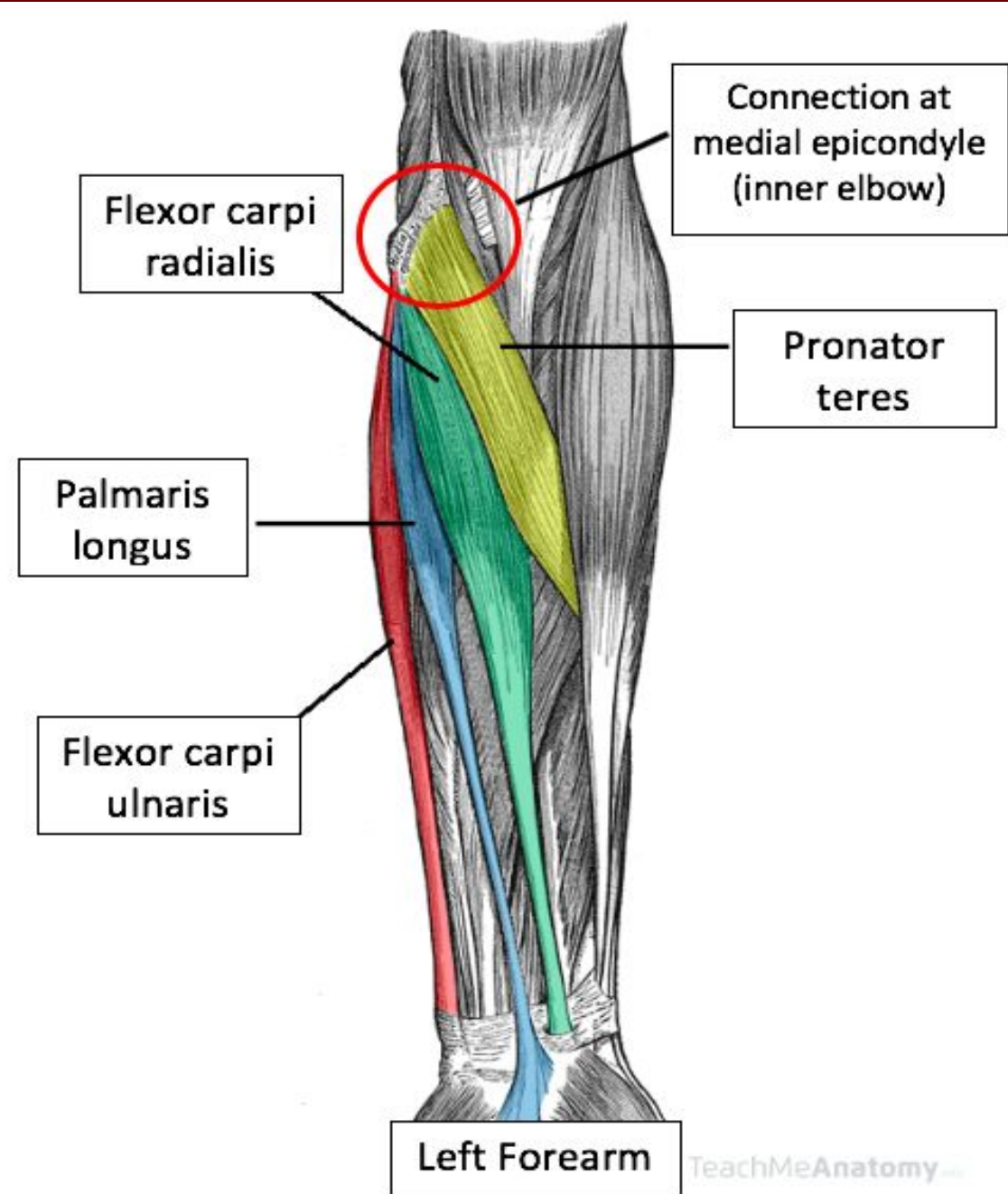

Figure 1: The 4 main muscle groups attached at the medial epicondyle [4]

### Current Devices



Figure 2: Hangboard [5]

Figure 3: Vive Health Finger Exerciser [7]

Figure 4: Handmaster Plus [6]

## Design Criteria

- Effectively targets forearm muscles
- Variable resistances of 5-30 lbs
  - Average forearm length of 23.1 - 26.4 cm
  - Average upper arm length of 29.2 - 33.4 cm [8]
- Durable to withstand daily use for many years
  - Five to ten years for plastic pieces and straps
- Includes grip strengthening component
- Follows ASTM Standards of Fitness [9]
- Easy to use, safe, comfortable, portable and low cost

## Materials

- 3D print - PLA
- Rollerblade straps
- Sponge foam padding
- Flex seal
- Resistance bands
- Carabiners
- 1" Nylon straps
- Hook eye screws
- 0.25" Eyelets
- Brass knurled inserts

Total Costs: \$120.93

## Testing and Results

### FEA of Base Design

- Base design will withstand the stress of the bands
- Maximum deflection of 2.86 mm

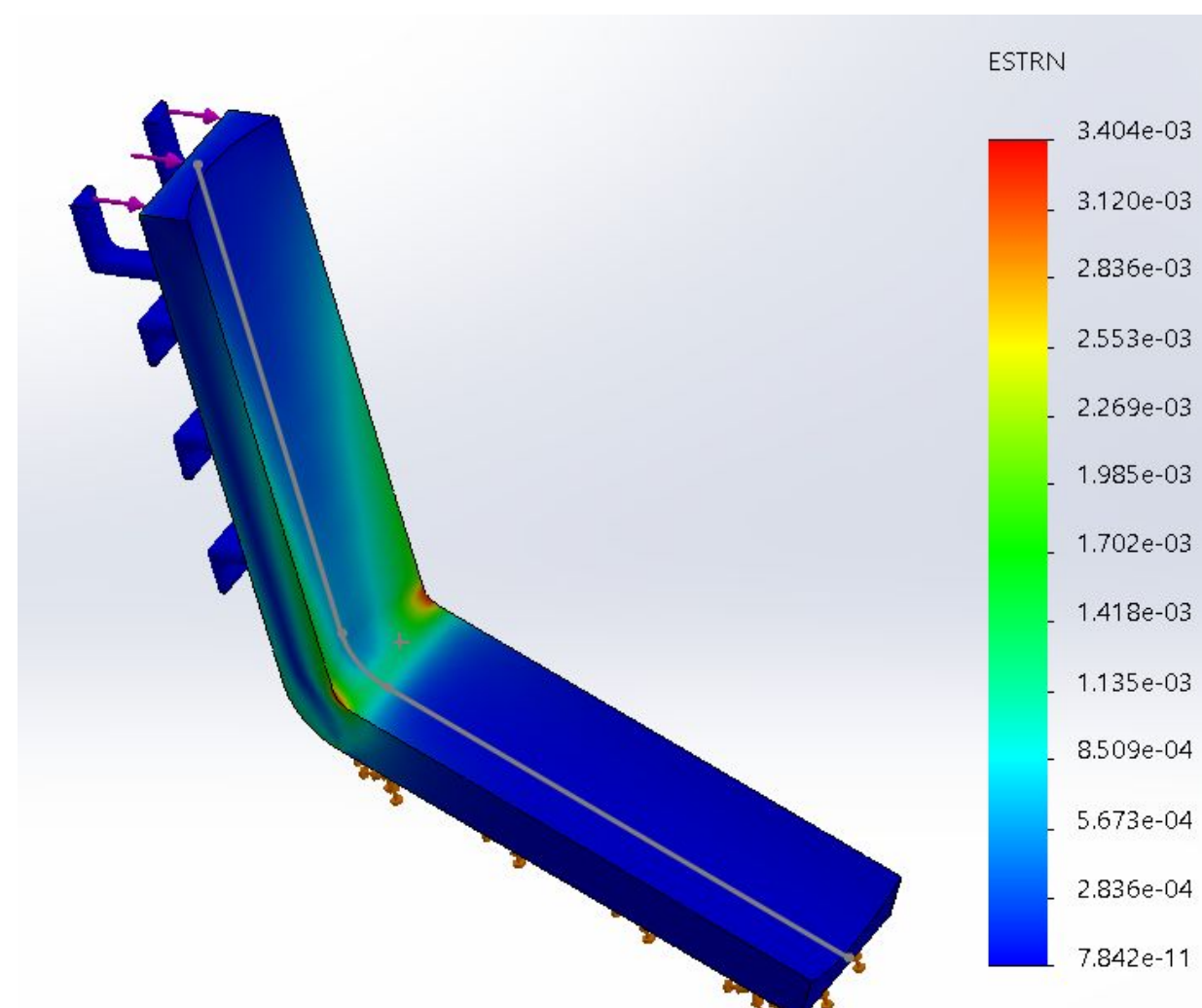

Figure 5: Strain representation of base design under resistance band load

### FEA of Handle Design

- Handle design will withstand the stress of the bands
- Maximum deflection of  $3.57 \times 10^{-4}$  mm.

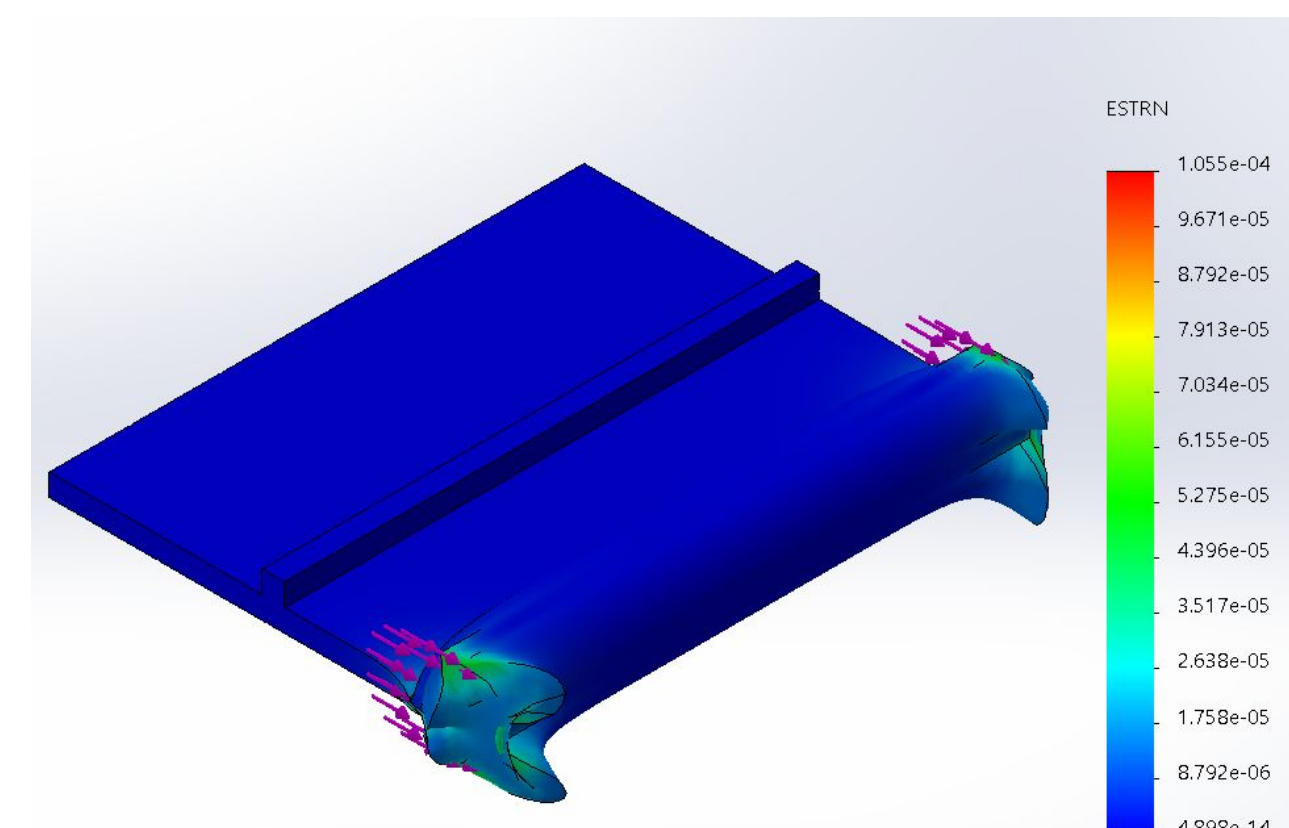

Figure 6: Strain representation of handle design under resistance band load

### Conclusion

- Full design has the ability to withstand the force exerted by the bands.

## Final Design



Figure 7: Original design with updated resistance bands

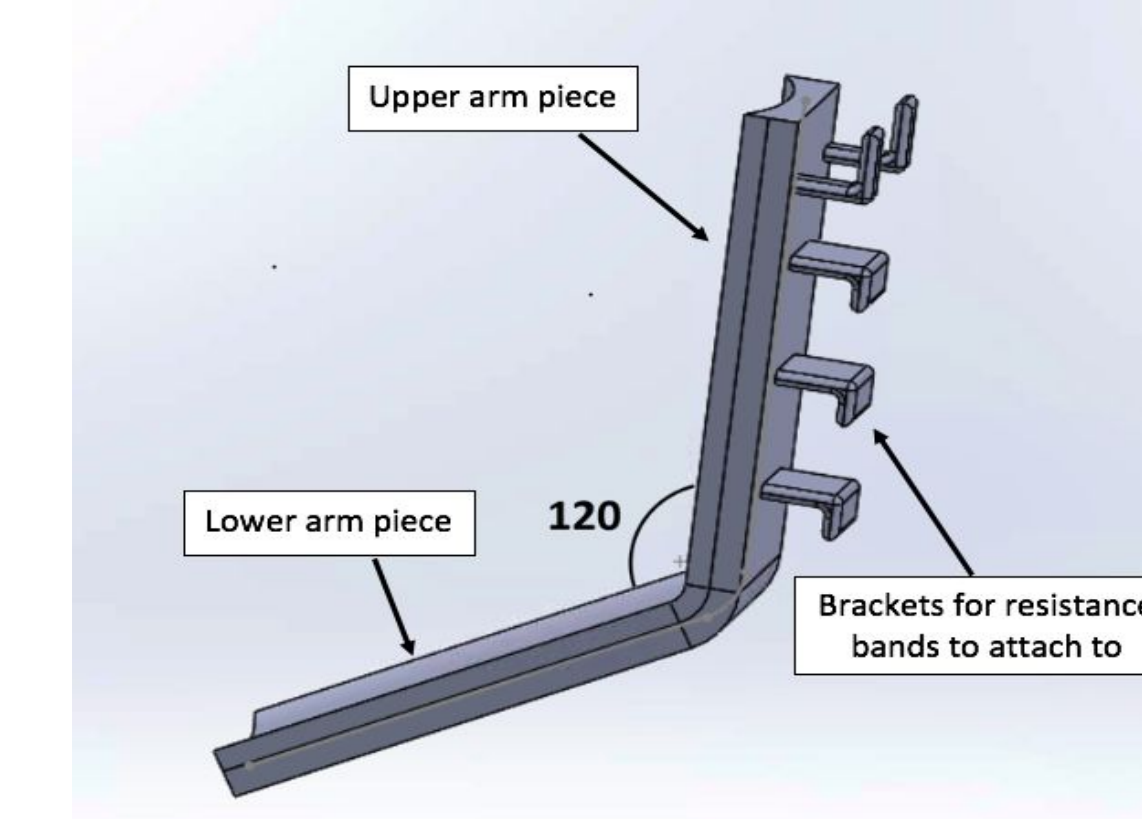

Figure 8: Proposed design of back piece

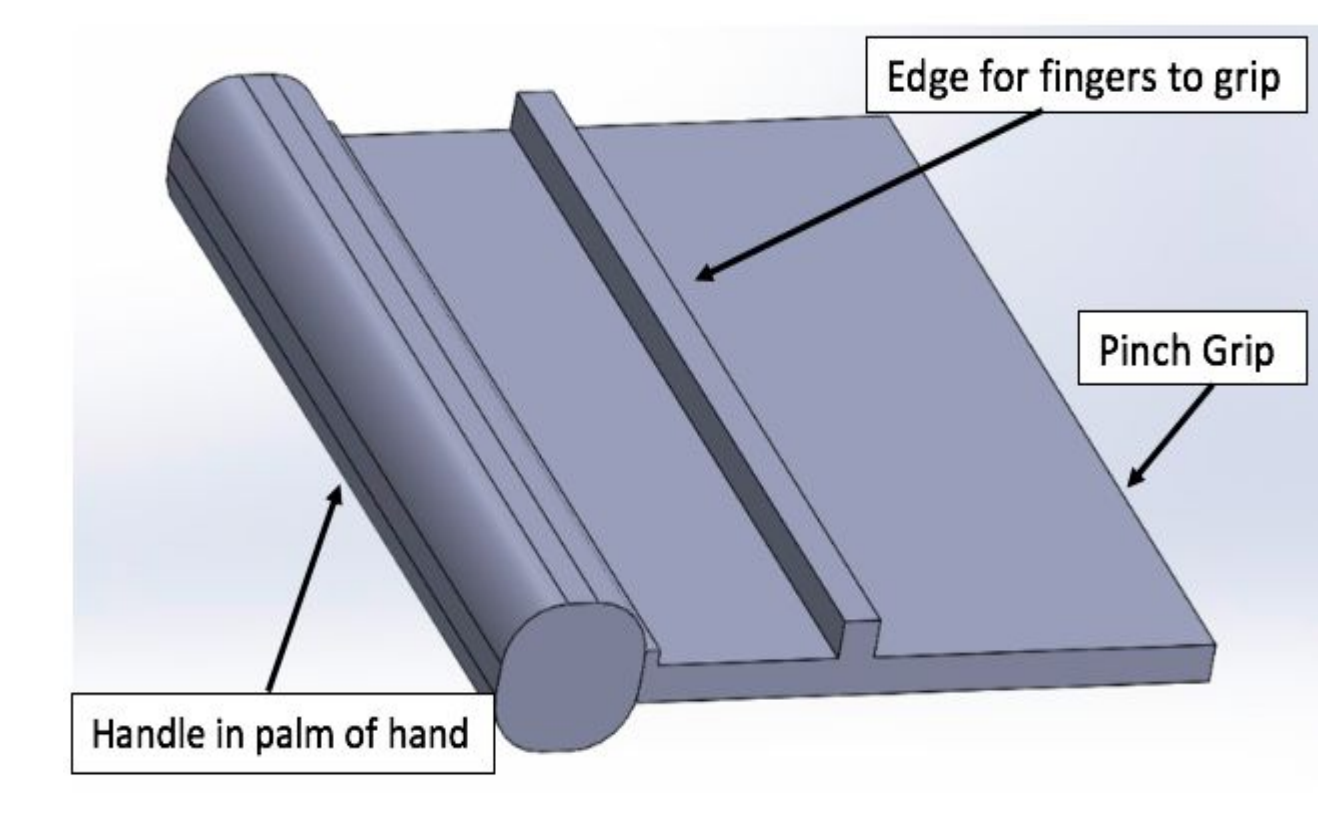

Figure 9: Proposed handle design for grip strengthening

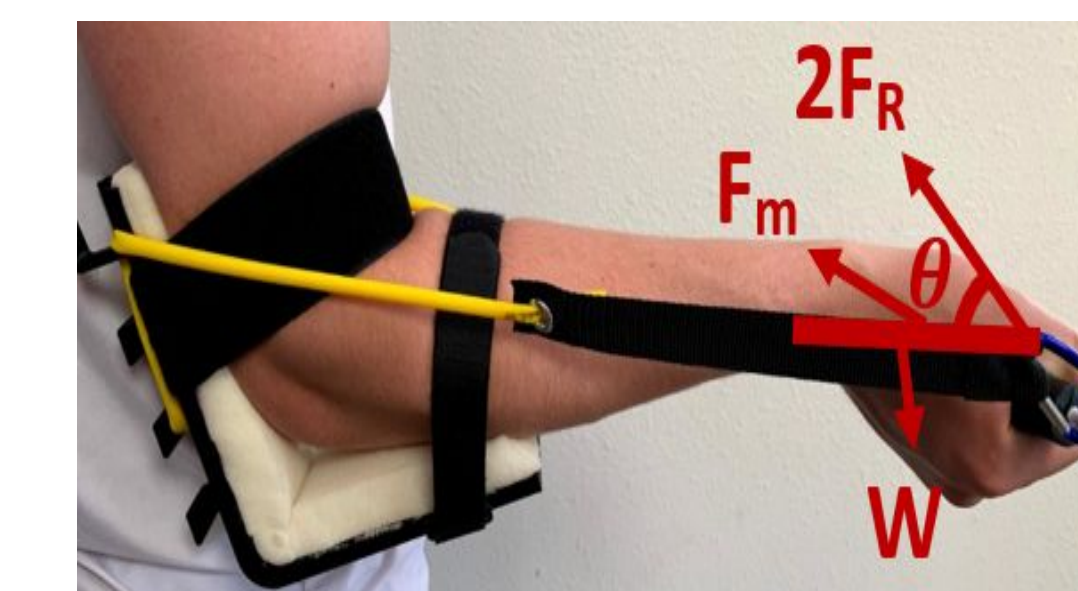

Figure 10: FBD for the extensors and flexors

$$F_m = \frac{L \cdot 2F_R \sin \theta - W \cdot d_w}{MA}$$

$$F_m = \frac{2F_R \sin \theta}{MA}$$

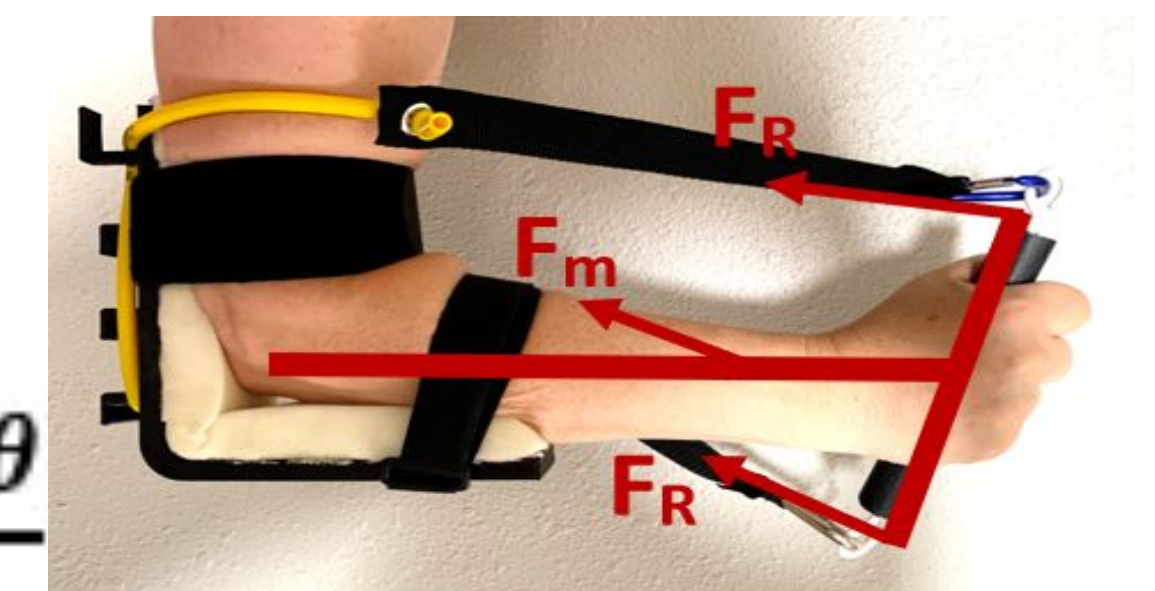

Figure 11: FBD for the pronator teres



Figure 12: Forearm motions used with the device. Shown is the original design with updated resistance bands.

## Future Work

- Tightening mechanism for straps
  - A tension lock similar to those on backpack
- Injection Molding
  - Considered as a mode of fabrication for final prototype after CAD designs are finalized
  - Protolabs Manufacturing
- Removable pinch grip feature
- Testing
  - EMG to confirm isolation of forearm muscles from bicep
  - MTS testing of resistance tubes
  - Usability survey

## Acknowledgements

We would like to thank the following for making this project possible:

- Dr. Chris Vandivort
- Dr. John Puccinelli
- Dr. Christa Wille
- UW-Madison BME Faculty and Staff

## References

- E. Davis, PhD, private communication, Sept. 2019.
- Andros, I. (2019). How to Prevent and Treat Rock Climber's Elbow. [online] Mojo Gear. Available at: <https://mojogear.com/journal/2014/04/01/got-elbows-a-guide-to-coping-with-climbers-elbow/> [Accessed 7 Sep. 2019].
- Edwards, A. and Evans, K. (2019). Stretches to Avoid Elbow Pain from Climbing - Gripped Magazine. [online] Gripped Magazine.
- TeachMe Series, Left Forearm. 2020.
- Vive Health. 2020.
- Handmaster Plus, Handmaster Plus. 2020 a.
- Vive Health, Finger Exerciser. 2020.
- DNQDJ. (2019). Height Percentile Calculator by Gender (United States). [online]. Available at: <https://www.dnqdj.com/height-percentile-calculator-for-men-and-women/> [Accessed 8 Oct. 2019].
- ASTM F2276 - 10(2015). ASTM International - Standards Worldwide. 2015. [Online]. Available: <https://www.astm.org/Standards/F2276.htm> [Accessed: 18-Sep-2019].

# CLIMBER'S FOREARM TRAINER

## Acknowledgements

We would like to thank the following for making this project possible:

- Dr. Chris Vandivort
- Dr. John Puccinelli
- Dr. Christa Wille
- UW-Madison BME Faculty and Staff



# CLIMBER'S FOREARM TRAINER



Team Members: Brittany Glaeser, Kaitlin Lacy, Marissa Harkness, Zoe Schmanski, Jonathon Murphy  
 Client: Dr. Chris Vandivort  
 Advisor: Dr. John Puccinelli



College of Engineering  
 UNIVERSITY OF WISCONSIN-MADISON

College of Engineering  
 UNIVERSITY OF WISCONSIN-MADISON

## Abstract

“Climber’s Elbow” is a condition experienced by many climbers where the tendon between the forearm flexors and medial epicondyle of the elbow develops microtears. The Forearm Trainer was designed to aid in prevention and rehabilitation of Climber’s Elbow. The device includes variable resistances and a grip strengthener handle. The portable device strengthens the flexors and extensors as well as pronators and supinators of the forearm.

## Motivation

Climber’s Elbow, also known as Medial Epicondylitis, affects many rock climbers and can be treated through resistance training of the forearm flexors and extensors. A portable device can help aid in the prevention and rehabilitation of this condition.

## Background

- 4 major forearm muscles [1]
- Pronator teres is the muscle of focus
- Movements:
  - Pronation of hand
  - Flexing of the elbow
- Medial Epicondylitis / “Climber’s Elbow”
  - Micro-tearing of the pronator teres [2]
  - overuse of the tendon without sufficient recovery
  - Imbalance in strength of flexor muscles versus the extensor muscles = excessive strain [3]

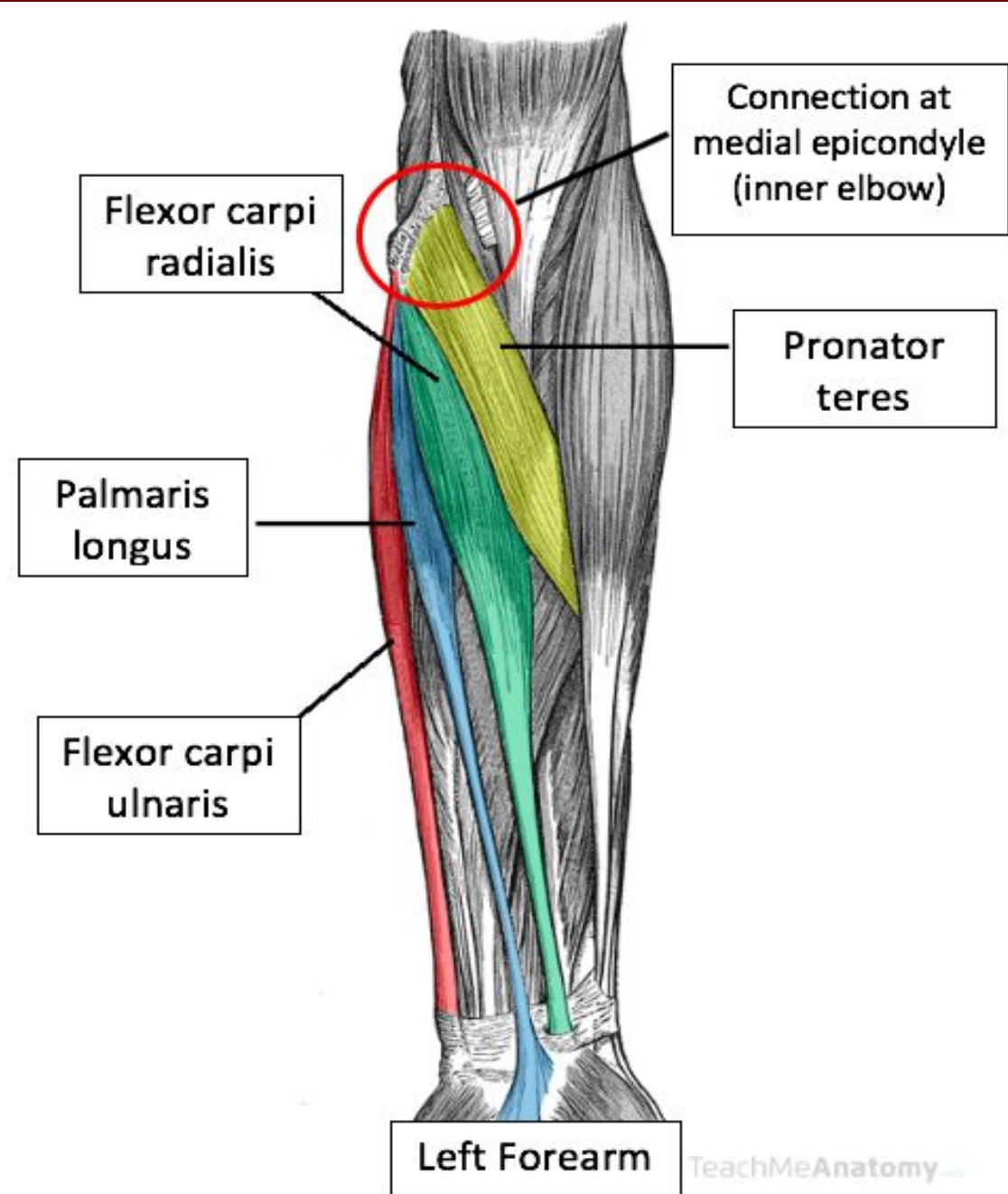

Figure 1: The 4 main muscle groups attached at the medial epicondyle [4]

### Current Devices



Figure 2: Hangboard [5]

Figure 3: Vive Health Finger Exerciser [7]

Figure 4: Handmaster Plus [6]

## Design Criteria

- Effectively targets forearm muscles
- Variable resistances of 5-30 lbs
  - Average forearm length of 23.1 - 26.4 cm
  - Average upper arm length of 29.2 - 33.4 cm [8]
- Durable to withstand daily use for many years
  - Five to ten years for plastic pieces and straps
- Includes grip strengthening component
- Follows ASTM Standards of Fitness [9]
- Easy to use, safe, comfortable, portable and low cost

## Materials

- 3D print - PLA
- Rollerblade straps
- Sponge foam padding
- Flex seal
- Resistance bands
- Carabiners
- 1” Nylon straps
- Hook eye screws
- 0.25” Eyelets
- Brass knurled inserts

Total Costs: \$120.93

## Testing and Results

### FEA of Base Design

- Base design will withstand the stress of the bands
- Maximum deflection of 2.86 mm

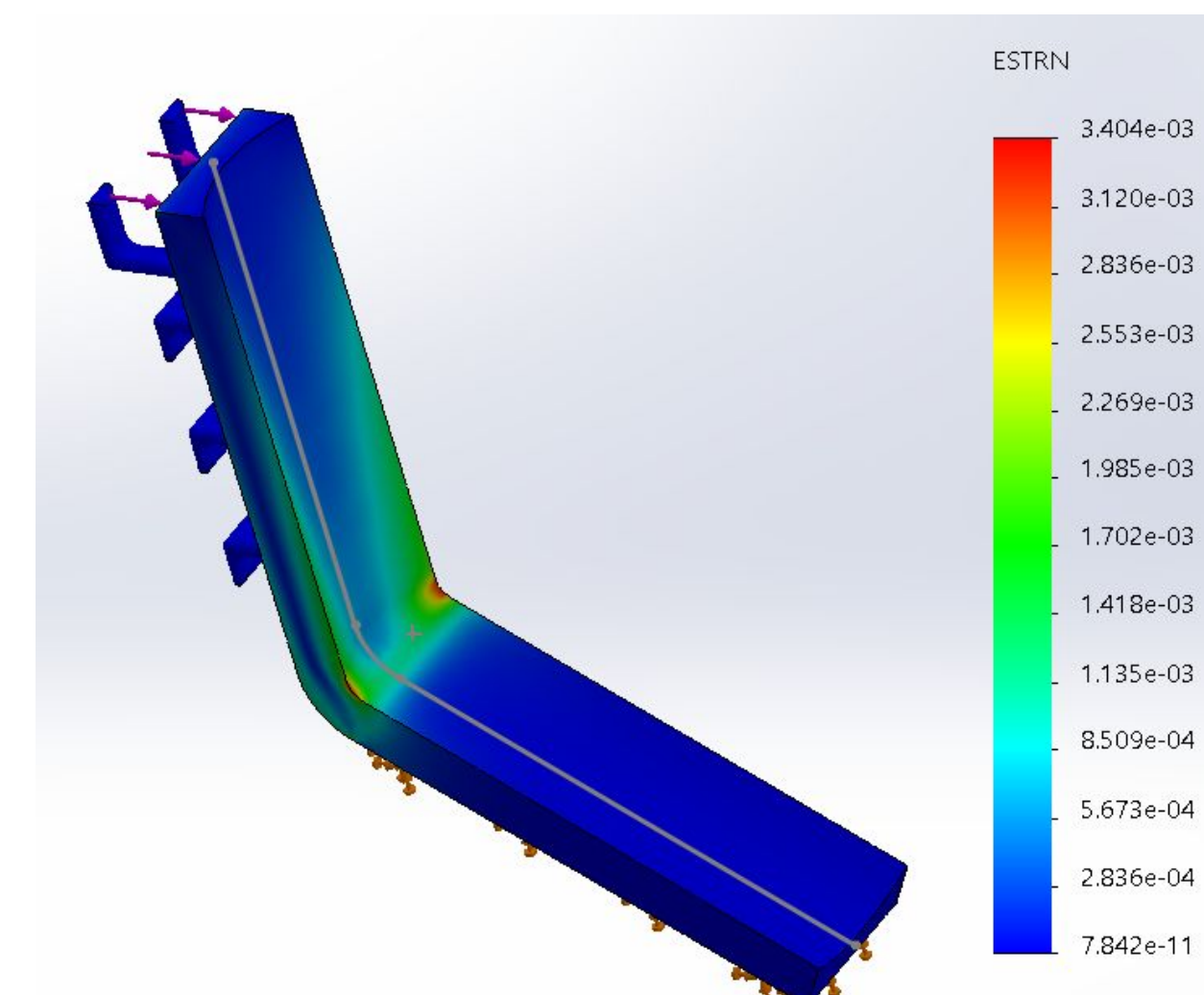

Figure 5: Strain representation of base design under resistance band load

### FEA of Handle Design

- Handle design will withstand the stress of the bands
- Maximum deflection of  $3.57 \times 10^{-4}$  mm.

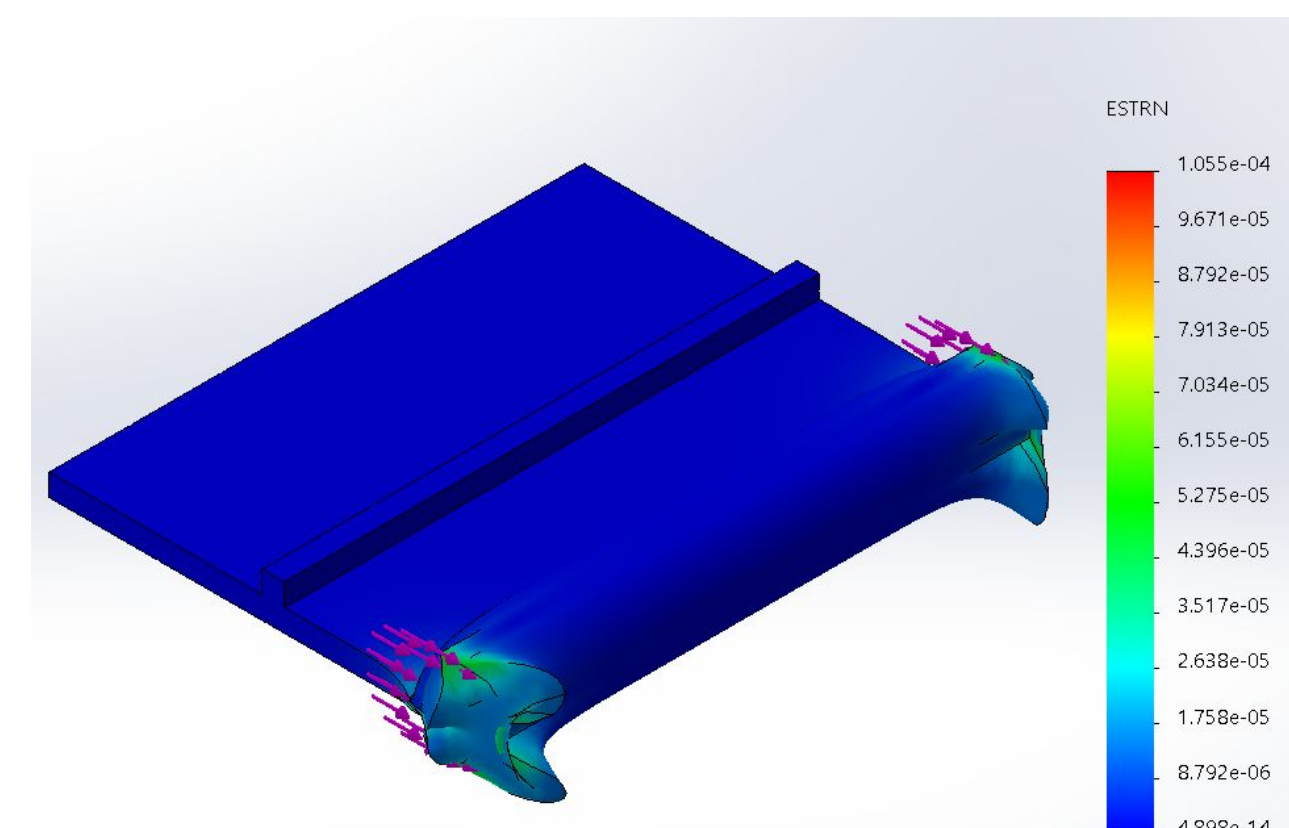

Figure 6: Strain representation of handle design under resistance band load

### Conclusion

- Full design has the ability to withstand the force exerted by the bands.

## Final Design



Figure 7: Original design with updated resistance bands

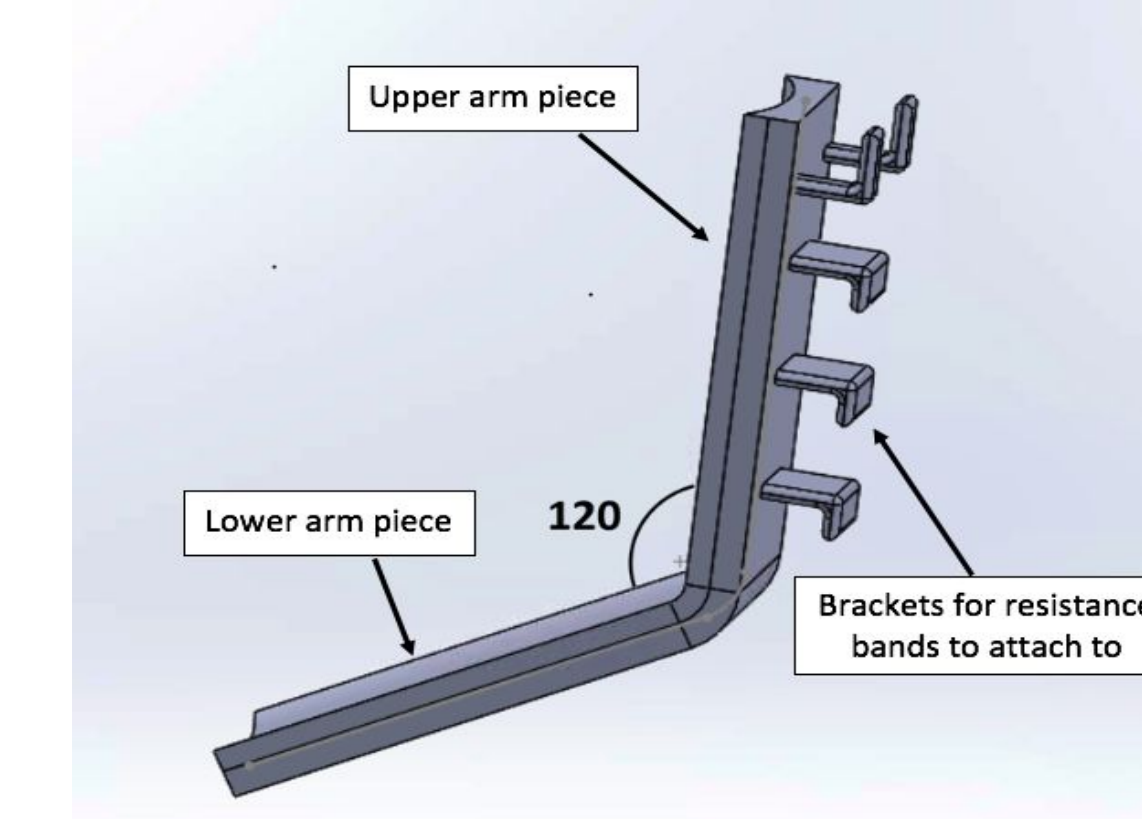

Figure 8: Proposed design of back piece

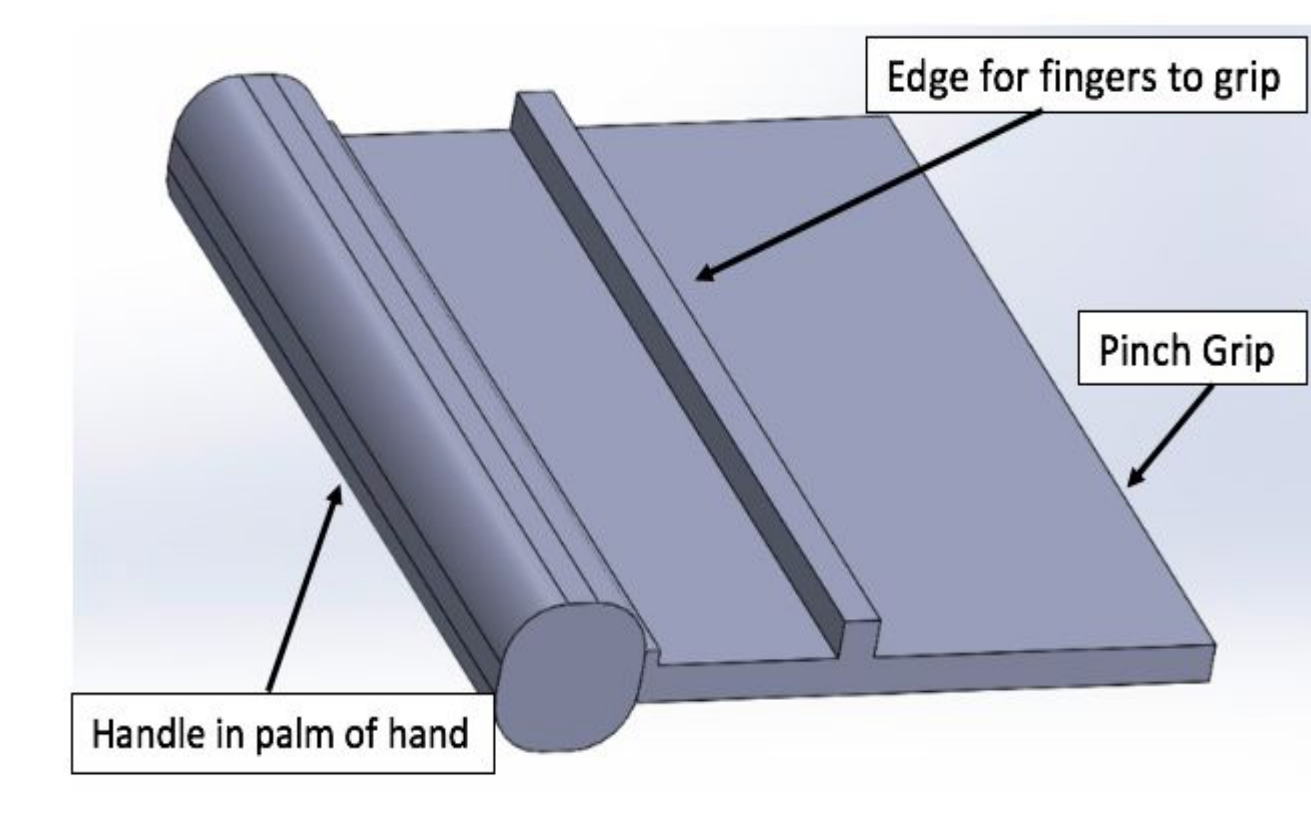

Figure 9: Proposed handle design for grip strengthening

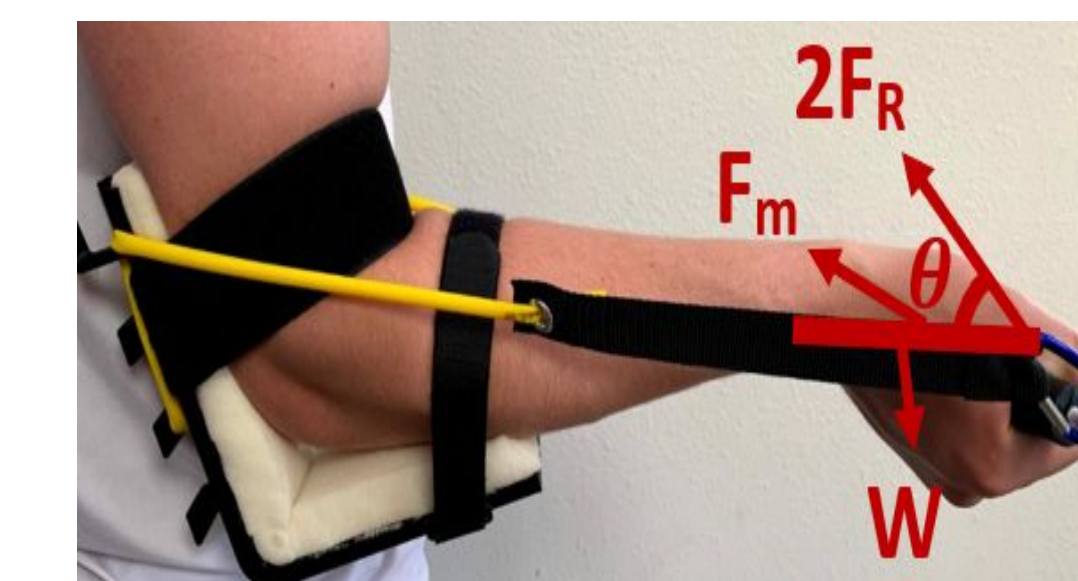

Figure 10: FBD for the extensors and flexors

$$F_m = \frac{L \cdot 2F_R \sin \theta - W \cdot d_w}{MA}$$

$$F_m = \frac{2F_R \sin \theta}{MA}$$

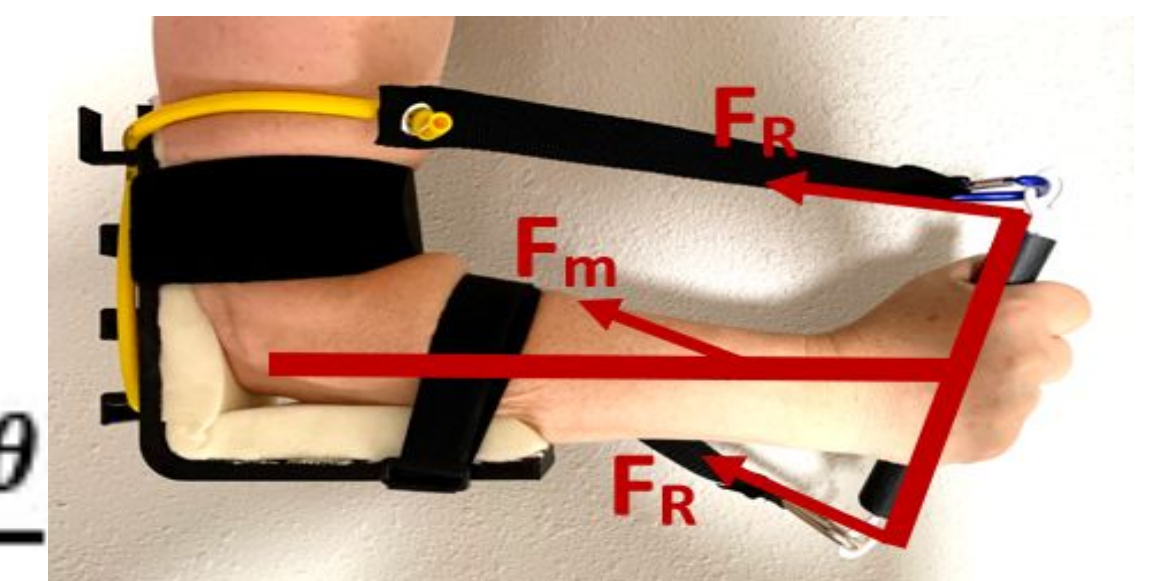

Figure 11: FBD for the pronator teres



Figure 12: Forearm motions used with the device. Shown is the original design with updated resistance bands.

## Future Work

- Tightening mechanism for straps
  - A tension lock similar to those on backpack
- Injection Molding
  - Considered as a mode of fabrication for final prototype after CAD designs are finalized
  - Protolabs Manufacturing
- Removable pinch grip feature
- Testing
  - EMG to confirm isolation of forearm muscles from bicep
  - MTS testing of resistance tubes
  - Usability survey

## Acknowledgements

We would like to thank the following for making this project possible:

- Dr. Chris Vandivort
- Dr. John Puccinelli
- Dr. Christa Wille
- UW-Madison BME Faculty and Staff

## References

- E. Davis, PhD, private communication, Sept. 2019.
- Andros, I. (2019). How to Prevent and Treat Rock Climber's Elbow. [online] Mojo Gear. Available at: <https://mojogear.com/journal/2014/04/01/got-elbows-a-guide-to-coping-with-climbers-elbow/> [Accessed 7 Sep. 2019].
- Edwards, A. and Evans, K. (2019). Stretches to Avoid Elbow Pain from Climbing - Gripped Magazine. [online] Gripped Magazine.
- TeachMe Series, Left Forearm. 2020.
- Vive Health. 2020.
- Handmaster Plus, Handmaster Plus. 2020 a.
- Vive Health, Finger Exerciser. 2020.
- DNQDJ. (2019). Height Percentile Calculator by Gender (United States). [online]. Available at: <https://www.dnqdj.com/height-percentile-calculator-for-men-and-women/> [Accessed 8 Oct. 2019].
- ASTM F2276 - 10(2015). ASTM International - Standards Worldwide. 2015. [Online]. Available: <https://www.astm.org/Standards/F2276.htm> [Accessed: 18-Sep-2019].