

Tandem Bicycle for Individual with Autism

Callie Mataczynski, Aaron Wagner, Eric Arndt

29 April 2020

Abstract

Our project was to design a tandem bicycle that would allow our client, a man with autism, to exercise while riding along with one of his assistants. The device consists of an electric tricycle that is attached to another tricycle; both having the same frame. The electric tricycle is to be operated by one of our client's assistants. Our client would be seated in the rear tricycle. The rear tricycle includes a mechanism that is similar to a stationary bicycle, which allows for our client to exercise while on the device without controlling the overall movement of the device. Another component is implemented to help motivate our client to keep exercising while he is exercising through the use of a device that only plays music while he is pedaling. Several testing procedures were performed to ensure that the device requires similar exercise to that of a standard bicycle.

1. Introduction

1.1 Problem Statement

Our client, Noah, is an adult male with autism. As Noah is getting older, his care team is trying to keep him healthy through exercise. His care team requested that a tandem bicycle be created for Noah and his caretaker; specifically, with an electric bicycle (e-bike) for Noah's caretaker. Noah's portion of the bike would include a secondary pedaling mechanism, separate from the e-bike, that would allow him to exercise while enjoying the outdoors. A bluetooth audio feedback system was also desired to motivate Noah to keep pedaling and get adequate exercise. This

device is to be made specifically for Noah, but there is potential for developing a tandem bicycle that may be useful for other individuals with disabilities.

1.2 Background

1.2.1 Autism

Autism is a developmental disorder that is characterized by a variety of symptoms including difficulty with social interaction, communication, and repetitive behaviors [1]. For many individuals with autism, such as our client, motor skills are also impeded [2]. One of the motor skills that is significantly affected is balance [2]. Because of our client's case, it is necessary

to design a tandem electric bicycle that can only be operated by one of our client's assistants.

1.2.2 Design Components

There are three components that make up this device:

- The Frame
- The Resistance Mechanism
- The User Interface

Each component focuses on a different aspect of the tandem bicycle. The frame was designed with the safety and comfort of our client in mind. The frame must be able to support the weight of two adults and be easily maneuverable for the person operating the device. The resistance mechanism was designed to provide exercise to the client via pedaling. However, the pedaling of the client would not contribute to the overall movement of the device. Lastly, the user interface was designed to provide our client with sensory feedback while he pedals to encourage him to sustain exercise for longer periods of time.

1.3 Design Specifications

The design specifications are as follows:

- The device must support the weight of two adults (400-500 lbs).
- An electric powered bicycle that provides enough power to transport two adults (500 W) [3].
- The device must safely secure the client and remove any possible safety hazards such as an exposed chain, which the client may try to grab.

- This device must run properly three to four times per week.
- The bicycle should operate for two to three hours per use.

2. Methods

2.1 Fabrication

The fabrication of the device was divided into the three components previously mentioned, starting with the frame.

2.1.1 Fabrication of the Frame

The frame consists of two Sun E3 recumbent tricycles connected together via a universal attachment.



Figure 1. The proposed design of the frame of the tandem bicycle.

The tricycle in the front is to be operated electronically by one of our client's assistants. Our client will sit in the back seat, where the resistance mechanism and user interface are installed.

2.1.2 Fabrication of the Resistance Mechanism

The resistance mechanism incorporates the mechanism that is commonly used in stationary bicycles. The casing of the stationary bicycle was removed, leaving the magnet and flywheel. The crank arm of a standard bicycle was then removed, which left only the crank remaining.



Figure 2 [4]. A typical bicycle crank, similar to the one used. The red line indicates where the crank arm was cut off.

A bracket was then created by bending a 1.5 in by 60 in aluminum rod approximately 90 degrees. The bracket was attached to the bicycle frame using five $\frac{3}{8}$ in fine-thread bolts.



Figure 3. The final design of the resistance mechanism. The resistance mechanism from the stationary bicycle is connected to the crank of a standard bicycle and attached to the bicycle frame.

2.1.3 Fabrication of the User Interface

The user interface was developed using an Arduino Uno, bluetooth speaker kit, relay module, battery pack, and a magnetic sensor.

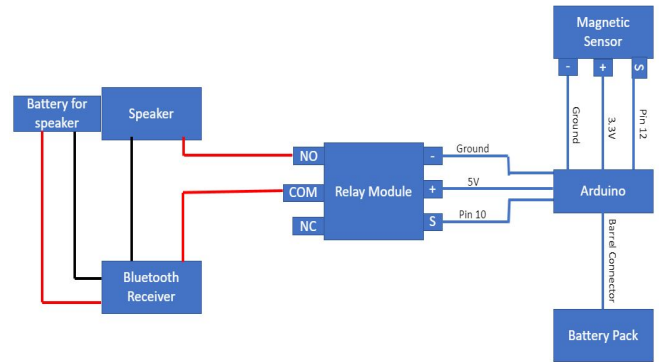

Figure 4. Schematic of the user interface.

The Arduino Uno was connected to a relay module, which also connected to the speaker and bluetooth receiver. Code was written on the Arduino that utilized a magnetic sensor, which was connected to the pedals of the resistance mechanism. The code utilizes the magnetic sensor and a magnet to detect pedaling. While the individual is pedaling, the magnetic sensor will relay to the Arduino that pedaling is occurring. Then, the Arduino will close the circuit to the relay module, allowing for music to play from the speaker. If the magnetic sensor does not sense pedaling for a specified amount of time, such as five seconds, the Arduino will open the circuit running through the relay module. In return, this will stop music from playing from the speaker. The design of the user interface will hopefully provide motivation for our client to exercise because he enjoys listening to music.

2.2 Testing

2.2.1 Testing Wattage Output

The resistance mechanism portion of the device was compared to an actual bicycle in terms of wattage output. This test was performed to ensure that our client would receive exercise on the device that is

similar to the exercise on a normal bicycle. A bicycle computer was used that could measure the distance, speed, and amount of calories burned while pedaling. For each gear combination on the bicycle, 21 total, the calories burned were measured over a pre-set distance. The bicycle computer was then transferred to the resistance mechanism and a similar test was performed for all the possible gear combinations on the device. The wattage outputs between the bicycle and the resistance mechanism were then compared.

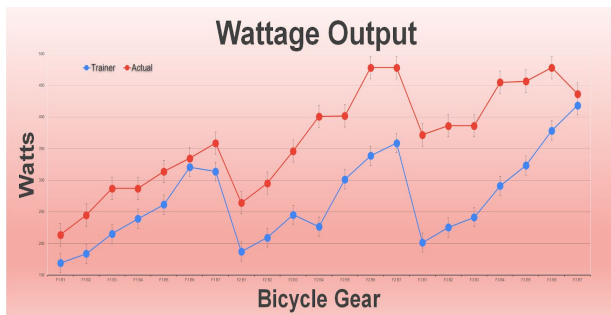

Figure 5. Plot of the wattage outputs vs. bicycle gear. The blue plot represents the data from the resistance mechanism and the red plot represents the data from the bicycle.

As seen in figure 5, the resistance mechanism and the bicycle portray similar trends in terms of wattage output versus bicycle gear. The maximum wattage output of the standard bicycle was 478 W, while the resistance mechanism provided a maximum wattage output of 418 W. Although there is approximately a ten percent difference in maximum wattage outputs, this is not believed to cause a substantial difference in terms of exercise between the two conditions. Also, many of the gears provided similar wattage outputs that were well within ten percent of one another. For example, the wattage outputs

at the final gear combination were within five percent of one another. It can be concluded that the resistance mechanism can be used to allow for sufficient exercise similar to that of riding a standard bicycle.

2.2.2 Comfort Testing

To test the comfort of the device, a comfortability test was developed. This test was done in the form of a survey. A group of individuals were asked to sit on multiple bicycle seats and give a rating of how comfortable the seat was, with ten being the most comfortable. The bicycle seat that was designed for our client received a seven. Although this is more of a qualitative measurement, it can be concluded that the device will provide sufficient comfort for our client and his assistants.

3. Conclusion

3.1 Results

The resulting design is believed to be sufficient for the needs of our client. The successful combination of the frame, resistance mechanism, and user interface allows for an interactive, user friendly device that will help to encourage our client to live an active, healthy lifestyle. We believe that this device achieves the goals that were set in the product design specifications previously listed.

The frame provides a safe and comfortable support for our client and his assistant while riding the bike. The frame of the device is also expected to provide plenty of maneuverability that will allow for a smooth driving experience for the individual operating it. Although an electronic component has not yet been implemented, there are plenty of electric bicycles that

provide more than enough power to transport two individuals.

The resistance mechanism provides a mechanism, similar to a stationary bicycle, that provides a similar exercise experience that would be encountered for a standard bicycle. The resistance mechanism also allows the client to exercise without contributing to the overall movement of the bicycle, which was a necessary specification for this device.

The user interface encourages our client to continue exercising while riding the bicycle through the use of music. Because our client enjoys music, we believe our user interface, which only plays music while he pedals, will motivate him to remain exercising for extended periods of time.

3.2 Future Work

As the semester comes to a close, there are several aspects of the device that still require improvement to reach our client's needs. Several of the improvements come in the form of miscellaneous attachments onto the device. One of these attachments is a canopy that would help enclose our client. We believe this would be beneficial because it provides a more enclosed and safe environment in which he enjoys. This canopy would also protect him from injuring his fingers on the bicycle chain. Other attachments include baskets. Because our client likes to travel with many things, including a water bottle, blanket, and iPad, it is necessary to provide storage for these in the form of bicycle attachable baskets.

We also wish to develop an apparatus that would allow for our client to be secured by a harness that he uses while riding in cars. The harness is similar to a

seatbelt of a car, however, it is much more secure. This harness will allow our client to stay seated and prevent him from intervening with his assistant who is operating the device.

3.3 Acknowledgements

We would like to thank all of the people who helped us with this journey. Our Client, Noah, his assistant, Michael, and his mother, Lu. We would also like to thank our advisors Dr. Beth Meyerand and Dr. Christopher Luzzio.

References

- [1] "What Are the Symptoms of Autism?," *Autism Speaks*. <https://www.autismspeaks.org/what-are-symptoms-autism> (accessed Oct. 7, 2019).
- [2] "Motor problems in autism persist into adulthood," *Spectrum | Autism Research News*, Nov. 11, 2017. <https://www.spectrumnews.org/news/motor-problems-autism-persist-adulthood/> (accessed Apr. 28, 2020).
- [3] "How Much Power Does An Electric Bicycle Need?," *EbikeSchool.com*, Aug. 24, 2014. <http://www.ebikeschool.com/much-power-electric-bicycle-need/> (accessed Apr. 22, 2020).
- [4] "Shimano Dura-Ace FC-9000 11-Speed Crankset (172x39-53) SIL/BK." <https://www.planetpedals.com/itemdetail.asp?mod=21384#.XqhvlGhKhPY> (accessed Apr. 23, 2020).

Appendix

Product Design Specifications

Tandem bike for person with Autism

Team: Callie Matacyznski, Aaron Wagner, Eric Arndt, Mengizem Tizale

Date: September 20th, 2019

Function: (a general statement of what the device is supposed to do): The PDS should begin with a brief, concise paragraph describing (in words) the overall function of the device. In the initial stages, this will be the problem statement, and will become more specific as you decide on a final design.

A family has requested that a tandem bike be constructed so that their adult autistic child can go for rides with an attendant. The bike should provide the autistic individual a physical workout while supplying them with a positive feedback system that encourages them to keep pedaling. The bike should also be fully operated by the attendant to the autistic individual with an electric motor to aid in their pedaling.

Client requirements (itemize what you have learned from the client about his / her needs):

- Support the weight of two adults
- Very stable
- An electric motor as part of the front half of the bike
- No gears exposed on the back half of the bike
- A harness to secure the autistic individual in the back seat of the bike
- Some sort of feedback system to reward the autistic individual when they help pedal the bike
- Resistance to the back pedals to keep the autistic individual physically active
- No steering or brake capabilities for the back seat

Design requirements: This device description should be followed by a list of all relevant constraints, with the following list serving as a guideline. (Note: include only those relevant to your project):

1. Physical and Operational Characteristics

a. Performance requirements:

The product should have the ability to give the autistic individual the full experience of riding a bike, but in a safe manner. The bike also needs to have an electric motor to power the front half of the bike for the attendant to use whenever necessary. The attendant should also have full control of the bike for steering and stopping. The back half of the bike should be intended for the autistic individual. This half needs to include some sort of resistance to the pedals, so they can be physically active while riding. The back half

of the bike should also include a harness as part of the chair to safely secure the autistic individual to the bike. Finally, it would be desirable for the autistic individual to be rewarded when they pedal through some sort of feedback system (ex. light turns on).

b. *Safety:*

The device must be able to support the weight of the autistic individual and the attendant along with them. A rough estimate of the overall weight would be in the ballpark of 400-500lbs. The device also needs a harness for the back seat, to keep the autistic individual from falling off of the bike. Next, the device needs to be very stable, so the bike cannot tip over while driving. Finally, gears cannot be exposed in the back half of the bike near the autistic individual, as they could get their fingers or other body parts caught in it.

c. *Accuracy and Reliability:*

The device should be reliable and have the ability to withstand repetitive use from the users without breaking down. The electric motor on the device should be able to hold a good charge to allow the users to go on rides of longer distances if desired. Finally, the seats on the device should cause no pain or discomfort to the users, while still maintaining a very high level of safety.

d. *Life in Service:*

The device should run properly 3-4 times a week if necessary. The battery should last long enough for a single trip that may take up to a few hours.

e. *Shelf Life:*

The ideal shelf life of this device will be throughout the client's lifetime. The current goal is for the bike to last 20 years if maintained correctly. The electric portion of the bike may have to have to undergo small maintenance earlier.

f. *Operating Environment:*

The device is mainly going to be exposed to a normal outdoor environment in the spring, summer, and fall months in Wisconsin. It is expected that the bicycle will only be used on days of nice weather, however it should be able to withstand some rain and wind if poorer conditions intervene a sunny day. While stored in the winter months, the bicycle may be exposed to very cold temperatures, which it must withstand as well. The bicycle should be able to withstand the weight of two fully grown adults (up to 500lbs).

g. *Ergonomics:*

The device is to be operated electrically, which will remove most worries about the force required for an individual to have to bike two fully grown adults around. However, this device still needs to act in a safe, efficient manner while transporting the two people. The device should be easy to control via some type of steering mechanism. The front of the bike, where the operator is must be further than an arm's

reach away from the back of the device where the client will be to avoid potential physical altercations between the two.

h. *Size:*

There is no exact maximum length of the device at this moment, only the fact that it must be able to fit inside a garage to be stored. The minimum length must fulfill the need assessed above; that the client will not be able to reach the person operating the bicycle. The device must also must be large enough to comfortably seat the client, who is approximately 6'0 and 230lbs.

i. *Weight:*

There are currently no established restrictions on the weight of the tandem bike. However, Noah is about 230lbs and the staff biker is also an adult and these weights, along with the other components of the bike, must be considered in the design.

j. *Materials:*

Currently there are no restrictions on the kinds of materials we can consider for potential design solutions.

k. *Aesthetics, Appearance, and Finish:*

The aesthetics of the tandem bike design should heavily consider safety. All potentially injurious components (i.e. chains, edges, or corners) should be elegantly concealed or padded.

2. Production Characteristics

a. Quantity:

This is a custom design project for a single client. Only one unit is needed.

b. Target Product Cost:

The team has not yet established a target cost, we are currently in the process of researching and conceptualizing design ideas. Although it is too early to say, manufacturing costs should not be high as the team will utilize the TEAM LAB to manufacture the design. A brief competing designs research suggests that tandem recumbent bikes are approximately \$3000.

3. Miscellaneous

a. Standards and Specifications:

There is no FDA approval required for this product, however an IRB should be checked in order to have a person using the device. Furthermore, HIPPA standards should require the team and the client to be confidential unless otherwise specified by the client.

Normal bike standards should be established such as mirrors, helmets, and turn signals. Either in the form of lights or hand gestures. This is stated by the State of Wisconsin's Department of Transportation specifically in The Wisconsin State Legislature Bicycle[340.01(5)].

b. Customer:

The client enjoys music and being active. The client also can not handle loud noises and sudden distractions. Also, comfortability to the belt being used is important

c. Patient-related concerns:

- Concerns related to autism should be taken into account. This includes interaction with the device and the user. Furthermore, storage of this bike needs to be able to fit in a car.

d. Competition:

Many tandem bikes exist such as TerraTrike and tandem e-bikes such as RunAbout bikes. Trailers

from Thule also exist for children and adults. However, none of these designs have been custom fit to our clients needs, so no current technology exists for our user.

Expenses

Date	Item	Cost	Comments
11/4/2019	Stamina Folding Upper & Lower Body Cycle with Monitor	\$22.52	Students purchased this from Walmart. Reimbursement completed
11/4/2019	Bike Trainer	\$35.00	Students purchased this from Facebook Marketplace.
11/19/2019	Sun E3 Recumbent Trike	\$500.00	Bike purchased with Department Card from: Dream Bikes Address: 4245 W Beltline Hwy, Madison, WI 53711
2/11/2020	Rockler Wireless Speaker Kit	\$38.98	Purchased online off the Rockler Website. Reimbursement processing
2/11/2020	OSEPP Reed Switch Module	\$12.31	Purchased off Amazon. Reimbursement processing
2/28/2020	Stamina Cardio Folding Exercise Bike	\$89.00	Purchased from the Madison Walmart with the BME department card.
3/5/2020	Tolako 5V Relay Module	\$5.50	Purchased off Amazon. Reimbursement processing
3/5/2020	4xAA Battery Holder	\$6.49	Purchased off Amazon. Reimbursement processing
3/5/2020	Pack of 8 AA Batteries	\$4.56	Purchased off Amazon. Reimbursement processing
3/20/2020	Hex Coupling Nut	\$10.99	Purchased off Amazon. Reimbursement processing
4/21/2020	Hase Universal Coupler	\$129.00	Purchased at the Hostel Shoppe bike shop. Reimbursement processing.
		Total: \$854.35	