

Research Article
An Improved Method of Securing Surgical Drains

Abdoulahi Bah^a, Dana Stumpfoll^a, Lauren Heller^a, Oscar Zarneke^a, Rebekah Makonnen^a

^aDepartment of Biomedical Engineering, University of Wisconsin - Madison, WI, USA

Short Title: Drain Pain

Journal: Breast Care

Corresponding Author:

Dr. Tracy Jane Puccinelli

Department of Biomedical Engineering

University of Wisconsin - Madison

1415 Engineering Drive

Madison, WI, 53706, USA

E-mail: tracy.puccinelli@wisc.edu

Keywords: surgery, bandage, pain, drain, clip

Abstract

Background: Mastectomies are commonly performed surgeries to treat breast cancer. Following these procedures, surgical drains are commonly placed and secured with sutures, causing discomfort to the patient. **Methods:** Our team has designed a novel technique for securing a surgical drain that reduces tension at the suture site, thus increasing patient comfort. The drain exit site is surrounded by a hydrocolloid bandage, and the drain is secured to a 3D-printed clip that is attached to the end of the bandage. [Insert testing methods]. **Results:** [Insert testing results]. **Conclusions:** [Insert conclusions].

Introduction

Annually, more than 100,000 mastectomies are performed in the United States; either as a breast cancer treatment or as preventative action (1). Following mastectomy surgeries, a surgical drain is typically placed to prevent a build-up of fluid, or a seroma, from forming in the body. Seromas occur when there is a collection or build-up of fluid in an open space or pocket below the skin (2), such as when fluid leaks from damage to the lymphatic system to the space where tissue has been removed through surgery (3). Seromas can harm the natural healing process of the surgical wound, as the buildup of fluid causes the flaps of the chest wall to elevate and interferes with the skin's adherence to the tissue bed. This can cause dangerous complications such as delayed wound healing, wound infection, hematoma, flap necrosis, wound reopening, increased hospitalization time, delayed recovery time, and a risk of wound infection which can cause an abscess (4). The most effective postoperative way that seromas can be prevented is through the use of surgical drains (5).

Surgical drains are secured using many different methods based on the surgeon's preference and the equipment available. However, by and large, the most common method involves using sutures. Sutures are tied with various techniques (6–10), but they will all encounter the same patient comfort issue of tugging on the sutures. Tape (9) or disposable adhesive devices (11–13) may be used in place of sutures to increase patient comfort. These techniques, though, only last for approximately a week before requiring removal as the adhesive wears down. This is an issue when the drain must be in place for extended periods, as drainage must consistently be less than 25-30 mL of fluid a day before removal, which can take up to 1-5 weeks (14,15). Therefore, a new method of fixing surgical drains to the body in conjunction with sutures will be developed to increase patient comfort when a long-term drain is placed.

Materials and Methods

BANDAGE SELECTION

To determine the ideal bandage, the mechanical properties of four different bandages were identified: a hydrocolloid dressing (Winner Medical Co. Ltd., Guangdong China); elastic therapeutic tape (SpiderTech Inc., Toronto, Ontario, Canada); the aforementioned elastic therapeutic tape with an overlaying waterproof adhesive (Nuanchu, Wuhan, China); and a silicone bandage (Medline, Wuhan, China). Because elastic therapeutic tape has fibers running in mainly one direction, both orientations parallel to and perpendicular to the fiber direction were tested to determine if it is an anisotropic material.

Poisson's ratio was measured by hand, and Young's modulus was determined using the MTS Criterion® Model 43 (MTS Systems®, Eden Prairie, MN, USA). From these, the shear modulus was calculated, and these mechanical properties were used to run finite element analyses (FEBio). The simulations compared maximum effective stress given a 20 N point load across both bandage material and bandage geometry.

FABRICATION

Market-available bandages were purchased and cut using a Cricut Maker 3 (Cricut, Inc., South Jordan, UT, USA).

The clips were printed using Formlabs Elastic Resin in a Formlabs 2 SLA 3D printer (Formlabs, Somerville, MA, USA). Different versions of the clips were printed with varying inside diameters beginning at 0.300 cm and incrementally increasing by 0.025 cm with the largest diameter being 0.400 cm (**Figure 1**). Four clips of each diameter size were printed.

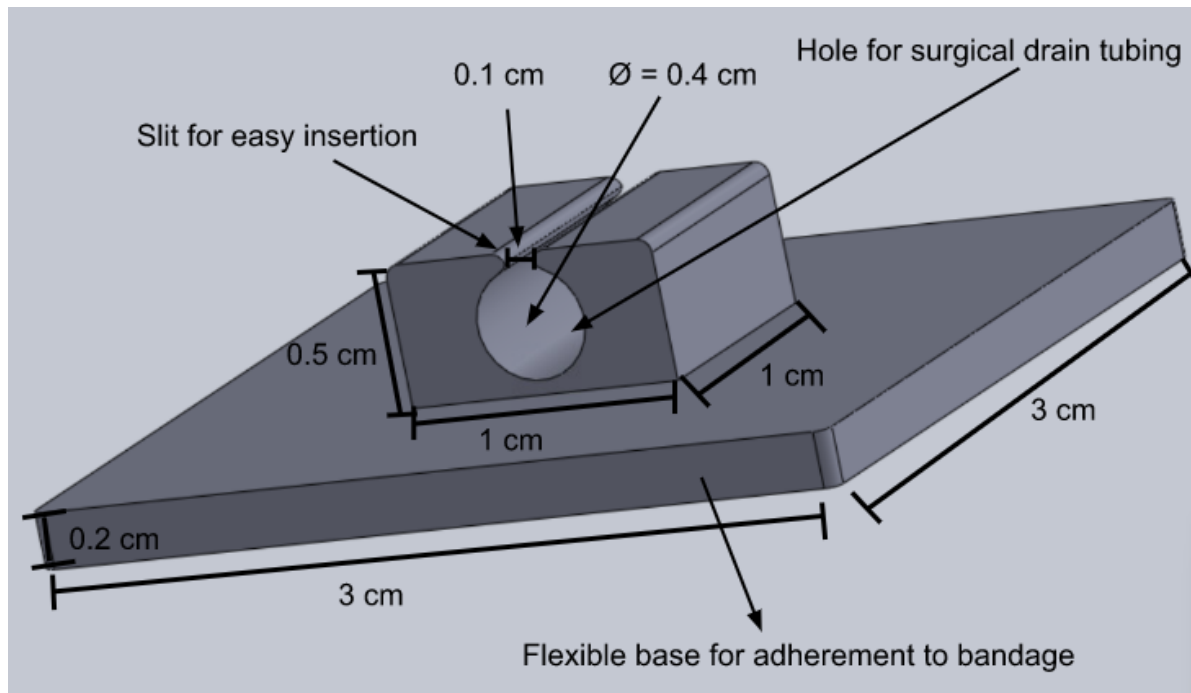

Figure 1: Clip design highlighting important features and dimensions.

SUPPORT STRENGTH TESTING

To determine which clip diameter can hold the most weight without displacement from the original position, the clips were adhered to a flat, vertical surface and the surgical drain tubing (Jackson-Pratt™ Silicone Flat Drain with a 100 mL Reservoir, CardinalHealth™, Waukegan, IL, USA) was secured in the clip. Water was pipetted into the drainage bulb and attached centrifuge tubes in 10 mL increments until the tubing slipped or there was obvious displacement. Grip-Lok® (TIDI Products, Neenah, WI, USA) was also tested utilizing this same method as a comparison to a product on the market.

FLOW TESTING

A flow test was done to ensure that the clip does not compress or block the surgical drain. Both water and a corn syrup-water mixture were tested to mimic the viscosity of blood. The corn syrup mixture was made by mixing 3 parts of light corn syrup (Essential Everyday®, Unfi Providence, Rhode Island, USA) and 1 part of water. Food coloring (3-4 drops) was also added to help visualize the fluid flow. Testing was done by attaching one end of drain tubing to a vacuum pump in the SterilGard® III Advance (The Baker Company, Sanford, Maine, USA) to mimic the vacuum that occurs when the drain is in the body. The amount of time it took to vacuum 30 mL of water through the tube while it was placed in the clip was recorded. To standardize this data, the flow velocity was calculated by dividing the distance the fluid traveled by the time it took to vacuum the water through the tube. This process was repeated using 20 mL of the corn syrup mixture to mimic the behavior of blood.

BANDAGE WEAR TESTING

[To be determined]

STATISTICAL ANALYSIS

MATLAB was used to perform statistical analyses. Analysis of Variance (ANOVA) was used with a significance level of 0.05 to determine significant differences for all testing. If significance was found, then a multiple comparisons test was performed using Tukey's honestly significant difference.

Results

BANDAGE SELECTION

The maximum effective stress per bandage material as calculated by FEBio is shown in **Figure 2**. ANOVA showed a significant difference between at least two of the groups ($p=0.0114$, $F=6.64$, $df=2$), and multiple comparisons of means revealed a significant difference between the elastic therapeutic tape and waterproofed elastic therapeutic tape ($p=0.0105$). The hydrocolloid bandage was not significantly different from the elastic therapeutic tape ($p=0.5815$) nor the waterproofed elastic therapeutic tape ($p=0.0643$).

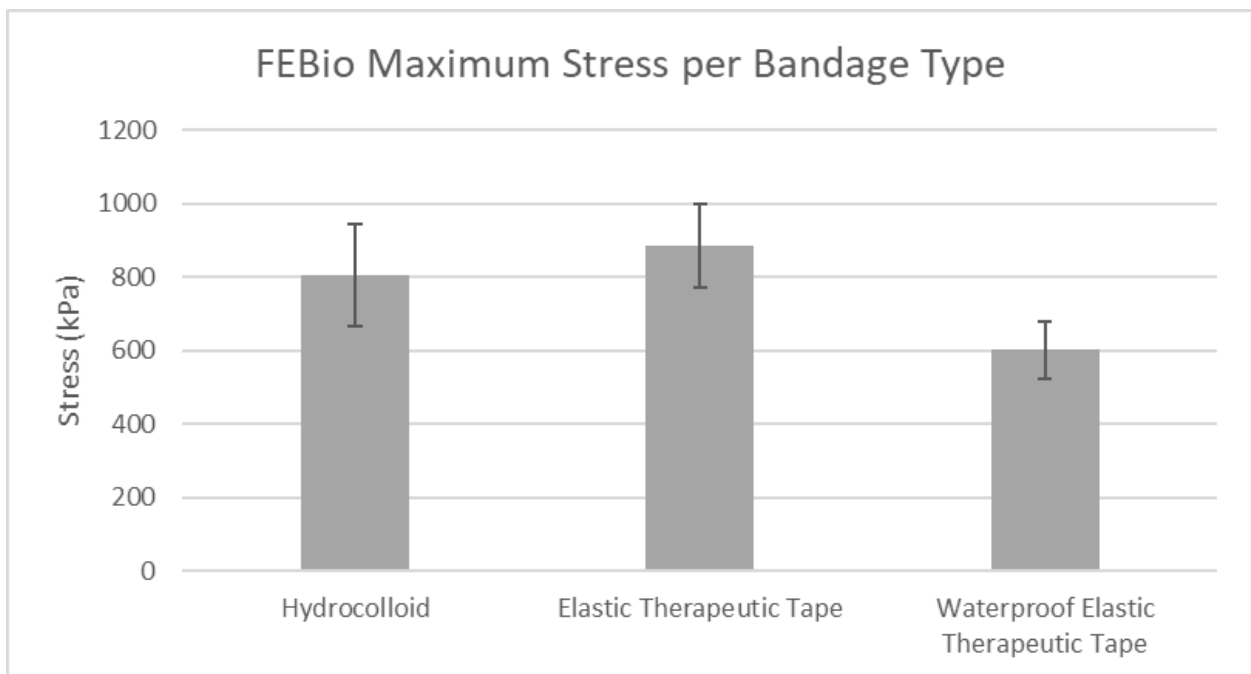

Figure 2: The average maximum effective stress per bandage material as calculated by FEBio given a 20 N point load. A significant difference existed between at least two of the groups ($p=0.0114$, $F=6.64$, $df=2$), and multiple comparisons of means revealed a significant difference between the elastic therapeutic tape and waterproofed elastic therapeutic tape ($p=0.0105$). The hydrocolloid bandage was not significantly different from the elastic therapeutic tape ($p=0.5815$) nor the waterproofed elastic therapeutic tape ($p=0.0643$).

The maximum effective stress per bandage geometry as calculated by FEBio is shown in **Figure 3**. ANOVA showed no significant difference between any of the groups ($p=0.8224$, $F=0.37$, $df=4$).

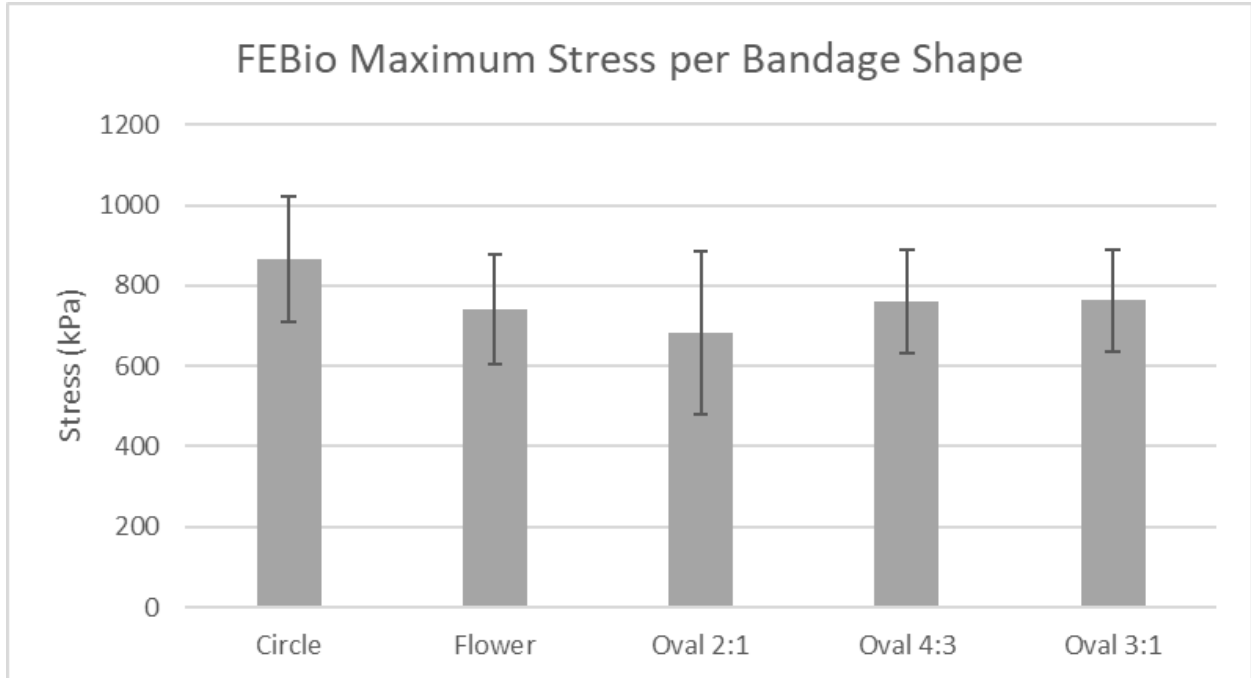

Figure 3: The maximum effective stress per bandage geometry as calculated by FEBio. Oval geometries are given as a ratio of the major axis to the minor axis. No significant difference existed between any of the groups ($p=0.8224$, $F=0.37$, $df=4$).

SUPPORT STRENGTH TESTING

The average mass supported per attachment method is shown in **Figure 4**. ANOVA revealed a significant difference between at least two of the groups ($p<0.001$, $F=14.92$, $df=5$). Multiple comparisons of means showed the 0.300 cm clip was significantly different than the 0.325 cm clip ($p=0.0095$), the 0.350 cm clip ($p<0.001$), the 0.375 mm clip ($p=0.0019$), the 0.400 cm clip ($p<0.001$), and Grip-Lok® ($p=0.0065$). The 0.400 cm clip was also significantly different from the 0.325 cm clip ($p=0.0043$) and Grip-Lok® ($p=0.0212$).

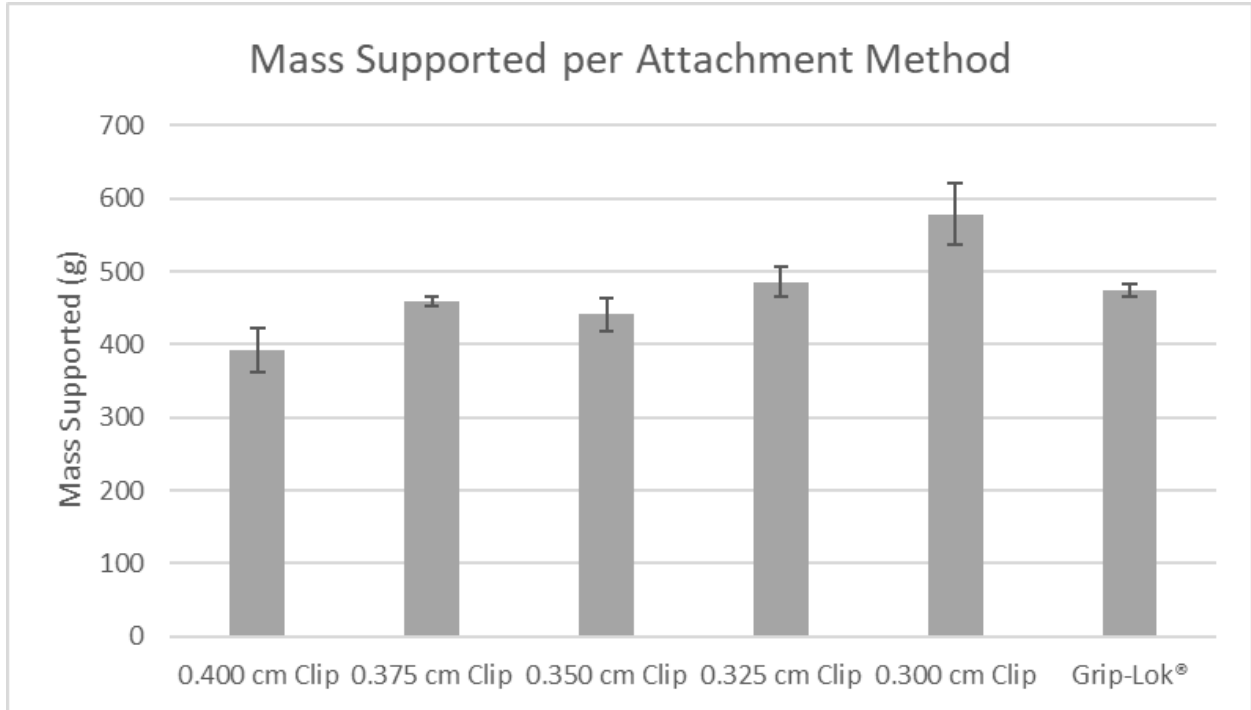

Figure 4: The average mass supported per attachment method. A significant difference exists between the 0.300 cm clip and the 0.325 cm clip ($p=0.0095$), the 0.350 cm clip ($p<0.001$), the 0.375 cm clip ($p=0.0019$), the 0.400 cm clip ($p<0.001$), and Grip-Lok® ($p=0.0065$). The 0.400 cm clip was also significantly different from the 0.325 cm clip ($p=0.0043$) and Grip-Lok® ($p=0.0212$).

FLOW TESTING

The average flow velocity of water and the corn syrup-water mixture through clips with varying interior diameters is shown in **Figure 5**. ANOVA showed no significant difference when water flowed through the drain ($p=0.9502$, $F=0.18$, $df=4$), but a significant difference existed between at least two of the groups when the corn syrup-water mixture flowed through the drain ($p<0.001$, $F=28.25$, $df=4$). Multiple comparisons of means revealed the 0.300 cm clip had a significantly different flow velocity than the 0.325 cm clip ($p<0.001$), the 0.350 cm clip ($p<0.001$), the 0.375 cm clip ($p<0.001$), and the control (no clip) ($p<0.001$).

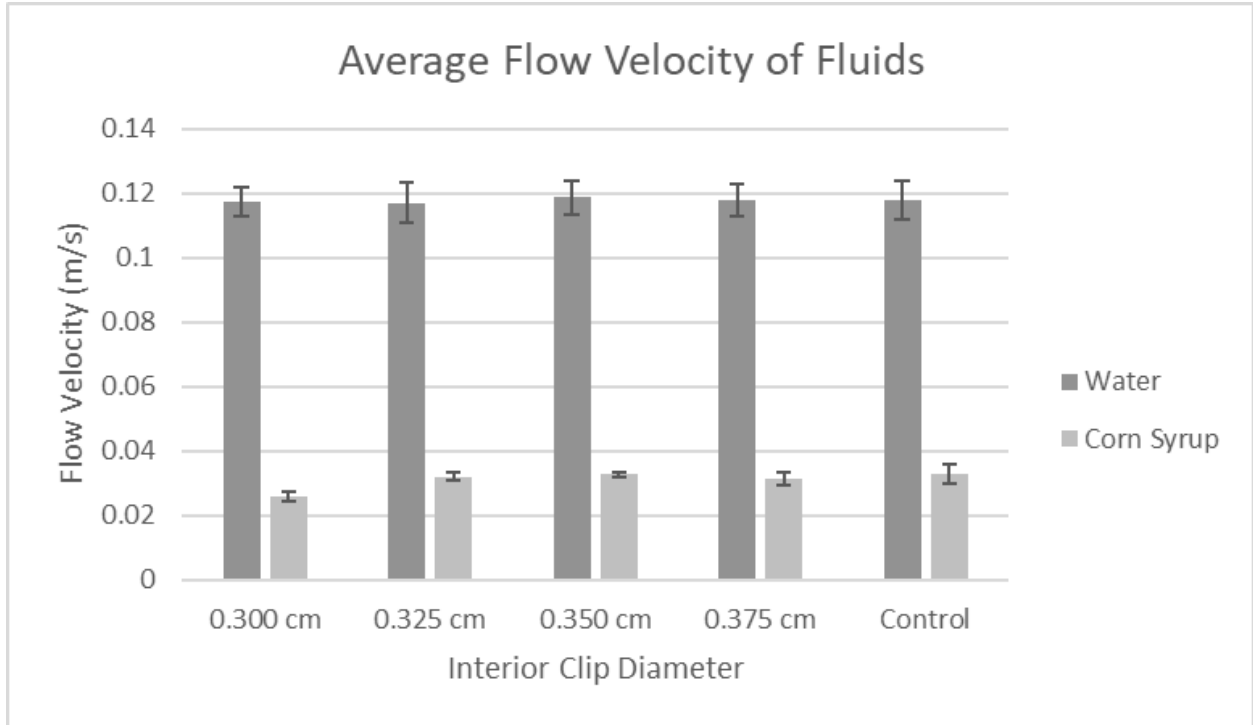

Figure 5: The average flow velocity of water and the corn syrup-water mixture through clips with varying interior diameters. No significant difference existed when water flowed through the drain ($p=0.9502$, $F=0.18$, $df=4$), but a significant difference existed between at least two of the groups when the corn syrup-water mixture flowed through the drain ($p<0.001$, $F=28.25$, $df=4$). Multiple comparisons of means revealed the 0.300 cm clip had a significantly different flow velocity than the 0.325 cm clip ($p<0.001$), the 0.350 cm clip ($p<0.001$), the 0.375 cm clip ($p<0.001$), and the control (no clip) ($p<0.001$).

BANDAGE WEAR TESTING

[To be determined]

Discussion/Conclusion

[To be determined]

Acknowledgment

We thank Dr. Tracy Puccinelli for her advice and support throughout the entirety of the project.

Statement of Ethics

[To be determined]

Conflict of Interest Statement

The authors have no conflicts of interest to declare.

Funding Sources

Materials were funded by the Department of Biomedical Engineering at the University of Wisconsin - Madison.

Data Availability

[To be determined]

References

1. Mastectomy and Double Mastectomy - Brigham and Women's Hospital [Internet]. [cited 2023 Feb 27]. Available from:
<https://www.brighamandwomens.org/surgery/surgical-oncology/resources/mastectomy>
2. Marion L. Everything You Need to Know About Surgical Drains - Chicago Plastic Surgery [Internet]. Plastic Surgery of Chicago. 2020 [cited 2022 Oct 10]. Available from:
<https://www.plasticsurgeryofchicago.com/surgical-drains/>
3. Seroma: What Is It, Causes, Treatment, and More | Osmosis [Internet]. [cited 2022 Oct 10]. Available from: <https://www.osmosis.org/answers/seroma>
4. Agrawal A, Ayantunde AA, Cheung KL. Concepts of Seroma Formation and Prevention in Breast Cancer Surgery. *ANZ J Surg.* 2006;76(12):1088–95.
5. Janis JE, Khansa L, Khansa I. Strategies for Postoperative Seroma Prevention: A Systematic Review. *Plast Reconstr Surg.* 2016 Jul 1;138(1):240–52.
6. Tiwari A, McFarlane JP, Peters JL. A simple technique for securing surgical drains. *Injury Extra.* 2022 Nov;35(11):91–3.
7. O'flynn P, Akhtar S. Effective securing of a drain. *Ann R Coll Surg Engl.* 1999 Nov;81(6):418–9.
8. Heskin L, Cahill V, Filobos G, Regan P, O'Sullivan S, Bryan K. A new adaptation for a secure surgical drain placement and a comparison with four common drain fixation methods. *The Annals of The Royal College of Surgeons of England.* 2019 Jan;101(1):60–8.
9. Epomedicine. Techniques of Securing Surgical Drain to Skin (Drain Fixation) [Internet]. Epomedicine. 2021 [cited 2022 Oct 10]. Available from:
<https://epomedicine.com/surgical-skills/techniques-securing-surgical-drain-fixation/>
10. Ringel Y, Haberfeld O, Kremer R, Kroll E, Steinberg R, Lehavi A. Intercostal chest drain fixation strength: comparison of techniques and sutures. *BMJ Military Health.* 2020 Oct;167(4).
11. Yousefpour A, Gibbons AJ, Whear NM. A simple way of securing suction drains: Technical note. *British Journal of Oral and Maxillofacial Surgery.* 2006 Apr;44(2):161–2.
12. Disposable Drainage Tube Holder - Changzhou Haiers Medical Devices Co., Ltd. [Internet]. Hasmedicalstapler.com. 2018 [cited 2022 Oct 10]. Available from:
https://www.hasmedicalstapler.com/Disposable_Drainage_Tube_Holder
13. Tube Attachment Devices | Critical Care Products | Hollister US [Internet]. www.hollister.com. 2022 [cited 2022 Oct 10]. Available from:
<https://www.hollister.com/en/products/Critical-Care-Products/Tube-Securement/Tube-Attachment-Devices#>
14. Li WY. Dr. Li's Guide to Getting Drains After Surgery [Internet]. Surgical Seecrets. 2022 [cited 2022 Oct 10]. Available from:
<https://surgicalsecrets.com/blogs/articles/guide-to-getting-drains-after-surgery>
15. Campbell J. How To Take Care of Your Drains After Breast Surgery [Internet]. Verywell Health. 2021 [cited 2022 Oct 10]. Available from:
<https://www.verywellhealth.com/managing-your-surgical-drains-following-breast-surgery-4021630>

Appendix

DESIGN PROCESS

One method the team brainstormed to improve the fixation of surgical drains was a clip design that would be attached to an adhesive bandage. This adhesive bandage with a clip design would be used alongside the suture placed by the surgeon to hold the drain in place. The adhesive would be made from a hydrocolloid bandage, as they are designed to be worn for up to a week (1). The hydrocolloid bandage consists of an outer layer that would act as a barrier to protect the wound from bacterial contamination and foreign particles (1). The hydrocolloid adhesive layer would be used to absorb moisture from the wound and create a hydrogel that promotes healing (1). This bandage would be placed over the wound site and would encourage proper wound healing.

The clip design would be made from high-density polyethylene since this material absorbs little water and is typically used as a plastic material for most medical devices (1). The clip would be attached to a platform made from high-density polyethylene to allow for easy attachment to the adhesive portion of the design. This preliminary design can be seen in **Figure 1**.

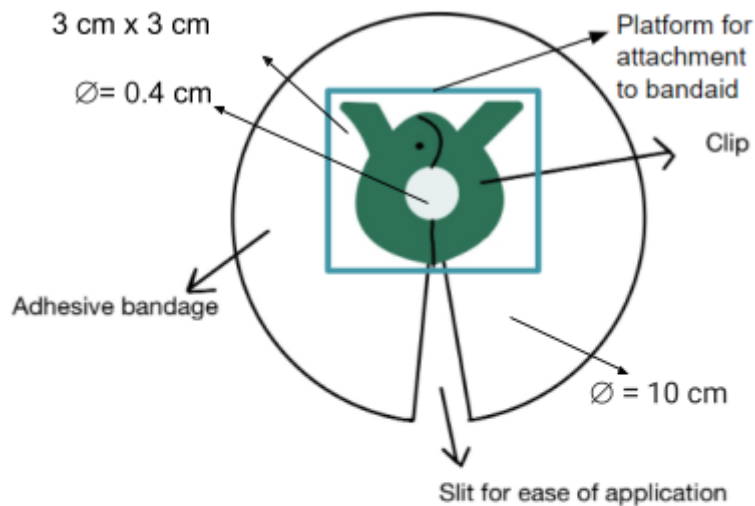

Clip mechanism



Figure 1: Drawing of the adhesive bandage with clip design placed at the drainage site. The clip would wrap around the surgical drain tubing exiting the patient's skin.

Another method the team brainstormed for securing the surgical drain would be to replace the use of sutures with another device. This device would consist of a rigid tube that would be made from high-density polyethylene to fit the diameter of the surgical drain tubing. The high-density polyethylene was chosen since it is a rigid plastic that is biocompatible (2). The flaps would be made from silicone since silicone is a flexible material that is also biocompatible (3).

This device would be placed around the tubing of the surgical drain and implanted when the surgeon places the surgical drain. The flaps would be pulled up and flattened to allow them to be placed into the wound site as seen in **Figure 2**. Once the device is placed under the skin, the rigid tube would be pulled up to allow the silicone flaps to flatten out underneath the skin as seen in **Figure 3**. Each flap would be used to distribute the pressure under the skin in different spots. A locking tie or clip would be wrapped along the edge of the tube outside the body to prevent the tube from getting pushed back further into the patient's body, and to prevent the displacement of the device. This device would remain in place for the entire duration the surgical drains would need to be in place. This device is not adjustable as it would be slid on once the drain is in place and multiple sizes would need to be created to accommodate different drain sizes.

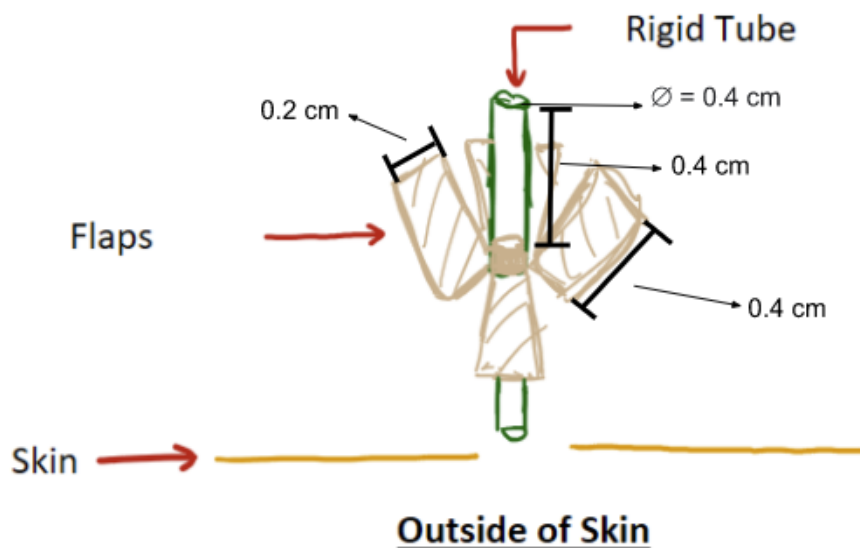

Figure 2: The silicone flaps in their upright position against the rigid tube for insertion at the wound site.

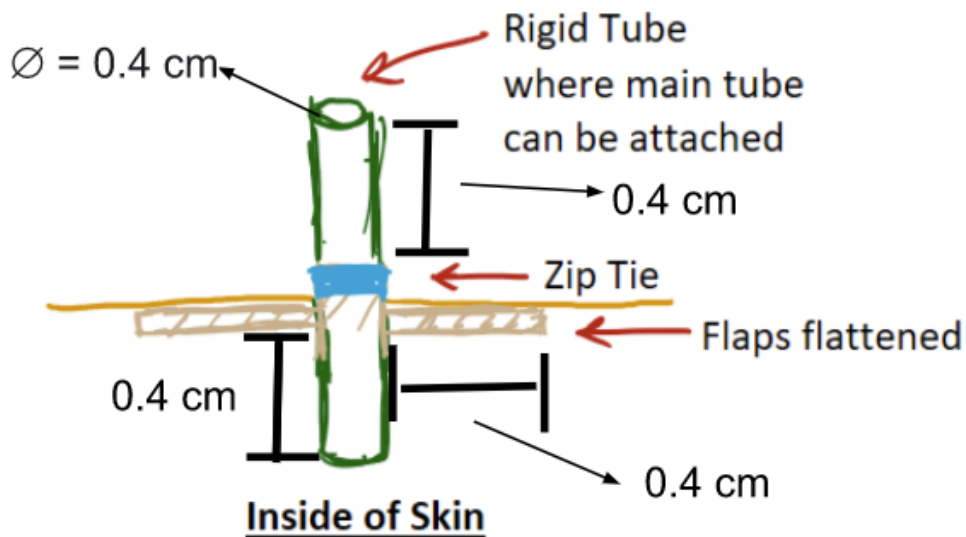

Figure 3: The silicone flaps are flattened underneath the skin with a tie around the rigid tube to hold the device in place outside the patient's skin.

The third design would be used alongside the sutures that the surgeon typically uses to hold the drain in place. This design consists of pressure-distributing flaps made from a material similar to elastic therapeutic tape. Elastic therapeutic tape is made from a cotton-woven base that allows for a more breathable bandage (4). Elastic therapeutic tape is very porous allowing for moisture to seep through the bandage, preventing the degradation of the adhesive material (4). This would allow for the elastic therapeutic tape to remain in place for up to a week at a time. This is ideal for this project as this will reduce the cost of the device and allow for the patient to continue to do daily activities such as showering and physical therapy exercises that may be assigned by their doctor without having to constantly replace the tape. Each flap would distribute the pressure evenly on the patient's skin away from the suture site.

The silicone ring of the design would be used to hold the drain securely in place. Silicone was chosen for this as it is very flexible and will not compress the surgical tube enough to stop the flow of fluid out of the drain (5). The gauze padding would be placed on the underside of the adhesive where the wound site and suture site are as can be seen in **Figure 4**. This ensures that the wound site and suture are not being tugged on by the adhesive material.

This design would be beneficial in distributing the pressure evenly on the patient's skin. The elastic therapeutic tape material is not waterproof and this means the patient would have to replace it when showering or when it begins to fall off. This would increase the cost of this design.

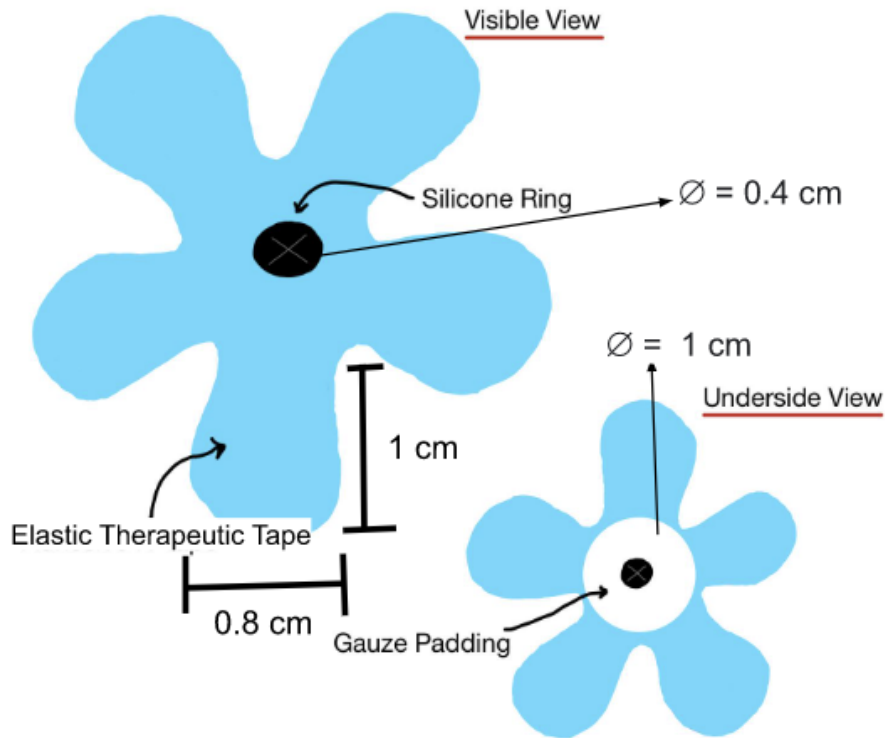

Figure 4: The pressure-distributing adhesive flaps with a top and bottom view.

To evaluate the three designs that were brainstormed the team created a design matrix (**Figure 5**). The criteria for the designs were ranked in importance based on the client's needs. Effectiveness was ranked the highest because the design needs to be able to hold the surgical drain tubes in place and prevent any displacement from occurring. Patient comfort was ranked next, as this is emphasized by the client as a problem with the current method of attaching surgical drains to a patient. This criterion is scored on how comfortable the design will be once it is installed on the patient. Additionally, it was rated on how well the design will ideally be able to alleviate the pain that occurs at the wound site. Ease of use was described as how easily the design can be installed and the amount of maintenance required once it is installed. The cost was then used to assess the necessary expenses to fabricate and maintain the design. Lastly, adaptability was used to analyze how well the design can be used in various locations on the patient's body.

		 Adhesive Bandage with Clip		 Interior Pressure Distributing Flap		 Exterior Pressure Distributing Flap	
Criteria	Weight	Score (10 max)	Weighted Score	Score (10 max)	Weighted Score	Score (10 max)	Weighted Score
Effectiveness	30	8	24	6	18	8	24
Patient Comfort	25	8	20	3	8	9	23
Ease of Use	20	7	14	9	18	6	12
Cost	15	8	12	9	14	6	9
Adaptability	10	10	10	7	7	8	8
Sum	100	Sum	80	Sum	66	Sum	76

Figure 5: The preliminary design matrix.

Based on the criteria in the design matrix, the adhesive bandage with clip design and pressure-distributing flaps outside scored highest for effectiveness. This is because the two designs would still implement sutures to attach surgical drains (6). Both designs would increase the stability and support of the surgical drains at the wound site. For patient comfort, the pressure-distributing flaps scored the highest due to its use of elastic therapeutic tape which would help with comfort and disperse the pressure when surgical tubes were tugged on. The second design scored low because some components would be under the skin, which could cause pain if the tubes were tugged on. In addition, inflammation could occur due to foreign body reactions of the silicone flaps going under the skin (7). As for ease of use, the second design scored the highest since it does not require sutures to attach the tubes and requires little maintenance once it is installed. This is different from the first and second designs because these designs require the need for sutures and adhesives which would need to be changed daily. This reasoning is also applied to the cost criterion resulting in the second design scoring the highest. Lastly, for the adaptability criterion, the first design scored the highest. This is because this design uses a clip mechanism that is adjustable for the use of different-diameter drains.

After analyzing each design using the criteria generated above the adhesive bandage with clip design was chosen as the final design. This design was chosen because of its ability to provide added support

for the surgical drain tubes at the wound site and prevent their displacement. In addition to the added support, this design can relocate the tension that occurs at the suture site to lessen the discomfort that the patient experiences.

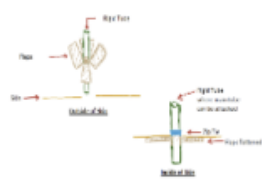
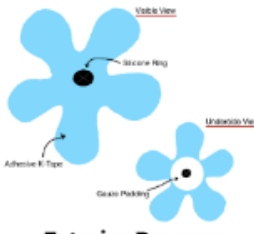
Once the final design was decided upon, the team began fabricating and testing. To begin the fabrication process, the team obtained a set of large hydrocolloid bandage sheets. After testing various geometries in FEBio, it was determined that the geometry of the bandage does not have a significant effect on force distribution. The team decided to proceed with an oval shape to allow for a greater distance between the clip and drain site.

Methods to fabricate the correct shape of the hydrocolloid bandage involved the use of a Cricut Maker 3. The use of the Cricut machine allowed precise and uniform cuts of the bandage. The bandage shape, drain tube opening, and slit for easy application were all created using this fabrication method. The proposed clip design (**Figure 6**) was rendered in Solidworks and printed in the UW Makerspace using a Formlabs Form 2 SLA printer. The clip was printed with an elastic resin, allowing for a structured clip with moderate flexibility to accommodate different tubing diameters.

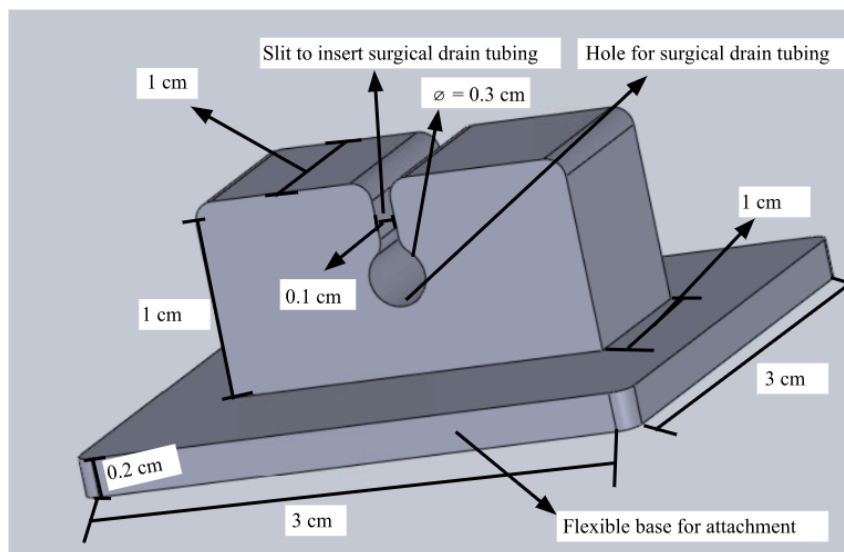

Figure 6: Clip design with dimensions.

The complete bandage assembly process involved the attachment of the clip to the bandage. For prototyping and testing, the clip was adhered to the bandage using a generic cyanoacrylate adhesive. The use of a non-medical grade adhesive was used to create a prototype for proof of concept rather than for medical-grade patient use (**Figure 7**).

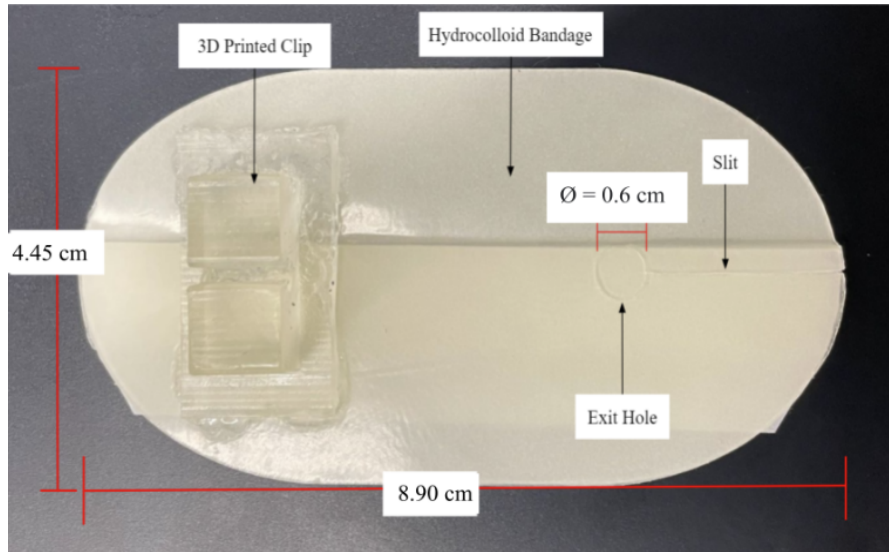

Figure 7: Top view of the prototype with highlighted features and dimensions.

After re-evaluating the prototype, the team decided to reconsider the method of adhering the clip to the bandage. The team has contacted employees at 3M and Mölnlycke for ideas for creating a double-layer adhesive to secure the clip to the hydrocolloid bandage. The team has also made progress on creating new clip iterations that consist of 4 different diameters (0.300 cm, 0.325 cm, 0.350 cm, 0.375 cm, and 0.400 cm). The new clip design is also less bulky compared to the previous design as the dimensions around the insertion point for the surgical drain tubing have been reduced. To determine which clip will secure the surgical drain tubing the best without impinging on the flow of the fluid through the tubing strength testing has been performed on all the new clip iterations as well as flow testing utilizing water and a corn syrup-water mixture to mimic the viscosity of blood. The team has also reached out to the IRB regarding human testing but is still in the process of getting approval. The next testing plans include a sweat and water test to mimic normal daily activity and showering respectively. The team also plans to complete adhesive testing which will consist of determining how much pressure is required to remove the bandage as well as how long it can remain in place. Once all testing is completed and all results are analyzed the team will create a new final prototype with the new clip design (**Figure 8**).

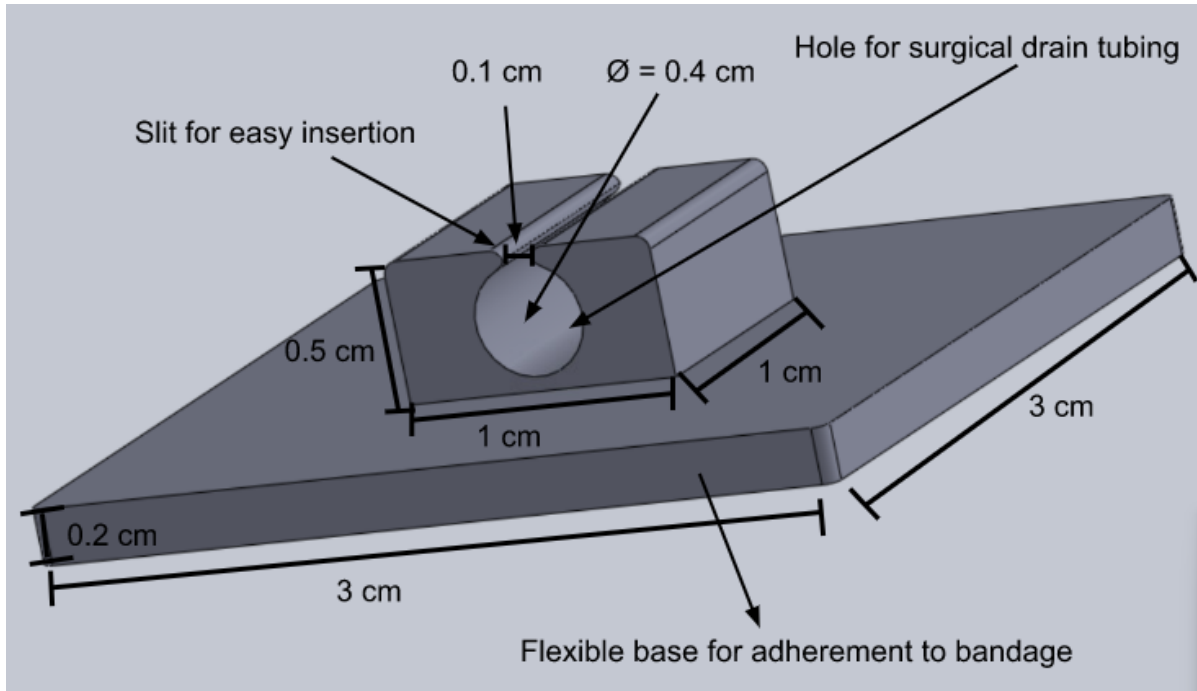

Figure 8: Most recent iteration of the clip design with 0.400 cm diameter. The clip is less bulky to reduce the probability of tugging on clothing and has a more flexible base.

References

1. Barnes HR. Wound care: fact and fiction about hydrocolloid dressings. *J Gerontol Nurs.* 1993 Jun;19(6):23–6.
2. Dewing J. Medical Devices Equipment: What Plastic Materials Are Used in Them? [Internet]. *Proto Plastics.* 2022 [cited 2022 Oct 10]. Available from: <https://protoplastics.com/plastic-materials-medical-devices-equipment/>
3. França DCC, de Castro AL, Soubhia AMP, de Aguiar SMHCÁ, Goiato MC. Evaluation of the Biocompatibility of Silicone Gel Implants – Histomorphometric Study. *Acta Inform Medica.* 2013;21(2):93–7.
4. Tunakova V, Tunak M, Mullerova J, Kolinova M, Bittner V. Material, structure, chosen mechanical and comfort properties of kinesiology tape. *J Text Inst.* 2017 Dec 2;108(12):2132–46.
5. Zare M, Ghomi ER, Venkatraman PD, Ramakrishna S. Silicone-based biomaterials for biomedical applications: Antimicrobial strategies and 3D printing technologies. *J Appl Polym Sci.* 2021;138(38):50969.
6. Tiwari A, McFarlane JP, Peters JL. A simple technique for securing surgical drains. *Injury Extra.* 2022 Nov;35(11):91–3.
7. Carnicer-Lombarte A, Chen ST, Malliaras GG, Barone DG. Foreign Body Reaction to Implanted Biomaterials and Its Impact in Nerve Neuroprosthetics. *Front Bioeng Biotechnol* [Internet]. 2021 [cited 2022 Oct 10];9. Available from: <https://www.frontiersin.org/articles/10.3389/fbioe.2021.622524>

TESTING PROTOCOLS

1. MTS Testing for Tensile Properties and Elastic Modulus

Detailed Steps of Testing:

1. Set up the MTS machine for tensile testing.
 - a. Use 100N rubber tensile grips unless otherwise specified by the instructor.
2. Obtain the bandages for testing (elastic therapeutic tape, hydrocolloid bandage, silicone bandage, elastic therapeutic tape with waterproofing).
3. Cut each sample of each bandage type into a bone shape.
 - a. Bone shape size should be consistent between each material sample.
4. Load a bandage, testing in the direction of the fibers.
5. Perform a tensile test to failure.
6. Record the elastic modulus.
7. Repeat steps 3-5, loading the bandage with fibers in the perpendicular direction.
8. Repeat steps 3-6 using the next bandage.

2. Testing for Poisson's Ratio and Shear Modulus

Detailed Steps of Testing:

1. Draw or stamp a perfect square onto the bandage. Record its dimensions.
2. Stretch the bandage using a uniaxial load. Record the square's dimensions.
3. Repeat step 2 with the load applied in the perpendicular direction.
4. Calculate Poisson's ratio ($\frac{\text{lateral deformation}}{\text{longitudinal deformation}}$) in both directions.
5. Assume elastic modulus and Poisson's ratio is the same in either perpendicular direction.
6. Calculate the shear modulus in three directions ($E=2G(1+\nu)$).

3. FEBio Simulation

Detailed Steps of Testing:

1. Create different geometries of the bandage in SolidWorks. Export as .STEP files.
2. Open the model in FEBio.

3. Set the material (orthotropic elastic) and its properties (density, elastic modulus in three directions, shear modulus in three directions, and Poisson's ratio in three directions).
4. Set the boundary condition to be on the adhesive surface, constrained in all directions.
5. Set the load at the clip location as a pressure surface load. Set the scale (as stress).
6. Optimize the mesh to find the one that has the best performance with the fewest elements.
7. Analyze the stress distribution using the optimized mesh.
8. Repeat steps 2-7 using each geometry.
9. Compare the distributions and the maximum stresses in each geometry. Choose the geometry that minimizes the maximum stress.

4. Force Testing Protocol

Detailed Steps of Testing:

1. Gather eight hydrocolloid bandages, four with Grip-Lok® and four with the clip attached to them.
2. Gather uniform weights.
3. Adhere the bandage to a clean vertical surface with the hole with the slit facing up.
4. Secure the surgical drain tube to the bandage using either the Grip-Lok® or the clip.
5. Draw a line on the surgical drain tube relative to the top edge of the mechanism holding it in place.
6. Attach the weight to the surgical drain tubing using tape.
 - a. If no weights are available, fill the surgical bulb with 10 ml of water at a time by pipetting it into the opening of the bulb.
 - b. If additional weights are needed 50 ml centrifuge tubes can be taped onto the bulb and 10 ml can be added at a time.
7. Release the weight and allow it to hang freely.
8. Record the weight and displacement of the surgical drain.
 - a. Measure the displacement from the line on the tubing to the top edge of the mechanism holding the drain in place.
9. Repeat steps 3-8 using an increased amount of weight until failure (bandage falls, tube falls out of attachment device, or something tears/breaks) and record the weight of failure.
 - a. Determine the weight added by using the density conversion of water.

i. $1 \text{ g/ml} \times 10 \text{ ml} = 10 \text{ g}$ for every 10 ml added.

10. Repeat steps 3-9 using another bandage.

5. Mock Flow Testing- Tube Impingement and Drainage Capability

Artificial Fluid Creation:

1. 3 Parts Light Corn Syrup
2. 1 Part Tap Water
3. 3 Drops of Food Coloring (easier to visualize fluid flow)

Detailed Steps of Testing:

1. Measure 40mL of water into a small beaker.
2. Remove the bulb from the end of the surgical drain apparatus, place the drainage end in the beaker, and secure the open end to the vacuum pump in the biosafety cabinet.
3. Time duration needed to drain 30 mL of the beaker through the tube and into the vacuum.
4. Repeat steps 1-3 two more times to obtain three baseline readings.
5. Repeat steps 1-3 three times each for clips of 3mm, 3.25mm, 3.5mm, and 3.75mm diameters.
6. Repeat the same procedure with 30 mL of the artificial fluid.
7. Analyze obtained data for statistical significance.