

MRI compatible motion platform

Date: 04/12/2024 – 04/18/2024

Client: Jiayi Tang

Advisor: Dr. Trevathan

Team:

Maxwell Naslund

Caspar Uy

Kendra Besser

Jamie Flogel

Amber Schneider

Problem statement

MRI phantoms used to test and calibrate MRI's are often static models of the human body. These static models don't give a good representation of the constant motion created from natural processes such as respiratory and digestive functions. To solve this, our team will work on a MR compatible device that will hold a phantom and simulate the movements found within the human body.

Brief status update

The team was able to meet with our client this week to conduct some preliminary testing of the prototype in an MR environment. The prototype was successfully deemed MR compatible and was able to withstand the testing. The team also met later in the week to conduct more rigorous testing of the device's abilities outside of the MR environment. The team also spent time to finish the outreach reflection, and to make some final tweaks to the prototype for best functionality.

Difficulties / advice requests

N/A

Current design

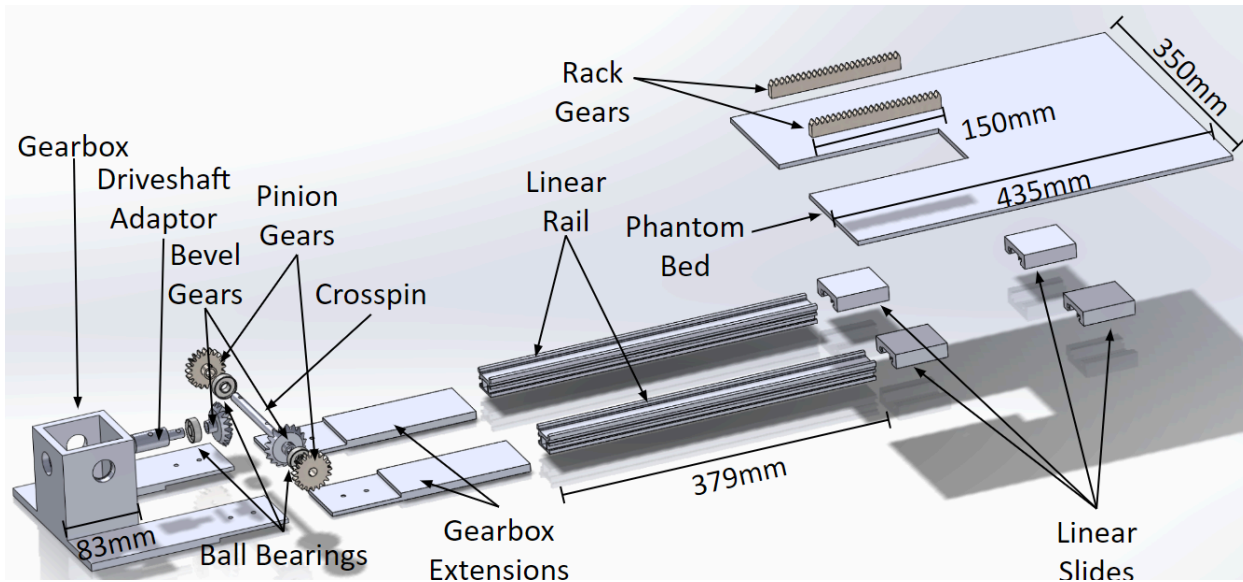

Materials and expenses

Item	Description	Manufacturer	Part Number	Date	QTY	Cost Each	Total	Link
Component 1								
Ultimaker PLA (118 g)	3D printed support for the driveshaft	Ultimaker	RAL-9005	11/17/2023	1	\$9.44	\$9.44	N/A
Ultimaker PLA (126 g)	3D printed gearbox extension pieces	Ultimaker	RAL-9005	2/27/2024	1	\$6.30	\$6.30	N/A
Ultimaker PLA	3D Printed Gears	Ultimaker	RAL-9005	3/7/2024	1	\$2.56	\$2.56	N/A

Ultimaker PLA	3D Printed Gearbox and motor stand	Ultimaker	RAL-9005	3/14/2024	1	\$19.60	\$19.60	N/A
Component 2								
Linear Rails	400 mm linear rails	igus	CWS-06-30-4 00	11/13/2023	2	\$167.69	\$335.38	Link
Component 3								
Linear Slides	Slides to support platform on linear slides	igus	WWPL-06-30 -06	11/13/2023	2	\$18.25	\$36.50	Link
Component 4								
Driveshaft	Connection piece between motor and gearbox	Grainger	H0400075PW 1000	11/16/2023	1	\$8.00	\$8.00	Link
Component 5								
Platform	1/4 black acrylic sheet provided by Makerspace	MSC	MSC# 63391700 (no part number given similar example)	11/17/2023	1	\$20.00	\$20.00	N/A
Component 6								

Glass Ball Bearings	Glass ball bearings to allow for frictionless rotation	Grainger	MSN0459939	12/1/2023	5	\$17.07	\$85.35	N/A
Component 7								
M5 Plastic Screws	Used to assemble final prototype	Grainger	50M050080 H016	2/15/24	1	\$1.65 per package of 25	\$1.65	Link
M4 Plastic Screws	Used to assemble final prototype	Grainger	50M040070N 035	2/15/24	2	\$5.92 per package of 25	\$11.84	Link
Plastic Screws and Nuts	Plastic hardware from the makerspace	Makerspace	N/A	3/6/2024	1	\$1.30	\$1.30	N/A
Component 8 Power Components								
Power Inverter	Power supply inverter to improve circuit	DigiKey	PDM1-S5-D3 -S	3/22/2024	2	\$5.12	\$10.24	Link
Component 9 - unused features due to reprints/redesigns								
Ultimaker PLA	3D printed Gearbox	Ultimaker	RAL-9005	10/26/2023	1	\$19.36	\$19.36	N/A
Ultimaker PLA	Motor to driveshaft adapter piece	Ultimaker	RAL-9005	12/1/2023	1	\$1.12	\$1.12	N/A

Ultimaker PLA	Motor to driveshaft adapter piece reprint	Ultimaker	RAL-9005	12/4/2023	1	\$2.84	\$2.84	N/A
Ultimaker PLA	Motor to driveshaft adapter piece reprint	Ultimaker	RAL-9005	12/5/2024	1	\$2.65	\$2.65	N/A
Ultimaker PLA (37.0 g)	3D printed gears to translate and facilitate motion	Ultimaker	RAL-9010	10/26/202 3	1	\$2.96	\$2.96	N/A
Ultimaker PLA (325.0 g)	3D printed gears and gearbox	Ultimaker	RAL-9005	11/03/2023	1	\$26.00	\$26.00	N/A
Bamboo Labs PLA (127.34 g)	3D printed gearbox extension pieces	Bambu Lab	#000000	11/15/2023	1	\$12.19	\$12.19	N/A
Ultimaker PLA (27 g)	3D printed racks	Ultimaker	RAL-9005	11/29/2023	1	\$2.16	\$2.16	N/A
Ultimaker PLA (126 g)	3D printed Motor Stand	Ultimaker	RAL-9005	12/01/202 3	1	\$10.08	\$10.08	N/A
Ultimaker PLA	3D printed gears and gearbox	Ultimaker	RAL-9005	2/23/24	1	\$14.60	\$14.60	N/A
TOTAL:	\$642.12							

Major team goals for the next week

1. Finish Senior Outreach reflection and Executive Summary
2. Test the prototype in the MR room
3. Update circuit and motor code
4. Continue adding material to GitHub

Next week's individual goals

- Max
 - Finish analysis of testing data
 - Write and practice my section of the poster
 - Meet with team to finalize poster
 - Finish ISMRM submission
- Amber
 - Finish testing and data analysis
 - Write my section of the poster and practice speaking part
 - Edit and print the poster
 - Begin working on final deliverables & ISMRM submission
- Jamie
 - Prepare poster for poster presentation
 - Wrap any last testing
 - Begin working on final deliverables
 - Finish ISMRM submission
- Kendra
 - Prepare poster for poster presentation
 - Complete any other necessary testing
 - Begin working on final deliverables
 - Finish ISMRM submission
- Caspar
 - Prepare poster for poster presentation
 - Complete last testing
 - Begin working on final deliverables
 - Finish ISMRM submission

Timeline

Task	Jan	Feb				March					April				May	
	26	2	9	16	23	1	8	15	22	29	5	12	19	26	3	10
Project R&D																
Empathize		X	X	X	X						X	X				
Background		X	X													
Prototyping			X	X	X	X	X	X	X		X					
Testing												X				
Deliverables																
Progress Reports		X	X	X	X	X	X	X	X		X	X				
Prelim presentation			X		X											
Final Poster																
Meetings																
Client		X					X				X					
Advisor	X	X	X	X	X	X					X	X				
Website																
Update	X	X	X	X	X	X	X	X	X		X	X				

Filled boxes = projected timeline
 X = task was worked on or completed

Previous week's goals and accomplishments

- Max
 - Team client meeting to perform MR room testing
 - Analyzed MR images for prototype validation
 - Met with team to conduct further testing outside of MR environment
 - Worked on outreach
- Amber
 - Evaluated platform for MRI safety at WIMR
 - Performed tests in MRI room
 - Finalized and submitted outreach forms
 - Performed motor and platform testing
 - Analyzed testing videos in Kinovea and created graphs
- Jamie
 - Met with client to perform MR room testing
 - Analyzed testing data from client
 - Performed sinusoidal waveform tests
 - Worked on outreach
 - Analyzed Kinovea data
- Kendra
 - Tested platform in MRI setting
 - Tested sinusoidal waveform and RPM tests with varying coefficients
 - Worked on ISMRM submission
 - Helped edit Design Excellence award submission
 - Completed individual section of outreach summary

BME Design: 402

- Caspar
 - Tested platform in MRI setting
 - Performed motor and platform testing
 - Worked on Outreach
 - Analyzed MR Images

Activities

Name	Date	Activity	Time (h)	Week Total (h)	Sem. Total (h)
Max	1/26/24	Semester planning with team	1.5	5	43
	1/31/24	Client meeting	0.5		
	2/2/24	Team meeting to review future fabrication	1.0		
	2/2/24	Team presentation assignments	0.5		
	2/6/24	Modeled future design in solidworks	1.5		
	2/6/24	Worked on preliminary presentation	1.0		
	2/7/24	Reviewed preliminary presentation with team	1.0		
	2/12/24	Reidentified desirable producible sinusoid	1.0		
	2/14/24	Met with team to order screws, and calculate gearing ratio	2.0		
	2/16/24	Team meeting to clarify torque transmission	1.0		
	2/20/24	Gearbox outputs algorithm	1.0		
	2/22/24	Watched MRI Safety Video	1.0		
	2/22/24	Solidworks modifications to gears	2.5		
	2/23/24	Drafted report and printed prototype with team	1.5		
	2/26/24	Wrote 'MRI-Compatible Motion Platform' section in 'Methods' & 'Results & Discussion' for Preliminary Journal entry	1.0		
	2/27/24	Edit Preliminary Journal with team	2.0		
	2/28/24	HIPPA Training	1.0		
	2/28/24	Reprint Gearbox	0.5		
	3/1/24	Checklist I Screening	1		
	3/6/24	Meeting to start gearbox assembly	2		
	3/7/24	Rack Solidworks redesign	1		
	3/11/24	Client Meeting	0.5		
	3/13/24	Team meeting to assemble gearbox	0.5		
	3/13/24	Gearbox redesign	2		
	3/15/24	Voltage divider design testing	2		
	3/20/24	Gearbox Assembly	2		
	4/3/24	Negative rail assembly	2		
	4/5/24	Worked with advisor to implement negative power rail	1.5		
	4/5/24	Met with team to connect to Keil Studio	1		
	4/11/24	Worked on low-pass gain filter	2		
	4/12/24	MR Testing with client	2		
4/16/24	Platform testing	2			
4/16/24	MR Image analysis	0.5			
4/17/24	Outreach reflection	0.5			
Amber	1/26/24	Semester planning with team	1.5	12.5	57
	1/31/24	Client meeting	0.5		
	2/1/24	Controls research	1.0		
	2/2/24	Review Motor Documentation	1.0		
	2/2/24	Create preliminary presentation slides	0.5		
	2/5/24	Implement changes to code	1.0		
	2/6/24	Draft PID algorithm	0.5		
	2/7/24	Review and practice preliminary presentation w/ team	1.0		
	2/14/24	Started MRI certification	0.50		

	2/15/24	Ran motor code test	0.50		
	2/15/24	Analyzed results	0.50		
	2/15/24	Updated code	0.50		
	2/16/24	Team meeting to clarify sinusoidal motion equation (Velocity & Position)	1.0		
	2/19/24	Meeting with Dr. Nimuncar to discuss sinusoidal motion function	0.5		
	2/20/24	Edited sinusoidal motion function	1.0		
	2/21/24	Tested & edited sinusoidal motion function	2.0		
	2/21/24	Watched GEHC MRI safety video	1.0		
	2/22/24	Test sinusoidal motion function	1.0		
	2/22/24	Background research on Journal Article	1.0		
	2/23/24	Drafted report and printed prototype with team	1.5		
	2/24/24	HIPPA Training	0.5		
	2/25/24	Wrote Motor and Testing sections of report	0.5		
	2/25/24	Competing Design Journal Research	0.5		
	2/27/24	Circuit Design Meeting	0.5		
	2/27/24	Edit Preliminary Report	2.0		
	2/28/24	Circuit Calculations	1.0		
	2/29/24	MRI Safety Book	1.5		
	3/1/24	Checklist I Screening	1.0		
	3/5/24	Circuit Testing	2.0		
	3/8/24	Circuit Testing w/ Team	1.5		
	3/11/24	Client Meeting	0.5		
	3/11/24	Circuit Redesign	1.0		
	3/15/24	Voltage Divider Circuit assembly & testing	2.0		
	3/19/24	Conversation with Tekceleo	0.5		
	4/2/24	Meeting with Client	0.5		
	4/3/24	Meeting with Team (executive summary & circuit construction)	2.0		
	4/4/24	Communication with Tekceleo	0.5		
	4/5/24	Team meeting to explain motor and assign new roles/tasks	1.5		
	4/5/24	Implement negative power rail w/ team & advisor	1.0		
	4/10/24	Ran RPM accuracy test	0.5		
	4/10/24	Updated GitHub with motor code documentation	2.0		
	4/11/24	Met with Tekceleo to discuss RMP accuracy concerns	1.0		
	4/11/24	Ran tests to calculate new RPM to Voltage conversion	1.5		
	4/11/24	Sinusoid testing with circuit	2.0		
	4/12/24	MRI testing at WIMR	2.0		
	4/16/24	Platform Testing & Finalize Outreach	2.5		
	4/16/24	Kinovea Analysis	1.0		
	4/17/24	Kinovea Analysis	2.5		
	4/18/24	Platform Testing, RPM Time test, and Kinovea Analysis	2.5		
Jamie	1/26/24	Semester planning with team	1.5	10.0	48.5
	1/31/24	Client meeting	0.5		
	1/31/24	Researched organ motion	0.5		
	2/2/24	Worked on Preliminary presentation	0.5		
	2/5/24	Completed budget slide	0.5		
	2/6/24	Completed timeline slide	1.0		

	2/7/24	Review and practice prelim presentation	1.0		
	2/8/24	Researched Plastic Screws	0.5		
	2/14/24	Met with team to order screws, and calculate gearing ratio	2.0		
	2/16/24	BPAG meeting	0.5		
	2/16/24	Team meeting to clarify torque transmission	1.0		
	2/21/24	Researched potential journals	1.5		
	2/21/24	Watched MRI Safety Video	1.0		
	2/22/24	Solidworks modifications to gears	2.5		
	2/23/24	Drafted report and printed prototype with team	1.5		
	2/26/24	Wrote characterization of motion and sinusoidal motion test sections of report	0.5		
	2/27/24	HIPPA Training	0.5		
	2/27/24	MRI safety reading	0.5		
	2/27/24	Edit preliminary report	2.0		
	3/1/24	Checklist I Screening	1.0		
	3/6/24	Meeting to start gearbox assembly			
	3/8/24	Circuit Testing w/ Team	1.5		
	3/11/24	Client Meeting	0.5		
	3/13/24	Began assembly of new prototype redesigned motor stand	1.5		
	3/14/24	Updated expense table	0.5		
	3/15/24	Voltage divider design testing	2.0		
	3/20/24	Gearbox Assembly	2.0		
	4/3/24	Meeting with Team (executive summary & circuit construction)	2.0		
	4/5/24	Team meeting to combine teams and redirect efforts	1.5		
	4/5/24	Worked on negative power rail with advisor	1.0		
	4/9/24	Worked on outreach	1.0		
	4/10/24	Created and updated GitHub	2.0		
	4/11/24	Updated Expenses	1.0		
	4/12/24	MR room testing	2.0		
	4/16/24	Sinusoidal Motion test & MR room data analysis	3.0		
	4/17/24	Kinovea Data Analysis	2.5		
	4/18/24	Kinovea Data Analysis cont.	2.0		
	4/18/24	Finalized outreach	0.5		
Kendra	1/26/24	Semester planning with team	1.5	8	40.5
	1/31/24	Client meeting	0.5		
	2/1/24	Researched transfer function	0.5		
	2/2/24	Review motor documentation	1.0		
	2/5/24	Edited preliminary slides	1.0		
	2/7/24	Review and practice prelim presentation	1.0		
	2/14/24	HIPPA training	0.5		
	2/26/24	Caught up on meetings	0.5		
	2/26/24	Downloaded, read, and ran new code	0.5		
	2/26/24	Wrote introduction to preliminary report	1.0		
	2/27/24	Circuit design meeting	0.5		
	2/27/24	Edited preliminary report	2.0		
	2/28/24	Watched MRI safety video	1.0		
	2/29/24	Read MRI safety manual	1.5		
	2/29/24	LP non inverting amp circuit equations	1.0		

	2/29/24	and circuit draft	2.0		
	3/1/24	Completed design journal research	1.0		
	3/4/24	MRI checklist screening	1.0		
	3/5/24	Gathered materials & built LP/ amp circuit	2.0		
	3/12/24	Circuit Testing	0.5		
	3/14/24	Catch up on meeting notes	1.0		
	3/15/24	New circuit calculations	2.0		
	3/19/24	Voltage Divider Circuit assembly & testing	0.5		
	4/2/24	Conversation with Tekceleo	1.0		
	4/3/24	Meeting with Client	2.0		
	4/4/24	Meeting with Team (executive summary & circuit construction)	0.5		
	4/5/24	Communication with Tekceleo	1.5		
	4/5/24	Team meeting to combine teams and redirect efforts	1.0		
	4/11/24	Worked on negative power rail with advisor	2.5		
	4/12/24	Meeting with Tekceleo	2.0		
	4/16/24	MR room testing	2.5		
	4/18/24	Sinusoidal Motion test	1.0		
	4/18/24	Sinusoidal and RPM testing with Amber			
Caspar	1-26-24	Semester planning with team	1.5	9.25	43.13
	1-31-24	Client Meeting	0.5		
	2-2-24	Researched organ movement in MRIs	0.75		
	2-2-24	Team Meeting	1		
	2-6-24	Worked on Presentation Slides	1.25		
	2-7-24	Preliminary Presentation team meeting	1		
	2-8-24	Researched Plastic Screws	0.75		
	2-14-24	Finalizing Plastic Screw and Nut	1.25		
	2-16-24	Research, Met to work on gearbox	1.0		
	2-17-24	Team Meeting	0.33		
	2-25-24	Journal Types Review	1.0		
	2-25-24	Preliminary Report	1.5		
	2-29-24	Watched MRI Safety Video	1.0		
	2-29-24	MRI Checklist Readings	1.0		
	3/1/24	MRI checklist Screening	1.0		
	3-6-24	Meeting to work on gearbox assembly	2		
	3-8-24	Circuit Testing and Screw modifying	2		
	3-11-24	Client Meeting	0.5		
	3-13-24	Began Assembly for next prototype	1.5		
	3-14-24	Worked on Driveshaft	2.5		
	3-20-24	Gearbox assembly	1.75		
	3-22-24	Worked on Driveshaft	2		
	4-5-24	Get briefed on Tekceleo and electronics team	1.5		
	4-9-24	Introduction to mBed and KeliStudio	2		
	4-10-24	KeliStudio learning	0.5		
	4-10-24	Research Capacitor Gain	0.75		
	4-11-24	Low Pass Filter Build Research	3		
	4-12-24	Team meeting and MR room	2		
	4-16-24	Platform Tests and Image analysis	2.25		
	4-16-24	Outreach Reflection and Editing	1		
	4-18-24	Team meeting on Executive summary	1		
	4-19-24	Team meeting on Final Deliverables	3		

