

Progress Report - Week 10

Title: Vaginal Self-Swab Device to Minimize Contact Contamination

Client: Dr. Jean Riquelme

Advisor: Dr. Megan McClean

Team:

Sara Morehouse (Leader)

Cherry Qiu (Communicator)

Katherine Kafkis (BWIG and BSAC)

Adam Berdusco (BPAG)

Date: April 11, 2024

Problem Statement:

Quality sexual health is important for every woman to sustain, but with women ages 15-24 accounting for 43% of undiagnosed STI cases, the system supporting women's sexual health could use some improvement (CDC). The team has developed a novel self-swab STI testing device that allows women the privacy of swabbing themselves without the potential discomfort of a physician present. This was conceived with the goal in mind of making STI testing more accommodating while reducing contamination of the testing environment. However, the current design has issues with media leaking from the device after use, as well as with the aesthetics of the design. Additionally, the device requires the addition of a thin, puncturable film to the cap to contain transport media. The team is tasked with modifying the original design to address the issues currently being faced while still seeking to limit contamination of the device and testing environment as well as account for patient comfort.

Brief Status Update:

This week the team worked on writing protocols for each of the four tests that will be performed. The tests we decided to conduct include a contamination testing, a 3-point bending test of the swab, a Solidworks simulation of tipping force for the media tube in the stand, and a survey of preference for a full-length or short handle design.

Current Design:

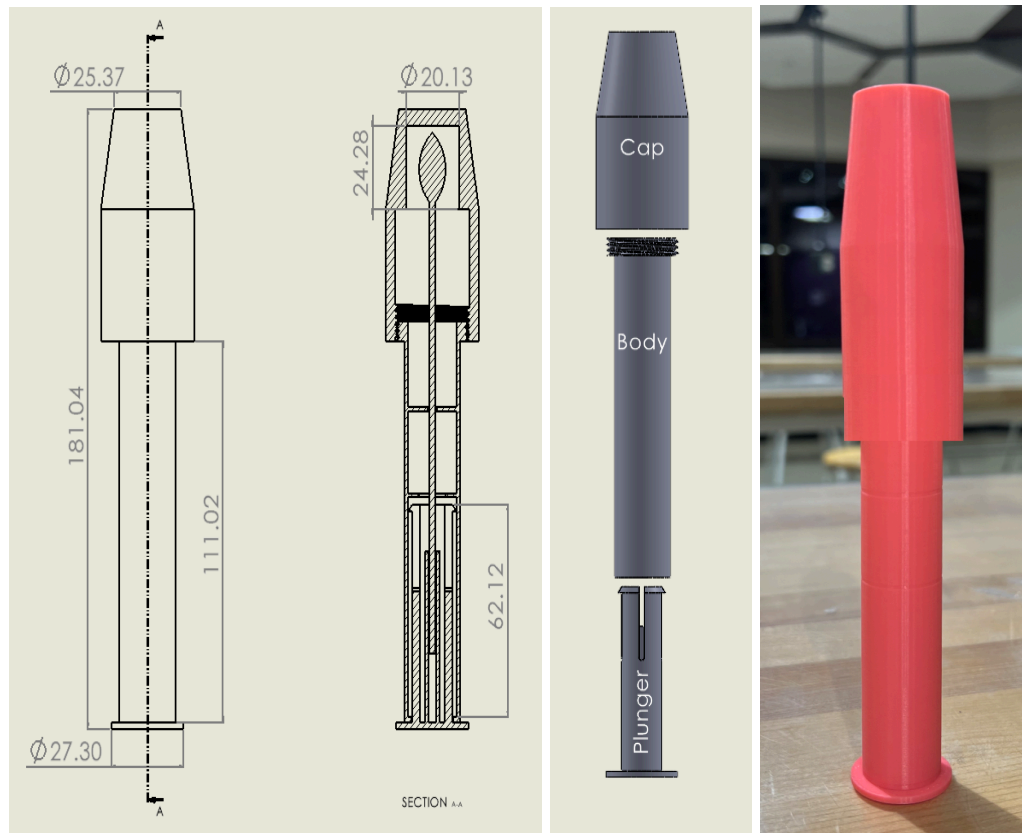

The current design was developed last semester and includes a plunger, body and cap. The prototype was 3D-printed and assembled with the plunger being inserted into the bottom of the body, and the cap screws onto the top of the body. A swab is inserted through the body and into the plunger.

New Design:

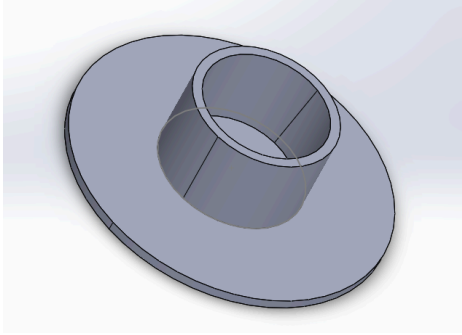

This component is a base to house the Aptima tube while the patient conducts the test.

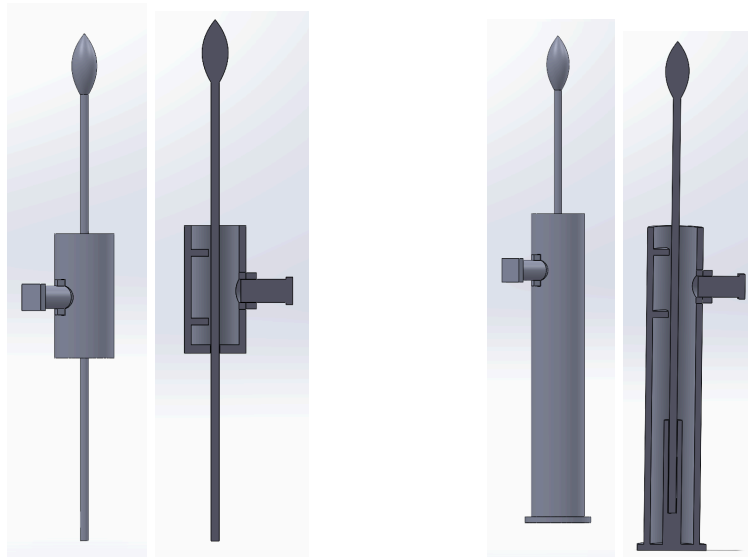

The left design utilizes 3-point bending to break the swab and uses a button to apply a central force at the swab perforation.

The right design is identical to the middle design except that it includes a full body that is the length of the swab and provides a base for it to stand up on.

Materials and Expenses:

Item	Description	Manufac - turer	Mft Pt#	Vendor	Vendor Cat#	Date	#	Cost Each	Total	Link
Preliminary prototype print	Material: PLA	n/a	n/a	Makerspace	n/a	2/27	n/a	n/a	\$3.34	n/a
Prototype prints	Material: PLA	n/a	n/a	Makerspace	n/a	3/20	n/a	n/a	\$4.92	n/a
Prototype print	Material: PLA	n/a	n/a	Makerspace	n/a	4/9	n/a	n/a	\$1.00	n/a
-										
-								TOTAL:	\$9.26	

Major team goals for the next week:

1. Complete all tests and analyze results.
2. Print final prototype for final presentation.
3. Begin work on final deliverables.

Next week's individual goals:

- Sara:
 - Help with 3-point bending test on Friday
 - Complete contamination testing early next week.
 - Analyze and organize results.
- Katherine:
 - Help conduct the 3-point bending test on Friday
 - Help conduct the contamination test and analyze the results
 - Have survey sent out to design curriculum and analyze results
- Cherry:
 -
- Adam:
 -

Timeline:

Task	Jan	Feb				March					April				May	
	26	2	9	16	23	1	8	15	22	29	5	12	19	26	3	10
Project R&D																
Background research	X	X	X	X	X	X	X									
Design development				X	X	X	X	X	X		X	X				
Prototyping						X			X		X	X				
Testings												X				
Deliverables																
Progress Reports		X	X	X	X	X	X	X	X		X	X				
PDS			X			X	X									
Prelim presentation/report						X	X									
Final Poster																
Meetings																
Client			X					X								
Advisor	X	X	X	X	X			X			X	X				
Website																
Update	X	X	X	X	X	X	X	X	X		X	X				

Previous week's goals and accomplishments:

- Goal: Print functional prototype for testing
 - This was achieved. An updated device for both the full length and shorter handle device were printed.
- Goal: Draft detailed protocols for testing and begin tests once the prototype is complete.
 - All protocols were drafted this week and testing will begin on Friday.

Activities:

Name	Date	Activity	Time (h)	Week Total (h)	Sem. Total (h)
Katherine	4/8	Generated an instruction manual for the use of the two proposed prototypes.	2	3.5	33
	4/9	Made slight modifications to the long prototype and 3D printed	0.5		
	4/9	Created a survey to be sent out to the BME design curriculum regarding the preferred prototype, the instructions of the device, and other aesthetic components of the design.	1		
Sara	4/7	Draft materials list for contamination testing and conduct background research on methods	1.5	3	29
	4/8	Draft protocol for contamination testing	1.5		
Cherry	4/7	Generated models in Solidworks to conduct a simulation	2	3.5	24.25
	4/8	Drafted protocol for tipping testing	1.5		
Adam					24