

Dynamic Balance Device

Date: 04/5/2026 - 04/11/2026

Client: Mr. Daniel Kutschera

Advisor: Professor Monica Ohnsorg

Team:

Kat Sattel - Team Leader (sattel@wisc.edu)

Therese Kalt- Communicator (tkalt@wisc.edu)

Noor Awad - BSAC (nawad2@wisc.edu)

Freyja Heggeland - BWIG/BPAG (heggeland@wisc.edu)

Problem statement: Patients that have suffered strokes have a 25-30% rate of developing spatial neglect syndrome. Symptoms of spatial neglect syndrome include loss of awareness of the body in space. Our client, Dr. Kutschera, a physical therapist, helps patients to regain strength and balance following a stroke. The client seeks to develop a device that can be used to improve visual scanning and balance training that is an update from the previous yard-stick design. The device should be mutli-functional so as to help patients with varying degrees of need and be effective in the rehabilitation treatment.

Brief status update: This week, all materials ordered had arrived and the team began final fabrication. The team also completed a draft of the executive summary for design awards.

Difficulties / advice requests: None to report

Current design:

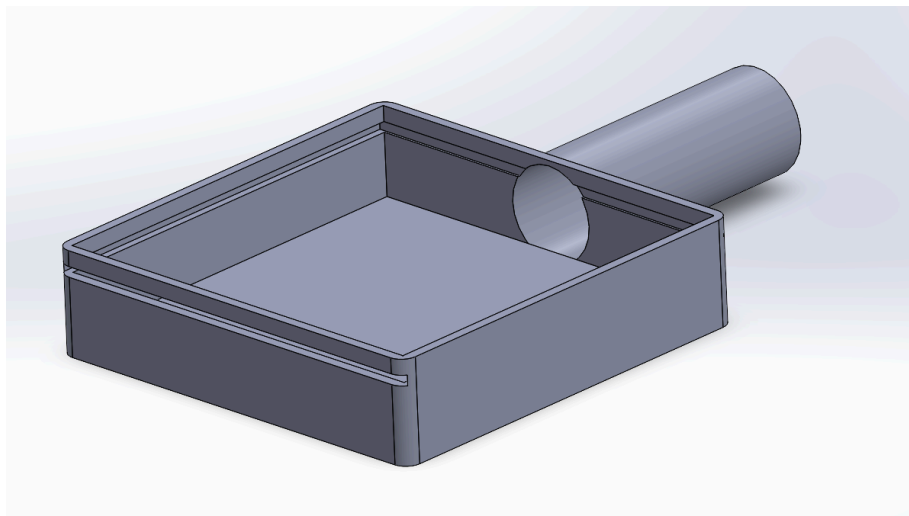

Figure 1: CAD Model of the Display Portion of the Design

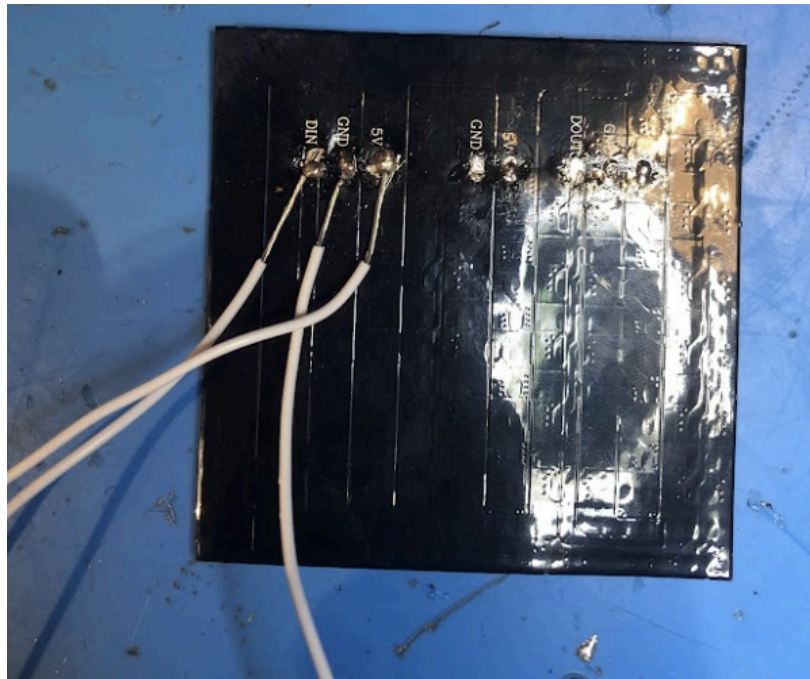

Figure 2: Backside of the LED Display with Soldered Wires.

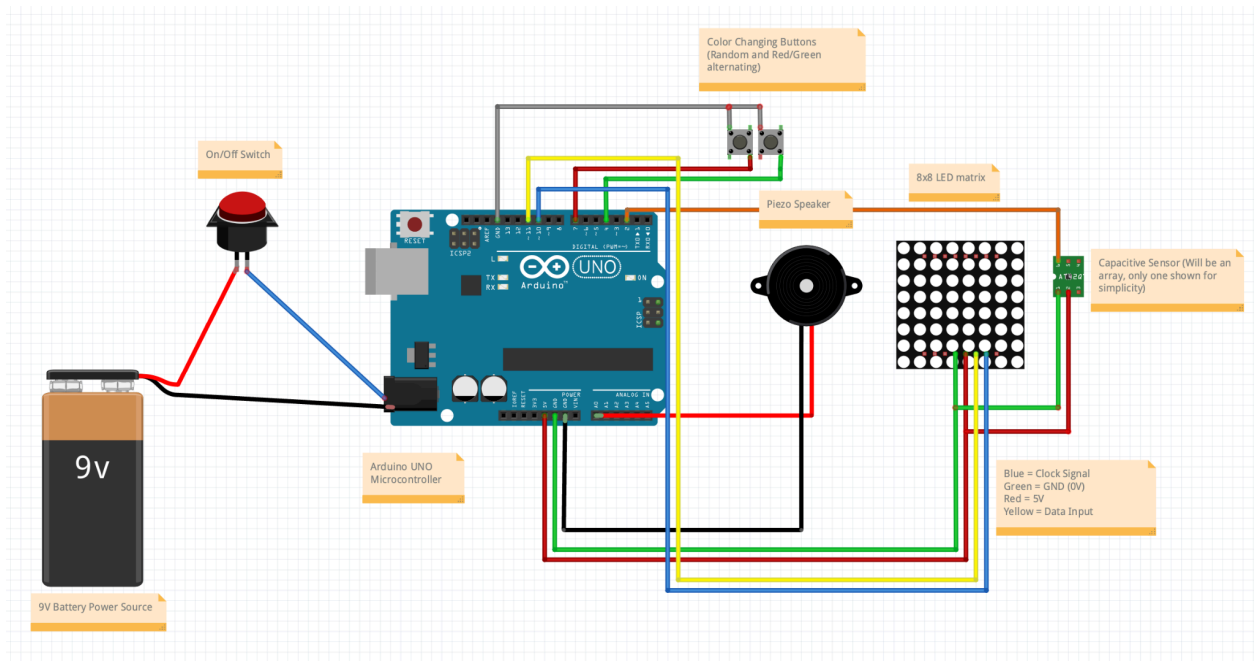

Figure 3: Fritzing Diagram of Circuitry for the Entire Device

Materials and expenses

See table below:

Item	Description	Manufacturer	Mft Pt#	Vendor	Vendor Cat#	Date	#	Cost Each	Total	Link
Materials										

Carbon Fiber Tube	1m long, 20mm outer diameter, 18mm inner diameter	CHZDPP	B0DJJ TX3S Q	Amazon	B0DJJT X3SQ	3/9/2026	1	\$48.49	\$48.49	Amazon.com	
3D Filament	3D Printed portion	Makerspace	n/a	Makerspace	n/a	3/18/2026	1	\$1.89	\$1.89	https://making.engr.wisc.edu/	
Metal rod	Metal rod	Makerspace	n/a	Makerspace	n/a	3/20/2026	1	\$0.00	\$0.00	https://making.engr.wisc.edu/	
arm band	arm band	All in Motion	197543111024	Target	082-02-2568	4/8/2026	1	\$11.66	\$11.66	https://target.com	
Super glue	Clear super glue	Gorilla	524277820380	Target	081-22-7899	4/8/2026	1	\$5.39	\$5.39	https://target.com	
Electronics											
Capacitive Touch Sensor Switch	Sensor	Arduino	TTP223B	Ebay	TTP223B	3/9/2026	1	\$8.32	\$8.32	Ebay.com	
9v battery	Battery	Vetco Electronics	VUPN8981	Shopify	VUPN8981	3/9/2026	1	\$0.75	\$0.75	Vetco Electronics	
Tactile switch	Button	Vetco Electronics	TEA-5144	Shopify	TEA-5144	3/9/2026	2	\$0.89	\$1.78	Vetco Electronics	
Waterproof Switch	On/Off switch	Vetco Electronics	NTE-54-250W	Shopify	NTE-54-250W	3/9/2026	1	\$9.99	\$9.99	Vetco Electronics	
Speaker Module	Speaker	Vetco Electronics	VUPN6344	Shopify	VUPN6344	3/9/2026	2	\$4.21	\$16.21	Vetco Electronics	
Arduino Nano	Microcontroller	Arduino	A000005	Amazon	A000005	3/25/2026	1	\$21.69	\$21.69		
									TOTAL:	\$126.17	

Major team goals for the next week

1. Complete fabrication
2. Begin testing

Next week's individual goals

- Kat Sattel
 - Machining with carbon fiber rod
 - Complete circuitry
 - Begin testing
- Therese Kalt
 - Fabricate entire design
 - Begin testing
- Noor Awad
 - Complete circuitry
 - Help team with testing
- Freyja Heggeland
 - Help team with testing protocol development
 - Machining with carbon fiber rod

Timeline

Task	Week				Week					Week				Week	
	1	2	3	4	5	6	7	8	9	10	11	12	13	14	15
Project R&D															
Empathize	X														
Background...	X	X	X	X	X	X									
Prototyping						X	X	X		X					
Testings															
Deliverables															
Progress Reports	X	X	X	X	X	X	X	X		X					
Prelim presentation				X											
Final Poster															
Meetings															
Client		X		X		X		X							
Advisor	X	X	X	X	X	X	X	X		X					
Website															
Update	X	X	X	X	X	X	X	X		X					

Filled boxes = projected timeline

X = task was worked on or completed

Previous week's goals and accomplishments

- Kat Sattel
 - Selected design award
 - Worked on executive summary
- Therese Kalt
 - Continued to update display portion of device
 - Purchased arm band for holding circuitry

- Noor Awad
 - Worked on executive summary
 - Researched how to use Arduino nano
- Freyja Heggeland
 - Worked on executive summary
 - Selected design award
 - Previewed new Arduino nano code

Activities

Name	Date	Activity	Time (h)	Week Total (h)	Sem. Total (h)
Kat Sattel	4/7/2026 4/9/2026	- Worked on executive summary - Design consultation at the Makerspace	2 0.5	2.5	34
Therese Kalt	4/7/2026	- Updated CAD - Purchased arm band for holding circuitry	1 0.5	1.5	31.5
Noor Awad	4/7/2026	- Worked on executive summary - Researched arduino nano	1 1	2	28
Freyja Heggeland	4/3/2026 4/6/2026 4/7/2026	- Worked on executive summary - Worked on executive summary - Finalized executive summary and developed survey protocols	1 1 1	3	37