

Dynamic Balance Device

Date: 04/12/2026 - 04/18/2026

Client: Mr. Daniel Kutschera

Advisor: Professor Monica Ohnsorg

Team:

Kat Sattel - Team Leader (sattel@wisc.edu)

Therese Kalt- Communicator (tkalt@wisc.edu)

Noor Awad - BSAC (nawad2@wisc.edu)

Freyja Heggeland - BWIG/BPAG (heggeland@wisc.edu)

Problem statement: Patients that have suffered strokes have a 25-30% rate of developing spatial neglect syndrome. Symptoms of spatial neglect syndrome include loss of awareness of the body in space. Our client, Dr. Kutschera, a physical therapist, helps patients to regain strength and balance following a stroke. The client seeks to develop a device that can be used to improve visual scanning and balance training that is an update from the previous yard-stick design. The device should be mutli-functional so as to help patients with varying degrees of need and be effective in the rehabilitation treatment.

Brief status update: This week, the team spent time fabricating the final prototype and completed all protocols. The team also created an outline for the final poster.

Difficulties / advice requests: None to report

Current design:

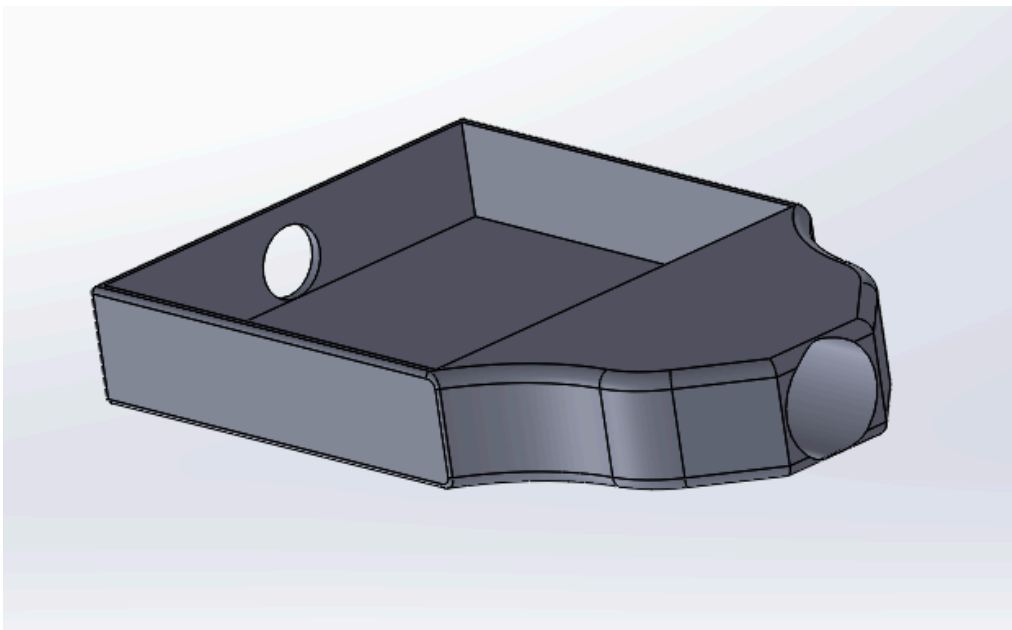

Figure 1: CAD model of the display portion of the design

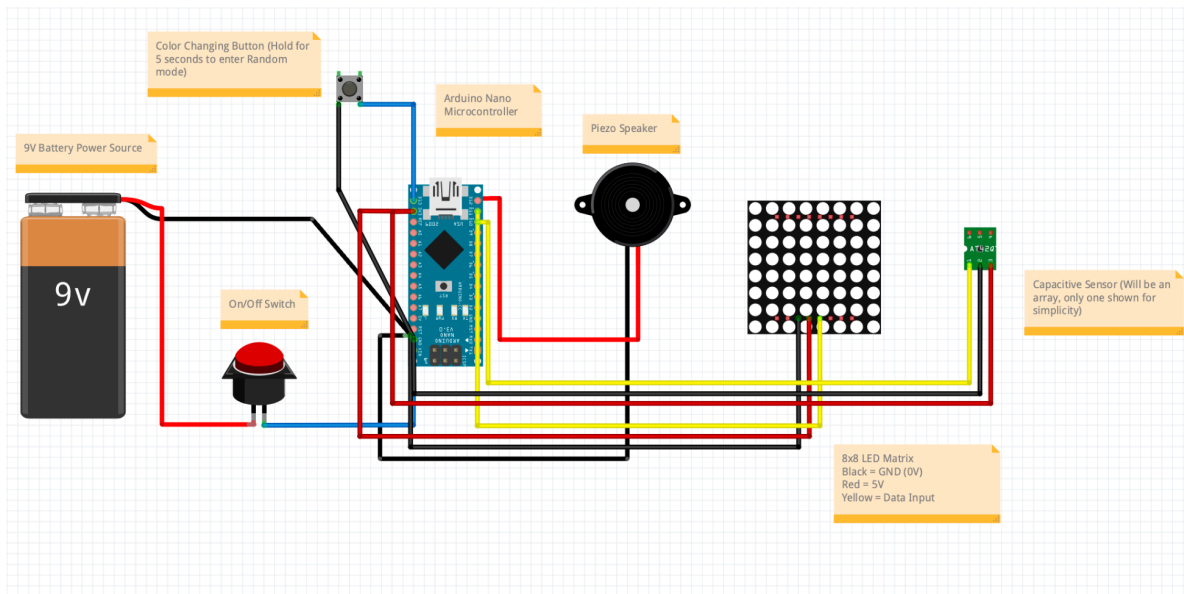

Figure 2: Fritzing diagram of final circuitry for the entire device

Materials and expenses

See table below:

Item	Description	Manufacturer	Mft Pt#	Vendor	Vendor Cat#	Date	#	Cost Each	Total	Link
Materials										
Carbon Fiber Tube	1m long, 20mm outer diameter, 18mm inner diameter	CHZDPP	B0DJ JTX3 SQ	Amazon	B0DJJT X3SQ	3/9/202 6	1	\$48.49	\$48.49	Amazon.com
3D Filament	3D Printed portion	Makerspace	n/a	Makerspace	n/a	3/18/20 26	1	\$4.50	\$4.50	https://making.engr.wisc.edu/
Metal rod	Metal rod	Makerspace	n/a	Makerspace	n/a	3/20/20 26	1	\$0.00	\$0.00	https://making.engr.wisc.edu/
arm band	arm band	All in Motion	19754 31110 24	Target	082-02- 2568	4/8/202 6	1	\$11.66	\$11.66	https://target.com
Super glue	Clear super glue	Gorilla	52427 78203 80	Target	081-22- 7899	4/8/202 6	1	\$5.39	\$5.39	https://target.com
Vinyl Sheet	Vinyl Sheet	Makerspace	n/a	makerspace	n/a	4/11/20 26	1	\$0.15	\$0.15	https://making.engr.wisc.edu

										du/
Vinyl Stickers	Inch markers	Shunyinlai	B0FLXM9H8C	Amazon	B0FLXM9H8C	4/12/2026	1	\$14.75	\$14.75	amazon.com
Electronics										
Capacitive Touch Sensor Switch	Sensor	Arduino	TTP223B	Ebay	TTP223B	3/9/2026	1	\$8.32	\$8.32	Ebay.com
9v battery	Battery	Vetco Electronics	VUPN8981	Shopify	VUPN8981	3/9/2026	1	\$0.75	\$0.75	Vetco Electronics
Tactile switch	Button	Vetco Electronics	TEA-5144	Shopify	TEA-5144	3/9/2026	2	\$0.89	\$1.78	Vetco Electronics
Waterproof Switch	On/Off switch	Vetco Electronics	NTE-54-250W	Shopify	NTE-54-250W	3/9/2026	1	\$9.99	\$9.99	Vetco Electronics
Speaker Module	Speaker	Vetco Electronics	VUPN6344	Shopify	VUPN6344	3/9/2026	2	\$4.21	\$16.21	Vetco Electronics
Arduino Nano	Microcontroller	Arduino	A000005	Amazon	A000005	3/25/2026	1	\$21.69	\$21.69	amazon.com
Braided Cable Sleeve	Cable Sleeve	Alex Tech	704256851316	Amazon	B071G5L29C	4/11/2026	1	\$7.99	\$7.99	amazon.com
									TOTAL:	\$151.67

Major team goals for the next week

1. Complete testing and analyze data
2. Create final executive summary
3. Present poster

Next week's individual goals

- Kat Sattel
 - Complete testing and poster
 - Present poster
- Therese Kalt
 - Complete testing
 - Complete poster
 - Present poster
- Noor Awad
 - Complete testing and poster
- Freyja Heggeland
 - Run testing protocols and collect/summarize data

- Complete and present team poster

Timeline

Task	Week				Week					Week				Week	
	1	2	3	4	5	6	7	8	9	10	11	12	13	14	15
Project R&D															
Empathize	X														
Background...	X	X	X	X	X	X									
Prototyping						X	X	X		X	X				
Testings											X				
Deliverables															
Progress Reports	X	X	X	X	X	X	X	X		X	X				
Prelim presentation				X											
Final Poster															
Meetings															
Client		X		X		X		X							
Advisor	X	X	X	X	X	X	X	X		X	X				
Website															
Update	X	X	X	X	X	X	X	X		X	X				

Filled boxes = projected timeline

X = task was worked on or completed

Previous week’s goals and accomplishments

- Kat Sattel
 - Began fabrication/finished all protocols
 - Completed draft of executive summary
 - Created SolidWorks model, 3D printed, and fabricated handle
 - Worked on connecting circuitry all together
 - Divided up final poster
- Therese Kalt
 - Created cricut template, cut it on paper, and used this template to paint the rod for the measurement system
 - Created an updated display portion of the design in SolidWorks with a cutout for the speaker
 - Created a new SolidWorks part that goes on top of the display and houses the sensors securely
 - Cut carbon fiber rod down to 31.5 in and drilled a hole for the wires to flow from the rod to the buttons in the handle
 - Divided final poster and report
 - Drilled additional holes in the carbon fiber for circuitry
- Noor Awad
 - Completed circuitry
 - Finished fabricating handle including drilling 2 holes

- Helped design new sensor housing
- Helped drill additional holes
- Freyja Heggeland
 - Wrote survey questions and organized survey creation
 - Worked with circuitry soldering
 - Finalized executive summary using advisor feedback
 - Divided up final poster

Activities

Name	Date	Activity	Time (h)	Week Total (h)	Sem. Total (h)
Kat Sattel	4/11/2026	- Finished protocols, began soldering, various fabrication	5.5	15.5	49.5
	4/13/2026	- Finalized Arduino code	1		
	4/14/2026	- Continued soldering; assembly	4		
	4/15/2026	- Soldering, cont'd. Handling machining	5		
Therese Kalt	4/11/2026	- Divided final poster and report, created new display part in SolidWorks, created the template and cutout for the measurement system	5.5	12.5	44
	4/13/2026	- Cut and drilled hole for rod, taped cutout to the rod and painted the tick marks, checked on print and moved it to a different printer	3		
	4/15/2026	- Created new SolidWorks part to house the sensors	1.5		
	4/16/2026	- Drilled additional holes in rod and printed the new SolidWorks part	1.5		
Noor Awad	4/14-4/16	- Completed circuitry	7	10.5	38.5
		- Finished fabricating handle including drilling 2 holes	2		
	4/14/26	- Helped design new sensor housing	.5		
	4/15/26	- Helped drill additional holes	1		
Freyja Heggeland	4/11/2026	- Finished protocols and began soldering	5.5	7	44.5

BME Design: 200, 300, 301, 400 and 402

	4/13/2026	- Updated executive summary	1		
	4/15/2026	- Finished executive summary	1		